



**MITSUBISHI
ELECTRIC**

MOLDED-CASE CIRCUIT BREAKERS
EARTH-LEAKAGE CIRCUIT BREAKERS

Changes for the Better

World Super
WS
Series



**Empowering
Industries**

09
A

INDEX

This material has been prepared for those who use the products for manufacturing assemblies, for holding electric works, for holding maintenance and for the others acquainted with electric expertise including those who operate the products (final users).

Introduction	1
Features	3
The Great Variable Accessories for Perfect Solution (Product Skeleton)	9

1. Series Configuration and List of Product Models	11
---	-----------

2. Detailed Specifications	13
Molded-Case Circuit Breakers	13
Earth-Leakage Circuit Breakers	21
Earth-Leakage Circuit Breakers for CE Marking	25
Motor-Protection Breakers	29
UL Listed Products	30
Miniature Circuit Breakers	31
ELRs and ZCTs	35
Circuit Protectors	37

3. Special-purpose Breakers	38
Mag Only (Instantaneous tripping circuit breakers)	38
DC MCCBs and DSN Switches	38
400Hz MCCBs	39
Low-Instantaneous MCCBs	39
Generator-Protection MCCBs	39
Measuring Display Unit (MDU) Breakers	40

4. Connection Method	46
1. Connection Types	46
2. Connection Accessories	46
3. Connection of Line and Load	46

Caution

The manual covers the product specifications for selecting an appropriate low-voltage breaker. There is the "HANDLING AND MAINTENANCE" describing how to handle the products. To use the products, separately request the "HANDLING AND MAINTENANCE", for correct operation.

1

2

3

4

5

6

7

8

9

5. Accessories 47**Internal Accessories 47**

1. Accessories	47
2. Switch Operation and Rating	47
3. Maximum Number of Internally Mounted Accessories	48
4. Shunt Trip (SHT)	55
5. Undervoltage Trip (UVT)	55
6. Test Button Module (TBM)	56
7. Lead-wire Specifications	56
8. Internal Terminal (INT)	56
9. Vertical Lead-wire Terminal Block (SLT)	57
10. Pre-Alarm Module (PAL)	58
11. 3ø4W Neutral-pole protection Relay (NR)	59

External Accessories 60

1. F-type Operating Handle (Breaker Mount Type)	60
2. V-type Operating Handle (Door Mount Type)	63
3. S-type Operating Handle	68
4. Terminal Cover	70
5. Electrical Operation Device	71
6. Mechanical Interlocks (MI)	79
7. Handle Lock Devices and Card Holder	80
8. IEC 35mm Rail Mounting Adapters	80

6. Characteristics and Dimensions 81

Molded-Case Circuit Breakers and Motor Breakers	81
Earth-Leakage Circuit Breakers	117
Earth-Leakage Circuit Breakers for CE Marking	141
UL 489 Listed Molded-Case Circuit Breakers	161
Miniature Circuit Breakers	173
DIN Series	177
Circuit Protectors	181

7. Ordering Information 183

Molded-Case Circuit Breakers	183
Earth-Leakage Circuit Breakers	183

8. Melshort 2 184

(A Smarter, Easier Way to Select Breakers)

9. Low-voltage switchgear Technical information service via the internet 185

(<http://www.MitsubishiElectric.co.jp/haisei/lvs/>)

Full range of MITS (30A to 16

High-Performance

Downsizing of 630AF, New Digital ETR

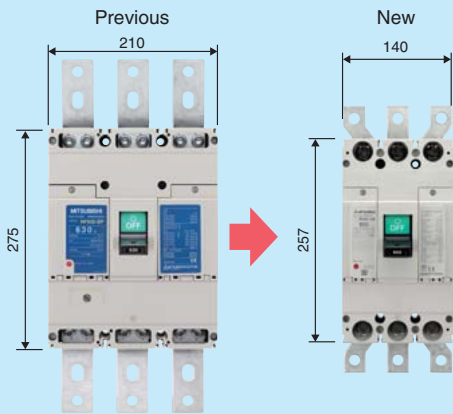

Volume 60% downsized

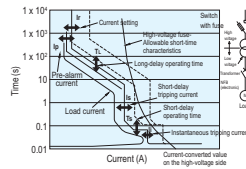

New Digital ETR

Glo

Compliance with w

MITSUBISHI World Super Series

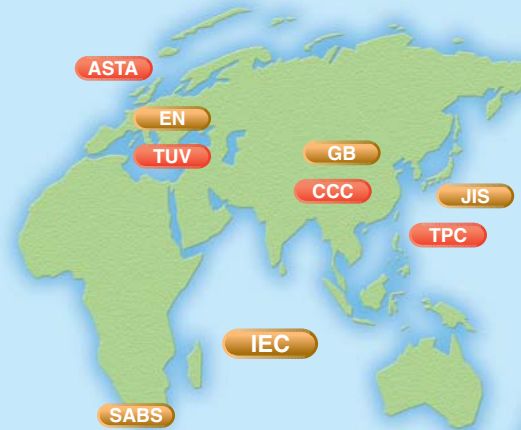

Best Solution

Plenty of accessories, Easy installation

250AF (Type "SGW, HGW, RGW, UGW") Product Skelton

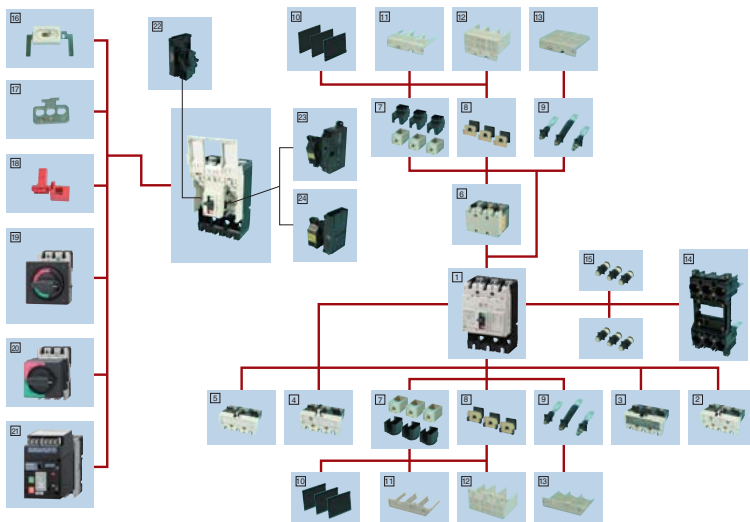

World Super
W/S
Series

UBISHI WS Series (00A frame)

bal

worldwide standards

Designed for Global Application



Reliable

High reliability, Best performance

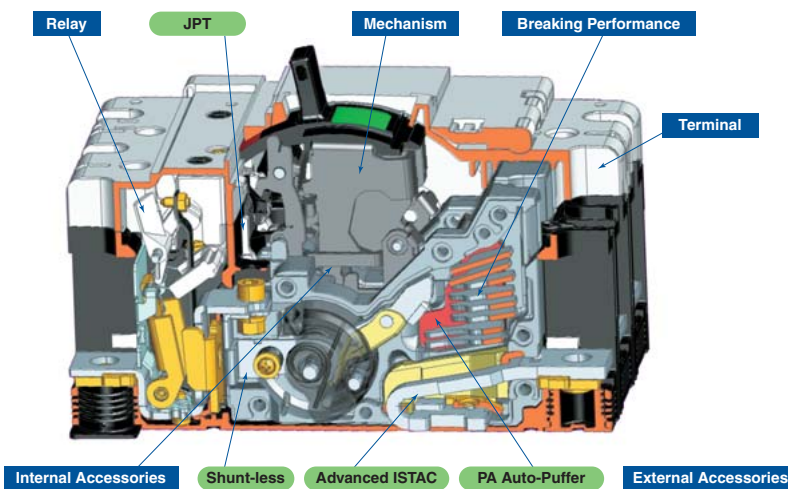

Intelligent

Measuring and communicating

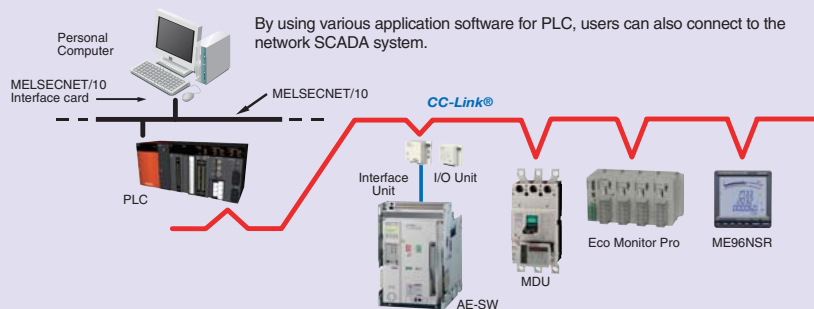

MITSUBISHI World Super Series Designed for Global Application

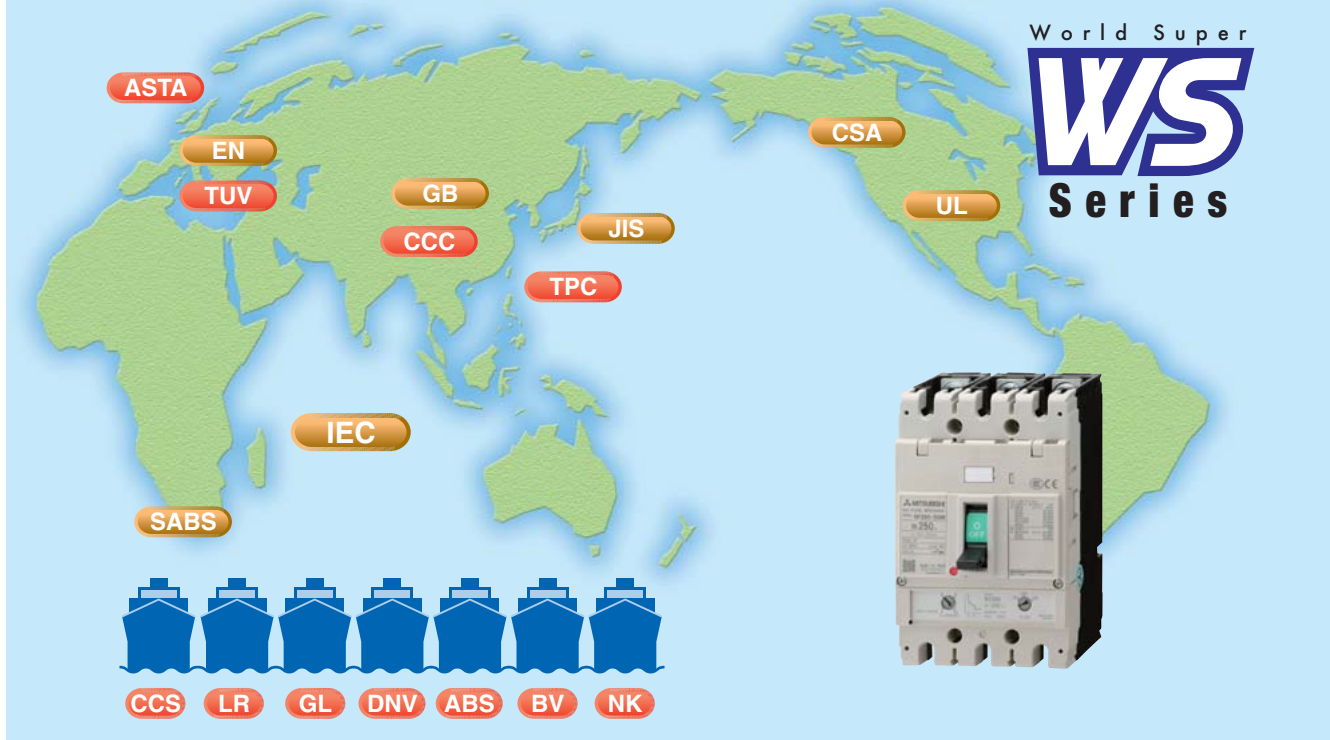

WS Series International Standard Conformance List

Standards	IEC	JIS	EN	GB	Safety Certification		Marine Approvals						
	International	Japan	Europe	China	USA	Canada	UK	Germany	Norway	USA	France	Japan	China

- Compliance with worldwide standards (IEC/JIS/EN/GB/UL/CSA)
- Applicable to marine approvals
- New design with Laser Marking
- All products with Isolation function
- RoHS compliance

* RoHS...The Restriction of the use of certain Hazardous Substances in Electrical and Electronic Equipment



NF250-SGW 3P

Full range of WS Series (up to 1600AF)

	AF	32(30)	63	125	160	250	400	630	800	1000	1250	1600
MCCB	NF-C	NF30-CS	NF63-CW	NF125-CW		NF250-CW	NF400-CW	NF630-CW	NF800-CEW			
	NF-S	NF32-SW	NF63-SW	NF125-SW	NF160-SW	NF250-SW	NF400-SW	NF630-SW	NF800-SEW	NF1000-SEW	NF1250-SEW	NF1600-SEW
				NF125-SGW	NF160-SGW	NF250-SGW	NF400-SGW	NF630-SGW	NF800-SDW			
	NF-H		NF63-HW	NF125-HW	NF160-HW	NF250-HW	NF400-HEW	NF630-HEW	NF800-HEW			
	NF-U			NF125-HGW	NF160-HGW	NF250-HGW	NF400-REW	NF630-REW	NF800-REW			
ELCB	NV-C	NV30-CS	NV63-CW	NV125-CW		NV250-CW	NV400-CW	NV630-CW	NV800-CEW			
	NV-S	NV32-SW	NV63-SW	NV125-SW		NV250-SW	NV400-SW	NV630-SW	NV800-SEW			
				NV125-SGW		NV250-SGW	NV400-SGW	NV630-SGW	NV800-SDW			
	NV-H		NV63-HW	NV125-HW		NV250-HW	NV400-HEW	NV630-HEW	NV800-HEW			
	NV-U			NV125-RW		NV250-HEW	NV400-REW					

400AF, 630AF & 800AF models easier to use

- 630AF models downsized to the size of 400AF model, contributing to compact panels and simplification of design.
- MCCB-AC/DC common use (excl. Electronic trip type)
3-pole: available up to 400VDC, 4-pole: available up to 500VDC (NF400-SW, NF630-SW)
- Improved breaking capacity at 690VAC (NF400-HEW, NF630-HEW)

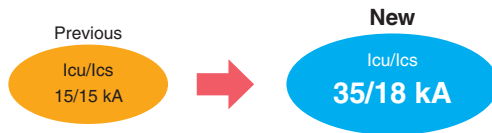

- Improved breaking capacity at 400/415VAC (NF400-SEW, NF630-SW/SEW, NF800-SEW)

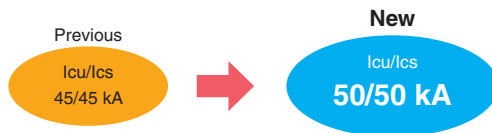

NEW Digital ETR (Electronic Trip Relay) for NF1000-SEW, NF1250-SEW & NF1600-SEW

- Installed digital ETR same as Electronic relay for under 800AF
 - Multi adjustment available (Long time delay, short time delay, Instantaneous, pre-alarm characteristics): easier coordination with upper breakers.
 - Pre-alarm equipped as Standard: LED turned on when load current exceeds pre-alarm setting current.
 - Suitable for use as a main breaker: isolation conformity to IEC Standard.

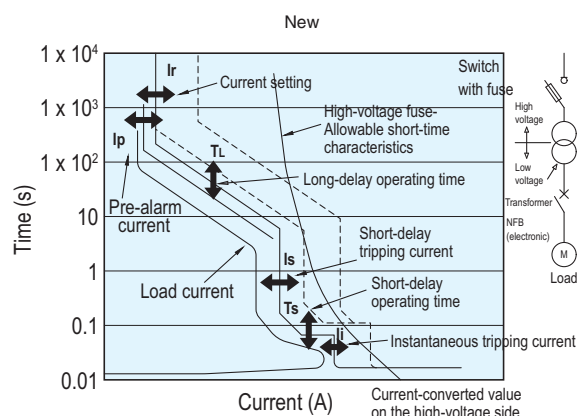
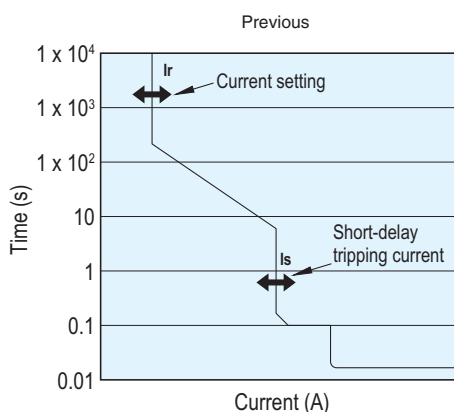
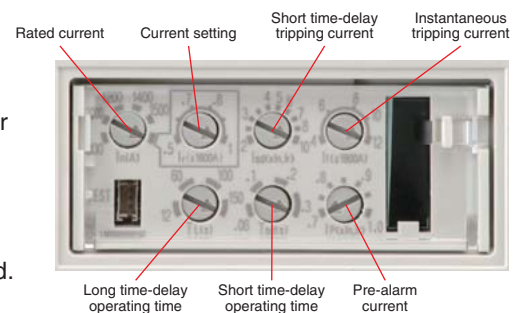

Technology for WS Series

Relay

- Relay-unit Thermal type & Electronic type
- AC/DC common use
- Thermal adjustable range is expanded.

Mechanism

- Isolation suitability
- Class II insulation
- Increased operating cycles

Breaking Performance

- Increased Icu
- High voltage
- Ics=100% Icu

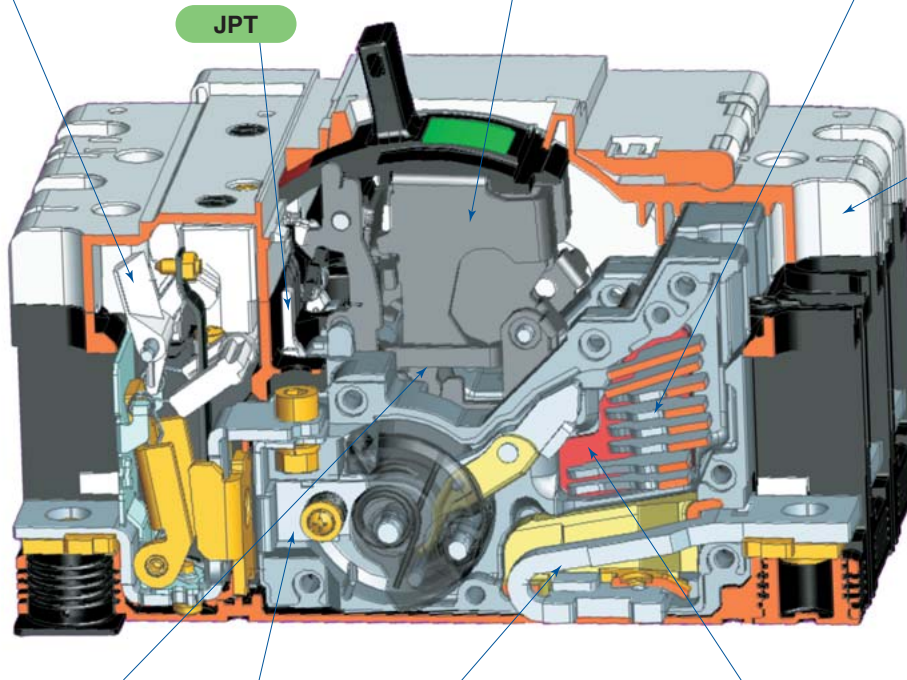

Terminal

- IP20 Mold-cover Finger protection
- Front compression terminal ↔ Box terminal ↔ Rear ↔ PM

Internal Accessories

- Cassette-type accessories
- Wide range of Rated Voltage

Shunt-less

Advanced ISTAC

PA Auto-Puffer

External Accessories

- Electric operators
 - ① High speed type
 - ② Isolation suitability
- IP20 PM with Safety Device
- Handle Lock Device
- F/V handle
- IP40 Terminal cover

[PA Auto-Puffer]

Polymer Ablation type Auto-Puffer [Adopted on SGW, HGW, RGW, UGW]

[JPT]

Jet Pressure Trip Mechanism [Adopted on SGW, HGW, RGW, UGW]

[Advanced ISTAC]

Advanced Impulsive Slot-Type Accelerator [Adopted on SGW, HGW, RGW, UGW]

[Shunt-less]

Shunt-less Current Flow Technology [Adopted on SGW, HGW, RGW, UGW]

Double plates conductors hold the movable conductor without flexible wires. This shunt-less structure achieves the increased operating cycles.

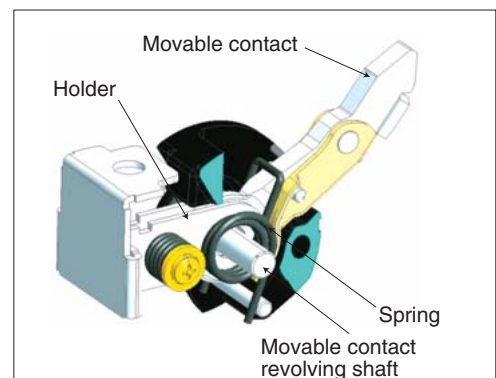
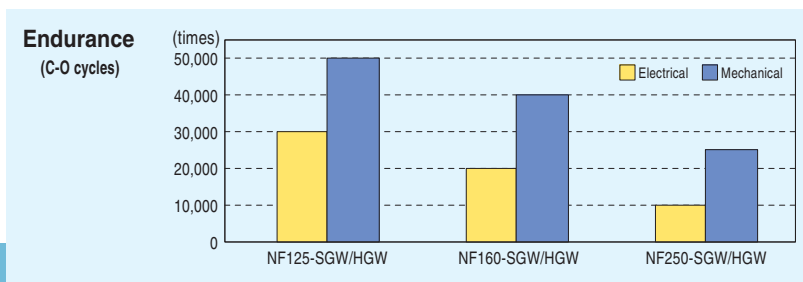

During revolution the movable contact is constantly in contact with the holder, maintaining current flow.

■ Best performance of SGW / HGW / RGW / UGW

Breaking Capacity Icu/Ics

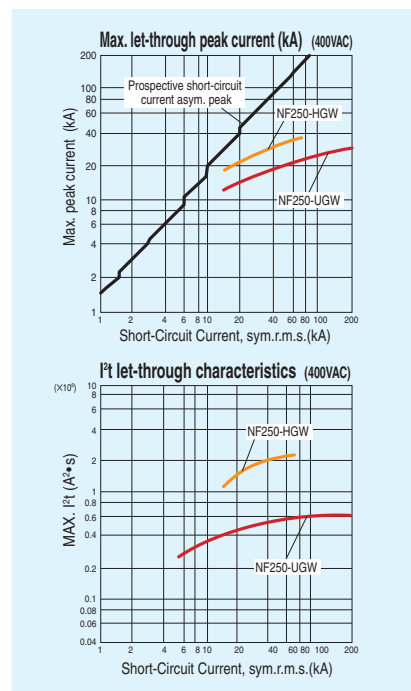
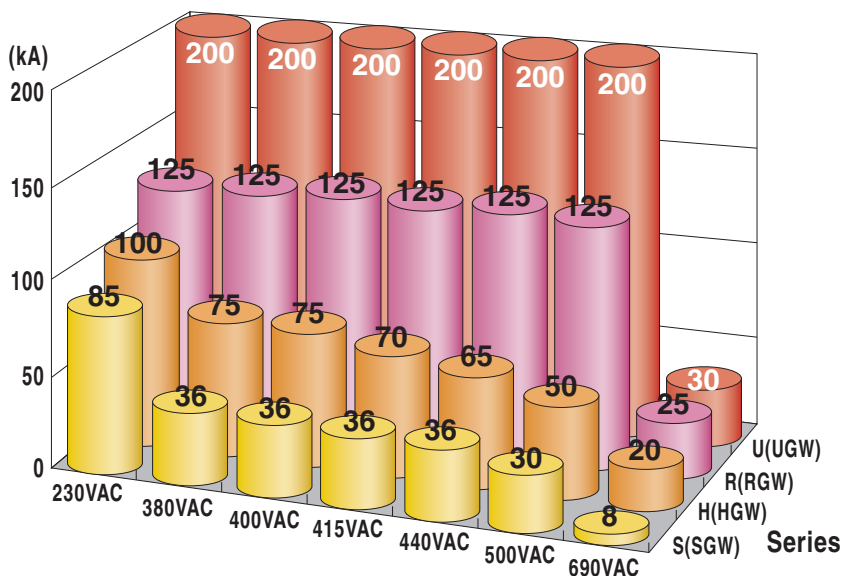

■ 2 types of Relay for SGW / HGW / RGW / UGW

Thermal Adjustable Relay

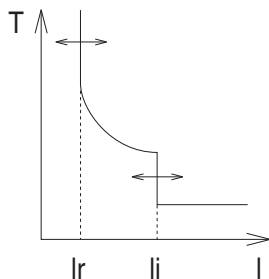
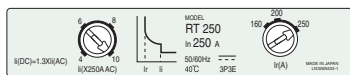

Rating	In(A)	25	40	63	100	125	160	250
Type	NF250-SGW/HGW						●	●
	NF160-SGW/HGW						●	
	NF125-SGW/HGW	●	●	●	●	●		
		Hi						
		Lo						

		Overload Protection (Thermal)						
Tripping threshold Ir (A)		16-25	25-40	40-63	63-100	80-125	125-160	160-250
Neutral protection (*1)	4P3E	No Protection						
	4P4E	1 × Ir						



Thermal type unit

		Short-Circuit Protection (Magnetic)	
Tripping threshold Ii		Fixed	Adjustable
		10×In (AC), 13×In (DC)	4 to 10×In (AC), 5.2 to 13×In (DC)

Note (*1) The type 4P3E is standard. If the type 4P4E is required, specify the type 4P4E separately and explicitly.

Electronic Relay

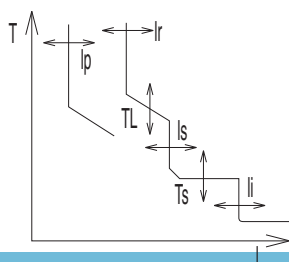
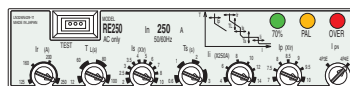

Rating	In(A) (40C)	32	63	100	125	160	250
Type	NF250-SGW/HGW						●
	NF160-SGW/HGW						●
	NF125-SGW/HGW	●	●	●	●	●	
		Hi					
		Lo					

		Overload Protection					
Tripping threshold Ir (A)		16-32	32-63	63-100	75-125	80-160	125-250
LTD	Tripping time TL(s)	12-60-80-100 step adjustable (at 2 × Ir)					
	Neutral protection (Selectable)	0-1 × Ir (Step adjustable)					



Electronic type unit

		Short-Circuit Protection	
STD	Pickup current Is	2-2.5-3-3.5-4-5-6-7-8-10 × Ir step adjustable	
	Tripping time Ts(s)	0.06-0.1-0.2-0.3 step adjustable (at 1.5 × Is)	
INST	Tripping threshold Ii	4 to 14 × In continuous adjustable	

		Pre-Alarm (for Indication)	
PAL	Pickup current Ip	0.7-0.75-0.8-0.85-0.9-0.95-1.0 × Ir step adjustable	
	Operating time Tp	TL/2	

		Indicator (LED)	
	70%-LED (green)	Lights at 0.7 × Ir	
	PAL-LED (orange)	Flashes at Ip and Lights at over Tp	
	Over-LED (red)	Lights at 1.15 × Ir	

Internal Accessories

The adoption of cassette-type internal accessories simplifies use, and the common use of different voltages realizes a major reduction in the number of types. Additionally, UVTs are now available for ELCBs and time delay types have been expanded, offering a wider range of applications.

	Previous models	WS Series (New)
SHT voltage	VAC (24), (48), 100-120, 200-240, 380-450, (440-550)	24-48, 100-240, 380-550
	VDC (12), (24), (36), (48), 100, (110), (125), (220)	12, 24-36, 36-48, 100-125, 220-250
UVT voltage	VAC 100-110, (100-120), 200-220, (220-240), (380-415), 400-440, (440-480), (500-550)	24/48, 100-110/120-130, 200-220/230-250, 380-415/440-480, 500-550/690
	VDC (24), (48), 100, (110)	24/48, 100/110, 110/125

3-way Lead Wire (adjustable)



Vertical lead wire terminal block (SHT)



Lead wire to line side

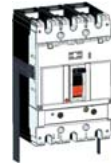

Flying lead wire

* Cassette-type Accessories

Giving greater flexibility when upgrading circuits, cassette-type accessories make ordering easy and enable simple, one-touch installation. Insulation also improves safety.

Compatible with all breaker series

The alarm switch (AL), auxiliary switch (AX), shunt trip (SHT), and undervoltage trip (UVT) all come as cassette-type accessories compatible with all breaker series.



1. Push the trip button (PTT)



2. Loosen the front cover screws



3. Open the front cover



4. Install the accessories



5. Close the front cover and tighten the screws.

External Accessories

High-speed Motor Device

Motor devices for 125-250AF are now easier to use, contributing to simple installation.

- * A spring charge mechanism has been adopted for high-speed operation. (0.05~0.1sec)
- * Installation is fast and simple, only requiring two screws.

External Handle

A safer and easy-to-operate handle has been adopted.

- * Complies with IP65 protection rating standards.
- * Isolation function achieved through combination with the breaker unit.
- * Structured to allow relay adjustments after installation as well.
- * Equipped with a cylinder key (optional) to prevent misuse.

IP-20PM with Safety Device [Adopted for SGW, HGW]

Specialized for 3- and 4-pole use (incompatible with 2-pole use).

- * Complies with IP-20 protection rating standards.
 - * A safety device is optional.
 - * Connectable with up to nine leads (for PLT).
 - * Can be modified from front to rear connection.
- (Note: Modification by users is not authorized)
IP20: Finger protection.

Power Supply Module

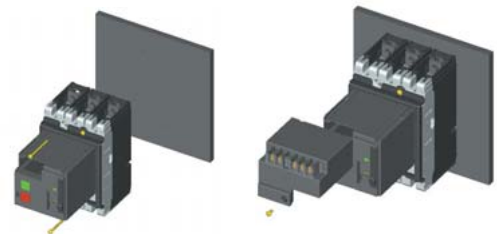

V-Handle

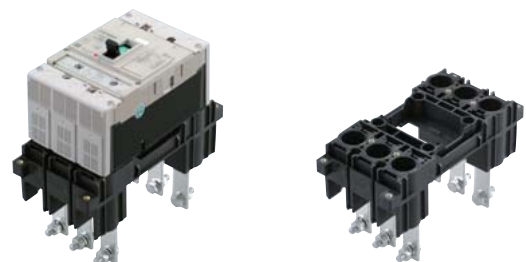

(IP-20PM)

Product Design Simplifies Use & Expands Applications

IP20 Terminal Connection

Safety of connections has been increased for SGW and HGW.

* Protection rating of IP20 as standard is ensured.



Terminal Cover

Major improvements have been achieved in front connection terminal safety.

* With terminal covers, a protection rating of IP40 is ensured. ("SGW, HGW, RGW, UGW")

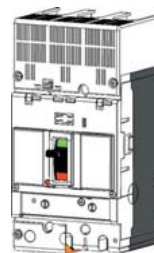

Connection Flexibility

Compatible with various connection methods. Solderless terminals are now built into the breaker design the conventional style where terminals are affixed on the outside.

Maximum connecting cable size of 185mm² (SGW/HGW). (Note: Certain models have externally attached terminals.)

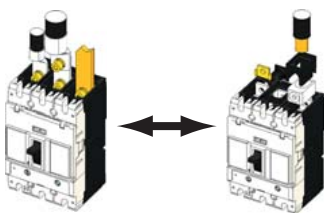

IEC Rail Mounting for 32, 63AF

Installation hooks are included for 32,63AF, markedly simplifying installation work.



Handle Locks

With the WS Series, ON/OFF locking is possible with the use of a padlock.

Up to three padlocks may be attached.

* Customers are requested to use their own padlocks.



ON lock

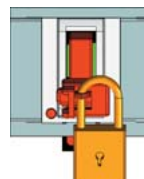

OFF lock

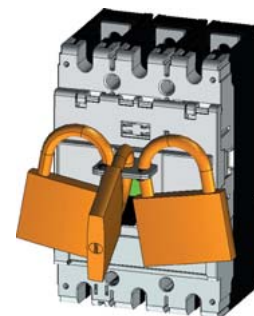

OFF lock with 3 padlocks ("SGW, HGW, RGW, UGW")

Intelligent

Measuring and Communicating

- MDU (Measuring Display Unit) with NF 250-800AF
- Compact, white measuring unit
- Measuring data can be transmitted to a PC or a PLC through **CC-Link**
- AL / AX with **CC-Link** transmission
- Improved accuracy(electric current): $\pm 2.5\%$ of rated value $\rightarrow \pm 2.5\%$ of true value

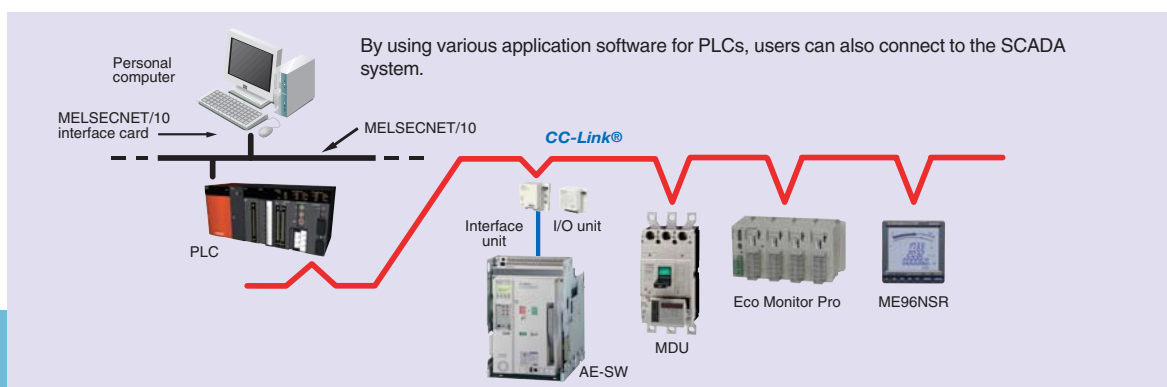

Product Skeleton

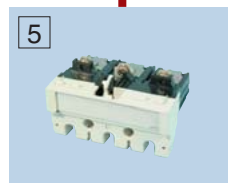
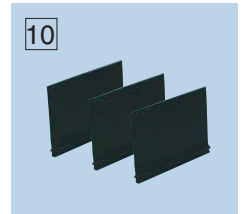
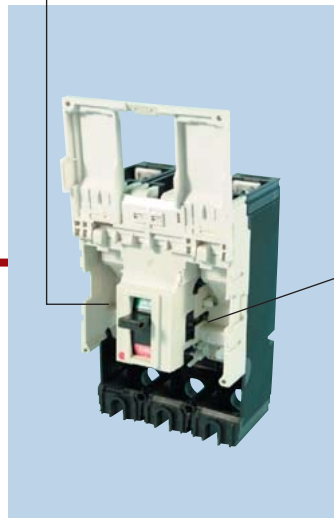
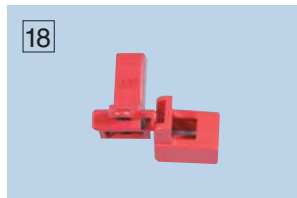
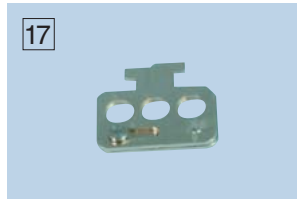
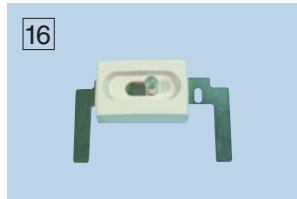

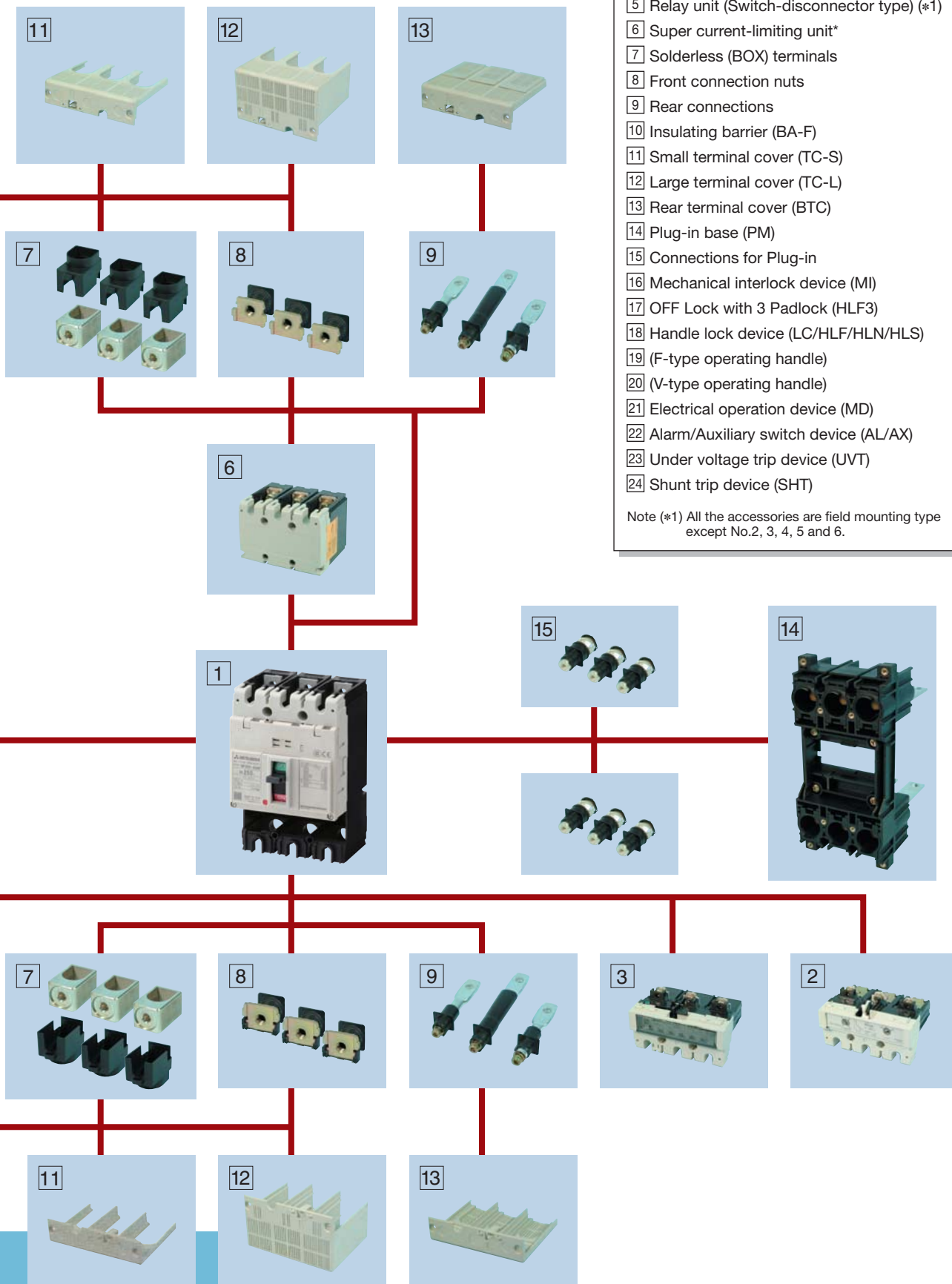









- 1 MCCB
- 2 Relay unit (Thermal type) (RT) (*1)
- 3 Relay unit (Electronic type) (RE) (*1)
- 4 Relay unit (Magnetic only type) (RM) (*1)
- 5 Relay unit (Switch-disconnector type) (*1)
- 6 Super current-limiting unit*
- 7 Solderless (BOX) terminals
- 8 Front connection nuts
- 9 Rear connections
- 10 Insulating barrier (BA-F)
- 11 Small terminal cover (TC-S)
- 12 Large terminal cover (TC-L)
- 13 Rear terminal cover (BTC)
- 14 Plug-in base (PM)
- 15 Connections for Plug-in
- 16 Mechanical interlock device (MI)
- 17 OFF Lock with 3 Padlock (HLF3)
- 18 Handle lock device (LC/HLF/HLN/HLS)
- 19 (F-type operating handle)
- 20 (V-type operating handle)
- 21 Electrical operation device (MD)
- 22 Alarm/Auxiliary switch device (AL/AX)
- 23 Under voltage trip device (UVT)
- 24 Shunt trip device (SHT)

Note (*1) All the accessories are field mounting type except No.2, 3, 4, 5 and 6.



1. Series Configuration and List of Product Models









Series Configuration

Molded-case circuit breakers			
NF-C Economy type	NF-S Standard type	NF-H High-performance type	NF-U Current limiting-type ultra breaker
			

Earth-leakage circuit breakers			
NV-C Economy type	NV-S Standard type	NV-H High-performance type	NV-U Ultra current-limiting type
			



Motor-protection breakers
<p>MB Motor breaker</p> 

Circuit protectors		
CP30-BA	CP-B	CP-S
For equipment		
		

Miniature circuit breakers								
BH	BH-P	BH-S	BH-PS	BH-D6	BH-DN	BV-D	BV-DN	KB-D
NEMA-type for consumer unit				DIN-series for general consumer unit				
								

List of Product Models

Series	Frame A	32 (30)	63	125 (100)	160	250	400	630	800	1000	1250	1600
Molded-case circuit breakers	NF-C Economy type	NF30-CS	NF63-CW	NF125-CW		NF250-CW	NF400-CW	NF630-CW	NF800-CEW			
	NF-S Standard type	NF32-SW	NF63-SW	NF125-SW	NF160-SW	NF250-SW	NF400-SW	NF630-SW	NF800-SDW	NF1000-SEW	NF1250-SEW	NF1600-SEW
				NF125-SGW	NF160-SGW	NF250-SGW	NF400-SW	NF630-SEW	NF800-SEW		NF1250-SDW	NF1600-SDW
	NF-H High-performance type	NF63-HW	NF125-HW	NF160-HW	NF250-HW	NF400-HW	NF630-HEW	NF800-HEW				
									NF125-HGW	NF160-HGW	NF250-HGW	NF400-REW
NF-U Ultra current-limiting type				NF125-RGW		NF250-RGW	NF400-UEW		NF800-UEW			
				NF125-UGW		NF250-UGW						
Earth-leakage circuit breakers	NV-C Economy type	NV30-CS	NV63-CW	NV125-CW		NV250-CW	NV400-CW	NV630-CW				
	NV-S Standard type	NV32-SW	NV63-SW	NV125-SW		NV250-SW	NV400-SW	NV630-SW	NV800-SEW			
						NV250-SEW	NV400-SEW	NV630-SEW				
	NV-H High-performance type	NV63-HW	NV125-HW			NV250-HW	NV400-HEW	NV630-HEW	NV800-HEW			
					NV250-HEW	NV400-REW						
NV-U Ultra current-limiting type			NV125-RW		NV250-RW							
Earth-leakage circuit breakers for CE Marking	NV-C Economy type		NV63-CW	NV125-CW		NV250-CW	NV400-CW	NV630-CW				
	NV-S Standard type	NV32-SW	NV63-SW	NV125-SW		NV250-SW	NV400-SW	NV630-SW	NV800-SEW			
						NV400-SEW	NV630-SEW					
	NV-H High-performance type	NV63-HW	NV125-HW			NV250-HW	NV400-HEW	NV630-HEW	NV800-HEW			
					NV400-REW							
NV-U Ultra current-limiting type			NV125-RW		NV250-RW							
Microprotection breakers	MB Motor breaker	MB30-CS	MB50-CW	MB100-SW		MB225-SW						
		MB30-SW	MB50-SW									

UL listed products	
NF-UL UL489 Listed Molded-case circuit breaker	NV-UL Earth-leakage protector UL489 Listed Molded-case circuit breaker
	
	(Details will be available upon request.)

Series	Frame A	50	100	150	225	250	400	600
UL listed products	UL489 Listed Molded-case circuit breaker	NF50-SWU	NF100-CWU NF100-SWU	NF-SFW	NF225-CWU	NF-SJW NF-HJW	NF-SKW	NF-SLW
	Earth-leakage protector UL489 Listed Molded-case circuit breaker (Details will be available upon request.)	NV50-SWU	NV100-SWU		NV225-CWU		NV-SKW	

Miniature Circuit Breakers

AF	60	100
BH	BH	
	BH-P	
	BH-S	—
	BH-PS	—

DIN Series

AF	63 and less
MCB	BH-D6
	BH-DN
RCCB	BV-D
RCBO	BV-DN
Isolating switch	KB-D

Circuit Protectors

AF	30 and less
CP	CP30-BA
	CP-B
	CP-S

2. Detailed Specifications

Molded-Case Circuit Breakers

Series	C Series	S Series	C Series	S Series	H Series	C Series			
Frame Size	30	32	63	63	63	125			
Image									
Type name	NF30-CS	NF32-SW	NF63-CW	NF63-SW	NF63-HW	NF125-CW			
Rated current in (Amp.)	3 5 10 15 20 30	3 4 (5) 6 10 (15) 16 20 25 (30) 32	3 4 (5) 6 10 (15) 16 20 25 (30) 32 40 50 (60) 63	3 4 (5) 6 10 (15) 16 20 25 (30) 32 40 50 (60) 63	10 (15) 16 20 25 (30) 32 40 50 (60) 63	50 (60) 63 (75) 80 100 125			
Rated ambient temperature (°C)	40	40	40	40	40	40			
Number of poles	2 3	2 3	2 3	2 3 4	2 3 4	2 3			
Rated insulation voltage Ui (V)	500	600	600	600	690	600			
Rated short-circuit breaking capacities (kA)	IEC 60947-2 (Icu/Ics)	AC (50/60Hz)	690V	-	-	-	2.5/1	-	
			525V	-	-	-	-	-	
			500V	-	2.5/1	2.5/1	7.5/4	7.5/4	7.5/4
			440V	-	2.5/1	2.5/1	7.5/4	10/5	10/5
			415V	1.5/1.5	2.5/1	2.5/1	7.5/4	10/5	10/5
			400V	1.5/1.5	5/2	5/2	7.5/4	10/5	10/5
			380V	1.5/1.5	5/2	5/2	7.5/4	10/5	10/5
			230V	2.5/2 (240V)	7.5/4	7.5/4	15/8	25/13	30/15
			DC	250V	2.5/1 (*4)	2.5/1 (*4)	7.5/4 (*4)	7.5/4 (*4)	7.5/4 (*1)
			300V	-	-	-	-	-	-
Suitability for isolation	-	●	●	●	●	●			
Utilization category	A	A	A	A	A	A			
Reverse connection (terminals unmarked)	-	●	●	●	●	●			
Rated impulse withstand voltage Uimp (kV)	4	6	6	6	6	8			
Pollution degree	2	2	2	2	2	3			
Number of operating cycles	without current	440V-In/2	10,000	10,000	10,000	15,000	15,000	10,000	
		440V-In	6,000 (415V)	6,000	6,000	15,000	15,000	6,000	
		690V-In/2	-	-	-	-	-	-	
		690V-In	-	-	-	-	-	-	
Overall dimensions (mm)	with current	440V-In/2	6,000 (415V)	6,000	6,000	8,000	8,000	6,000	
		440V-In	-	-	-	-	-	-	
		690V-In/2	-	-	-	-	-	-	
		690V-In	-	-	-	-	-	-	
Overall dimensions (mm)		a	45 67.5	50 75	50 75	50 75 100	50 75 100	60 90	
		b	96	130	130	130	130	130	
		c	52	68	68	68	68	68	
		ca	67	90	90	90	90	90	
Mass of front-face type (kg)	0.25 0.35	0.4 0.55	0.45 0.6	0.45 0.6 0.7	0.45 0.6 0.7	0.65 0.9			
Installation and connections	Fixed	Front	Screw terminal	●	●	●	●	●	
		Solderless (box) terminal (SL)	-	-	-	-	-	-	
		Busbar terminal	-	-	-	-	-	-	
		Rear	(B)	●	●	●	●	●	
		(PM)	-	-	-	-	-	-	
Plug-in	Rear/front IP20	(PM-IP)	-	-	-	-	-		
	IEC 35mm rail	Mounting hook (option)	●	●	●	●	●		
	Adapter (option)	-	-	-	-	-	-		
Cassette-type accessories (option) (*5)	Alarm switch	(AL)	●	●	●	●	●		
	Auxiliary switch	(AX)	●	●	●	●	●		
	Shunt trip	(SHT)	-	●	●	●	●		
	Undervoltage trip (UVT)	Non-Synchronous Closing (UVT-N)	-	●	●	●	●		
Accessories connection (option)	with Lead-wire terminal block	(SLT)	●	●	●	●	●		
	with Internal terminal type	(INT)	-	-	-	-	-		
	with Flying leads	-	●	●	●	●	●		
Built-in accessories (option)	Pre-alarm (contact output) (*3)	(PAL)	-	-	-	-	-		
	Overcurrent trip alarm (*3)	(OAL)	-	-	-	-	-		
External accessories (option)	Enclosure	Dustproof	(S)	●	●	●	●	●	
		(I)	-	-	-	-	-		
		Waterproof	(W)	-	●	●	●	●	
	Electrical operation device	(MD)	-	-	-	-	-		
	Mechanical interlock	(MI)	-	●	●	●	●		
	Handle lock device	Handle lock	(HL)	●	●	●	●	●	
		(HL-S)	-	-	-	-	-		
	Lock cover	(LC)	●	●	●	●	●		
	External operating handle	Mounted on breaker	(F)	-	●	●	●	●	
		Door mounting	(V)	-	●	●	●	●	
		(S)	-	●	●	●	●		
	Insulating barrier	Between phase	(BA-F)	-	●	●	●	●	
		To ground	(BA-G)	-	●	●	●	●	
		Large	(TC-L)	●	●	●	●	●	
	Terminal cover	Small	(TC-S)	●	●	●	●	●	
Transparent		(TTC)	●	●	●	●	●		
for rear connection		(BTC)	●	●	●	●	●		
for plug-in		(PTC)	-	●	●	●	●		
Marine approval	L/R	G/L	-	●	●	●	●		
		BV	-	●	●	●	●		
		DNV	-	●	●	●	●		
		ABS	-	●	●	●	●		
		Hydraulic-magnetic	-	●	●	●	●		
Automatic tripping device	Hydraulic-magnetic	Hydraulic-magnetic	Hydraulic-magnetic	Hydraulic-magnetic	Hydraulic-magnetic	Thermal-magnetic			
Trip button	-	Equipped	Equipped	Equipped	Equipped	Equipped			

Note (*1) Use two poles for three- and four-pole products. If wired as shown on the right, three and four poles can be used for up to 400VDC and 500VDC, respectively.

(*2) Use two poles for three- and four-pole products. If wired as shown on the right, three and four poles can be used for up to 500VDC and 600VDC, respectively.

(*3) PAL and OAL are not available together. Only one can be specified.

(*4) Specify if for DC use.

(*5) Cassette-type accessories are not compatible with NF30-CS.

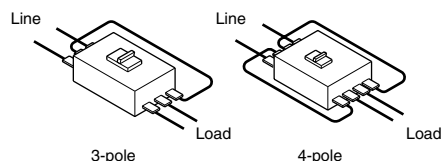

2. Detailed Specifications

Molded-Case Circuit Breakers

Series		S Series						H Series									
Frame Size		160						160									
Image																	
Type name		NF160-SW		NF160-SGW RT		NF160-SGW RE		NF160-HW		NF160-HGW RT		NF160-HGW RE					
Rated current In (Amp.)		125 150 160		125-160		80-160		125 150 160		125-160		80-160					
Rated ambient temperature (°C)		40		40		40		40		40		40					
Number of poles		2 3 4		2 3 4		3 4		2 3 4		2 3 4		3 4					
Rated insulation voltage Ui (V)		690		690		690		690		690		690					
Rated short-circuit breaking capacities (kA)	IEC 60947-2 (Icu/Ics)	AC (50/60Hz)	690V	-	8/8	8/8	5/3	20/20	20/20								
			525V	-	22/22	22/22	-	35/35	35/35								
			500V	15/8	30/30	30/30	30/8	50/50	50/50								
			440V	25/13	36/36	36/36	50/13	65/65	65/65								
			415V	30/15	36/36	36/36	50/13	70/70	70/70								
			400V	30/15	36/36	36/36	50/13	75/75	75/75								
			380V	30/15	36/36	36/36	50/13	75/75	75/75								
			230V	50/25	85/85	85/85	100/25	100/100	100/100								
			DC	250V	15/8 (*1)	-	-	40/20 (*1)	-	-							
			300V	-	20/20 (*2)	-	-	40/40 (*2)	-	-							
Suitability for isolation		●		●		●		●		●		●					
Utilization category		A		A		A		A		A		A					
Reverse connection (terminals unmarked)		●		●		●		●		●		●					
Rated impulse withstand voltage Uimp (kV)		6		8		8		6		8		8					
Pollution degree		2		3		3		2		3		3					
Number of operating cycles		without current		12,000		40,000		40,000		12,000		40,000		40,000			
		with current		440V-In/2		4,000		30,000		30,000		4,000		30,000		30,000	
				440V-In		4,000		20,000		20,000		4,000		20,000		20,000	
				690V-In/2		-		1,000		1,000		1,000		1,000		1,000	
				690V-In		-		1,000		1,000		1,000		1,000		1,000	
Overall dimensions (mm)		without current		12,000		40,000		40,000		12,000		40,000		40,000			
		with current		440V-In/2		4,000		30,000		30,000		4,000		30,000		30,000	
		440V-In		4,000		20,000		20,000		4,000		20,000		20,000			
		690V-In/2		-		1,000		1,000		1,000		1,000		1,000			
		690V-In		-		1,000		1,000		1,000		1,000		1,000			
Mass of front-face type (kg)		without current		12,000		40,000		40,000		12,000		40,000		40,000			
		with current		440V-In/2		4,000		30,000		30,000		4,000		30,000		30,000	
		440V-In		4,000		20,000		20,000		4,000		20,000		20,000			
		690V-In/2		-		1,000		1,000		1,000		1,000		1,000			
		690V-In		-		1,000		1,000		1,000		1,000		1,000			
Installation and connections		Fixed		Front		Screw terminal		●		●		●		●			
						Solderless (box) terminal (SL)		●		●		●		●			
						Busbar terminal		-		-		-		-			
				Rear		(B)		●		●		●		●			
				Plug-in		Rear		(PM)		●		●		●			
				Rear/front IP20		(PM-IP)		●		●		●					
				IEC 35mm rail		Mounting hook (option)		-		-		-					
						Adapter (option)		-		-		-					
Cassette-type accessories (option)		Alarm switch		(AL)		●		●		●		●					
		Auxiliary switch		(AX)		●		●		●		●					
		Shunt trip		(SHT)		●		●		●		●					
		Undervoltage trip (UVT)		Non-Synchronous Closing (UVT-N)		-		-		-		-					
				Synchronous Closing (UVT-S)		-		-		-		-					
Accessories' connection (option)		with Lead-wire terminal block		(SLT)		●		●		●		●					
		with Internal terminal type		(INT)		-		-		-		-					
		with Flying leads		-		-		-		-		-					
Built-in accessories (option)		Pre-alarm (contact output) (*3)		(PAL)		-		-		-		-					
		Overcurrent trip alarm (*3)		(OAL)		-		-		-		-					
External accessories (option)		Enclosure		Dustproof		(S)		●		●		●					
				(I)		-		-		-		-					
				Waterproof		(W)		●		●		●		●			
						Electrical operation device		(MD)		●		●					
						Mechanical interlock		(MI)		●		●					
						Handle lock device		(HL)		●		●					
						Handle lock		(HL-S)		●		●					
						Lock cover		(LC)		●		●					
						External operating handle		Mounted on breaker		(F)		●		●			
								Door mounting		(V)		●		●			
								(S)		●		●					
						Insulating barrier		Between phase		(BA-F)		●		●			
								To ground		(BA-G)		●		●			
								Large		(TC-L)		●		●			
								Small		(TC-S)		●		●			
				Terminal cover		Transparent		(TTC)		●		●					
						for rear connection		(BTC)		●		●					
						for plug-in		(PTC)		●		●					
Marine approval				L/R		-		-		-		-					
				G/L		-		-		-		-					
				BV		-		-		-		-					
				DNV		-		-		-		-					
				ABS		-		-		-		-					
Automatic tripping device		Thermal-magnetic		Thermal-magnetic		Electronic		Thermal-magnetic		Thermal-magnetic		Electronic					
Trip button		Equipped		Equipped		Equipped		Equipped		Equipped		Equipped					

Note (*1) Use two poles for three- and four-pole products. If wired as shown on the right, three and four poles can be used for up to 400VDC and 500VDC, respectively.

(*2) Use two poles for three- and four-pole products. If wired as shown on the right, three and four poles can be used for up to 500VDC and 600VDC, respectively.

(*3) PAL and OAL are not available together. Only one can be specified.

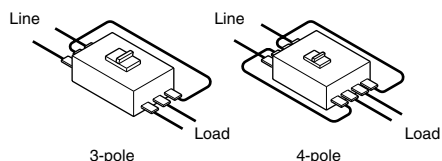

2. Detailed Specifications

Molded-Case Circuit Breakers

Series		C Series		S Series			H Series			
Frame Size		400		400			400			
Image										
Type name		NF400-CW		NF400-SW			NF400-SEW			
Rated current In (Amp.)		250 300 350 400		250 300 350 400			200~400 adjustable			
Rated ambient temperature (°C)		40		40			40			
Number of poles		2 3		2 3 4			3 4			
Rated insulation voltage Ui (V)		690		690			690			
Rated short-circuit breaking capacities (kA)	IEC 60947-2 (Icu/Ics)	AC (50/60Hz)	690V	10/10(5/5) (*1)			10/10(5/5) (*1)			
			500V	30/30(25/25) (*1)			30/30(25/25) (*1)			
			440V	42/42(36/36) (*1)			42/42(36/36) (*1)			
			415V	45/45(36/36) (*1)			50/50(36/36) (*1)			
			400V	45/45(36/36) (*1)			50/50(36/36) (*1)			
			380V	50/50(42/42) (*1)			50/50(42/42) (*1)			
			230V	85/85(65/65) (*1)			85/85(65/65) (*1)			
		DC	250V	20/10 *4			40/40 *4			
Suitability for isolation		●		●			●			
Utilization category		A		A			B			
Rated short-time withstand current Icw (kA)		-		-			5			
Reverse connection (terminals unmarked)		●		●			●			
Rated impulse withstand voltage Uimp (kV)		8		8			8			
Pollution degree		3		3			3			
Overall dimensions (mm)										
		a		140			185			
		b		257			257			
		c		103			103			
		ca		134			155			
Mass of front-face type (kg)		4.4 5.0		4.6 5.2 6.8			6.0 7.6			
Installation and connections	Fixed	Front	Screw terminal	●			●			
			Solderless (box) terminal (SL)	●			●			
			Busbar terminal	●			●			
			Rear	●			●			
Plug-in	Rear	(B)	●			●				
		(PM)	●			●				
		Rear/front IP20	(PM-IP)			●				
Cassette-type accessories (option)	Alarm switch	(AL)	●			●				
		Auxiliary switch	●			●				
		Shunt trip	●			●				
		Undervoltage trip (UVT)	●			●				
Accessories' connection (option)	with Lead-wire terminal block	Non-Synchronous Closing (UVT-N)	●			●				
		Synchronous Closing (UVT-S)	●			●				
		with Internal terminal type	●			●				
		with Flying leads	●			●				
Built-in accessories (option)	Pre-alarm (contact output) (*3)	(PAL)	-			● (*2)				
		Overcurrent trip alarm (*3)	(OAL)			-				
External accessories (option)	Enclosure	Dustproof	(S)	-			-			
			(I)	●			-			
			(W)	●			-			
	Electrical operation device	Motor-operated type	(MD)	●			●			
			Spring-charge type	(MDS)			●			
	Mechanical interlock	Handle lock device	(MI)	●			●			
			(HL)	●			●			
			(HL-S)	●			●			
	Lock cover	External operating handle	(LC)	-			-			
			Mounted on breaker	●			●			
			Door mounting	●			●			
			(S)	●			●			
			Insulating barrier	Between phase	(BA-F)	●			●	
					To ground	(BA-G)			●	
	Large	●			-					
Terminal cover	Small	(TC-L)	●			-				
		(TC-S)	-			-				
		Transparent	●			●				
		for rear connection	●			-				
		for plug-in	●			-				
Marine approval	L/R	(L/R)	●			-				
		(G/L)	●			-				
		(BV)	●			-				
		(DNV)	-			-				
		(ABS)	-			-				
Automatic tripping device		Thermal-magnetic		Thermal-magnetic			Electronic			
Trip button		Equipped		Equipped			Equipped			

- Note (*1) In case of solderless terminal, breaking capacity decreases to (/).
 (*2) Solid state relay output is option. Please specify if other output is necessary. (Standard type is with SLT equipped.)
 (*3) PAL and OAL are not available together. Only one can be specified.
 (*4) Use two poles for three- and four-pole products. If wired as shown on the right, three and four poles can be used for up to 400VDC and 500VDC, respectively.

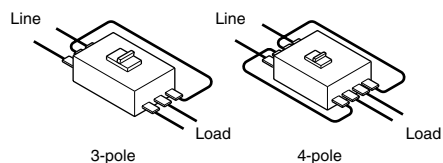

2. Detailed Specifications







Molded-Case Circuit Breakers

Series			C Series	S Series	H Series					
Frame Size			800	800	800					
Image										
Type name			NF800-CEW	NF800-SDW	NF800-SEW					
Rated current In (Amp.)			400-800 adjustable	(700) 800	400-800 adjustable					
Rated ambient temperature (°C)			40	40	40					
Number of poles			3	2	3 4					
Rated insulation voltage Ui (V)			690	-	690					
Rated short-circuit breaking capacities (kA)	IEC 60947-2 (Icu/Ics)	AC (50/60Hz)	690V	-	10/10	15/15				
			500V	18/9	-	30/30	50/50	70/35		
			440V	36/18	-	42/42	65/65	125/63		
					415V	36/18	-	50/50	70/70	125/63
					400V	36/18	-	50/50	70/70	125/63
					380V	40/20	-	50/50	70/70	125/63
					230V	50/25	-	85/85	100/100	150/75
		DC	250V	-	40/40 (*3)	-	-	-		
Suitability for isolation \rightarrow *			●	●	●					
Utilization category			B	A	B					
Rated short-time withstand current low (kA)			9.6	-	9.6					
Reverse connection (terminals unmarked)			●	●	●					
Rated impulse withstand voltage Uimp (kV)			8	8	8					
Pollution degree			3	3	3					
Overall dimensions (mm)										
			a	210	210 280					
			b	275	275					
			c	103	103					
			ca	155	155					
Mass of front-face type (kg)			10.9	9	10.9 14.2					
Installation and connections	Fixed	Front	Screw terminal	●	●					
		Solderless (box) terminal (SL)	●	●						
	Rear	Busbar terminal	●	●						
	Plug-in	Rear	(B)	●	●					
		Rear	(PM)	●	●					
		Rear/front IP20	(PM-IP)	-	-					
Cassette-type accessories (option) (*4)	Alarm switch		(AL)	●	●					
	Auxiliary switch		(AX)	●	●					
	Shunt trip		(SHT)	●	●					
	Undervoltage trip (UVT)		Non-Synchronous Closing (UVT-N)	●	●					
		Synchronous Closing (UVT-S)	●	●						
Accessories' connection (option)	with Lead-wire terminal block		(SLT)	●	●					
	with Internal terminal type		(INT)	-	-					
	with Flying leads		-	●	●					
Built-in accessories (option)	Pre-alarm (contact output) (*2)		● (*1)	-	● (*1)					
	Overcurrent trip alarm (*2)		(OAL)	-	-					
External accessories (option)	Enclosure	Dustproof	(S)	-	-					
		(I)	●	●						
		Waterproof	(W)	●	●					
	Electrical operation device	Motor-operated type	(MD)	●	●					
		Spring-charge type	(MDS)	●	●					
	Mechanical interlock		(MI)	●	●					
	Handle lock device	Handle lock	(HL)	●	●					
		(HL-S)	●	●						
	Lock cover		(LC)	-	-					
	External operating handle	Mounted on breaker	(F)	●	●					
		Door mounting	(V)	●	●					
	Insulating barrier	Between phase	(BA-F)	●	●					
		To ground	(BA-G)	●	●					
		Large	(TC-L)	●	●					
Terminal cover	Small	(TC-S)	-	-						
	Transparent	(TTC)	●	●						
	for rear connection	(BTC)	●	●						
	for plug-in	(PTC)	-	-						
Marine approval	L/R		●	-	●					
	G/L		●	-	●					
	BV		●	-	●					
	DNV		●	-	●					
	ABS		●	-	●					
Automatic tripping device			Electronic	Thermal-magnetic	Electronic					
Trip button			Equipped	Equipped	Equipped					

Note (*1) Solid state relay output is option. Please specify if other output is necessary. (Standard type is with SLT equipped.)
 (*2) PAL and OAL are not available together. Only one can be specified.
 (*3) Specify if for DC use.
 (*4) Cassette-type accessories are not compatible with NF1000-SW, NF1250-SW, NF1250-SDW, NF1600-SW, and NF1600-SDW.

2. Detailed Specifications

Earth-Leakage Circuit Breakers

Series	C Series	S Series	C Series	S Series	H Series	C Series	
Frame size	30	32	63	63	63	125	
Image							
Type name	NV30-CS	NV32-SW	NV63-CW	NV63-SW	NV63-HW	NV125-CW	
Rated current In (Amp.)	5 10 15 20 30	(5) 6 10 (15) 16 20 25 (30) 32	(5) (10) (15) 16 20 25 (30) 32 40 50 (60) 63	(5) (10) (15) 16 20 25 (30) 32 40 50 (60) 63	(15) 16 20 25 (30) 32 40 50 (60) 63	(60) 63 (75) 80 100 125	
Rated ambient temperature (°C)	40	40	40	40	40	40	
Number of poles	3	3	3	3	3	3	
Rated operational voltage Ue (AC V) (*6)	100-230	100-440 Multi-voltage type	100-440 Multi-voltage type	100-440 Multi-voltage type	100-440 Multi-voltage type	100-440 Multi-voltage type	
High-speed type	Rated current sensitivity IΔn (mA)	30	30, 100*200*500 Selectable	30, 100*200*500 Selectable	30, 100*200*500 Selectable	30, 100*200*500 Selectable	
	Max. operating time at 5IΔn (s)	0.04	0.04	0.04	0.04	0.04	
Time-delay type	Rated current sensitivity IΔn (mA)	-	-	-	-	(100*200*500) Selectable	
	Max. operating time at 2IΔn (s)	-	-	-	-	(0.45*1.0*2.0) Selectable	
	Inertial non-operating time at 2IΔn (s)	-	-	-	-	(0.1*0.5*1.0)	
Earth-leakage indication system		Button	Button	Button	Button	Button	
Rated short-circuit breaking capacity (kA) IEC 60947-2 2nd. ed. (Icu/Ics)	AC440V	-	5/2	2.5/1	7.5/4	10/5	
	AC400V	-	5/2	5/2	7.5/4	10/5	
	AC230V	2.5/2	10/5	7.5/4	15/8	25/13	
Number of operating cycles	without current	10,000	10,000	10,000	15,000	15,000	
	with current	440V-In/2 440V-In	6,000 (230V) 6,000 (230V)	6,000 6,000	6,000 6,000	15,000 8,000	6,000 6,000
Overall dimensions (mm)	a	67.5	75	75	75	90	
	b	96	130	130	130	130	
	c	52	68	68	68	68	
	ca	67	90	90	90	90	
Mass of front-face type (kg)	0.4	0.6	0.65	0.65	0.65	1.0	
Installation and connections	Fixed	Front	Screw terminal	●	●	●	
		Solderless (box) terminal (SL)	-	-	-	-	
		Busbar terminal	-	●	●	●	
	Plug-in	Rear	(B)	●	●	●	●
		Rear	(PM)	-	-	-	-
		Rear/front IP20	(PM-IP)	-	-	-	-
IEC 35mm rail	Mounting hook (option)	-	●	●	●	●	
	Adapter (option)	-	-	-	-	-	
Cassette-type accessories (option) (*2)	Alarm switch	(AL)	●	●	●	●	
	Auxiliary switch	(AX)	●	●	●	●	
	Shunt trip	(SHT)	-	-	-	-	
	Undervoltage trip (UVT)	Non-synchronous closing (UVT-N)	-	●	●	●	●
		Synchronous closing (UVT-S)	-	-	-	-	-
Built-in accessories (option)	Insulation switch	(MG)	●	●	●	●	
	Earth-leakage trip alarm	(EAL)	●	●	●	●	
	Test button module	(TBM)	-	●	●	●	
	Pre-alarm-contact output	(PAL)	-	-	-	-	
Accessories' connection (option)	with Lead-wire terminal block	(SLT)	●	●	●	●	
	with Flying leads	-	●	●	●	●	
External accessories (option)	Enclosure	Dustproof	(S)	●	●	●	
		(I)	-	-	-	-	
	Waterproof	(W)	●	●	●	●	
		(M)	-	-	-	-	
	Electrical operation device	(MD)	-	-	-	-	
	Mechanical interlock	(MI)	-	●	●	●	
	Handle lock device	(HL)	-	●	●	●	
		Handle lock	(HL-S)	-	●	●	●
	Lock cover	(LC)	●	●	●	●	
	External operating handle	Mounted on breaker	(F)	-	●	●	●
		Door mounting	(V)	-	●	●	●
			(S)	-	●	●	●
	Insulating barrier	Between phase	(BA-F)	-	●	●	●
		To ground	(BA-G)	-	●	●	●
Large		(TC-L)	●	●	●	●	
Terminal cover	Small	(TC-S)	●	●	●	●	
	Transparent	(TTC)	●	●	●	●	
	for rear connection	(BTC)	●	●	●	●	
	for plug-in	(PTC)	-	●	●	●	
Automatic tripping device	Hydraulic-magnetic	Equipped (*5)	Equipped	Equipped	Equipped	Thermal-magnetic	
Trip button	Equipped (*5)	Equipped	Equipped	Equipped	Equipped	Equipped	

Note (*1) 125A rated current is for 3P only.

(*2) Cassette-type accessories are not compatible with NV30-CS.

(*3) Standard type is with SLT equipped.

(*4) In case of ampere rating 15A and 16A, time-delay type is not available.

(*5) Included in AL (type) only.

(*6) Rated operational voltage of time-delay type is for 200-440V.

Rated operational voltage	Available voltage range
100 - 230V	80-253V
100 - 440V	80-484V
200 - 440V	160-484V

2. Detailed Specifications

Earth-Leakage Circuit Breakers

Series	C Series		S Series		H Series	
Frame size	400		400		400	
Image						
Type name	NV400-CW		NV400-SW		NV400-SEW	
Rated current In (Amp.)	250 300 350 400		250 300 350 400		200~400 adjustable	
Rated ambient temperature (°C)	40		40		40	
Number of poles	3		3		3 4	
Rated operational voltage Ue (AC V) (*3)	100~440 Multi-voltage type		100~440 Multi-voltage type		100~440 Multi-voltage type	
High-speed type	Rated current sensitivity IΔn (mA) (30) 100·200·500 Selectable		(30) 100·200·500 Selectable		(30) 100·200·500 Selectable	
	Max. operating time at 5IΔn (s)		0.04		0.04	
Time-delay type	Rated current sensitivity IΔn (mA) (100·200·500) Selectable		(100·200·500) Selectable		(100·200·500) Selectable	
	Max. operating time at 2IΔn (s)		(0.45·1.0·2.0) Selectable		(0.45·1.0·2.0) Selectable	
	Inertial non-operating time at 2IΔn (s)		(0.1·0.5·1.0)		(0.1·0.5·1.0)	
Earth-leakage indication system			Button		Button	
Rated short-circuit breaking capacity (kA) IEC 60947-2 2nd. ed (Icu/Ics)	AC440V		25/13		42/42(36/36) (*1)	
	AC400V		36/18		42/42(36/36) (*1)	
	AC230V		50/25		85/85(65/65) (*1)	
Suitability for isolation ↔			●		●	
Overall dimensions (mm)			a	140	140	140 185
			b	257	257	257
			c	103	103	103
			ca	134	155	155
Mass of front-connection type (kg)			5.6		6.6 8.2	
Installation and connections	Fixed	Front	Screw terminal	●	●	●
			Solderless (box) terminal (SL)	●	●	●
	Rear		Busbar terminal	●	●	●
			(B)	●	●	●
Plug-in	Rear	(PM)	●	●	●	
	Rear/front IP20	(PM-IP)	●	●	●	
Cassette-type accessories (option)	Alarm switch		(AL)	●	●	
	Auxiliary switch		(AX)	●	●	
	Shunt trip		(SHT)	●	●	
	Undervoltage trip (UVT)	Non-synchronous closing (UVT-N)		●	●	
Synchronous closing (UVT-S)		●	●			
Built-in accessories (option)	Insulation switch		(MG)	●	●	
	Earth-leakage trip alarm		(EAL)	●	●	
	Test button module		(TBM)	●	●	
	Pre-alarm-contact output		(PAL)	●	● (*2)	
	Overcurrent trip alarm		(OAL)	●	● (*2)	
Accessories connection (option)	with Lead-wire terminal block		(SLT)	●	●	
	with Flying leads			●	●	
External accessories (option)	Enclosure	Dustproof	(S)	●	●	
			(I)	●	●	
		Waterproof	(W)	●	●	
	Electrical operation device		(MD)	●	●	
	Mechanical interlock		(MI)	●	●	
	Handle lock device	Handle lock	(HL)	●	●	
			(HL-S)	●	●	
	Lock cover		(LC)	●	●	
	External operating handle	Mounted on breaker	(F)	●	●	
		Door mounting	(V)	●	●	
	Insulating barrier	Between phase	(BA-F)	●	●	
		To ground	(BA-G)	●	●	
		Large	(TC-L)	●	●	
	Terminal cover	Small	(TC-S)	●	●	
Transparent		(TTC)	●	●		
for rear connection		(BTC)	●	●		
for plug-in		(PTC)	●	●		
Automatic tripping device			Thermal-magnetic		Electronic	
Trip button			Equipped		Equipped	

Note (*1) In case of solderless terminal, breaking capacity decreases to (/).

(*2) Solid state relay output is option. Please specify if order output is necessary. (Standard type is with SLT equipped.)

(*3) Rated operational voltage of time-delay type is for 200-440V.

(*4) Specify if for CE marking. Type CE marking is only Front connection and Rear connection.

Rated operational voltage	Available voltage range
100 - 440V	80~484V
200 - 440V	160~484V

2. Detailed Specifications

Earth-Leakage Circuit Breakers for CE Marking

Series	S Series	C Series	S Series	H Series	C Series			
Frame size	32	63	63	63	125			
Image								
Type name	NV32-SW	NV63-CW	NV63-SW	NV63-HW	NV125-CW			
Rated current In (Amp.)	(5) 6 10 (15) 16 20 25 (30) 32	(5) (10) (15) 16 20 25 (30) 32 40 50 (60) 63	(5) (10) (15) 16 20 25 (30) 32 40 50 (60) 63	(15) 16 20 25 (30) 32 40 50 (60) 63	(60) 63 (75) 80 100 125			
Rated ambient temperature (°C)	40	40	40	40	40			
Number of poles	3	3	3	3	3			
Rated operational voltage Ue (AC V) (*4)	100-440 Multi-voltage type	100-440 Multi-voltage type	100-440 Multi-voltage type	100-440 Multi-voltage type	100-440 Multi-voltage type			
High-speed type	Rated current sensitivity IΔn (mA)	30,100-200-500 Selectable	30,100-200-500 Selectable	30,100-200-500 Selectable	30,100-200-500 Selectable			
	Max. operating time at 5IΔn (s)	0.04	0.04	0.04	0.04			
Time-delay type	Rated current sensitivity IΔn (mA)	-	-	-	(100-200-500) Selectable			
	Max. operating time at 2IΔn (s)	-	-	-	(0.45-1.0-2.0) Selectable			
	Inertial non-operating time at 2IΔn (s)	-	-	-	(0.1-0.5-1.0)			
Earth-leakage indication system	Button	Button	Button	Button	Button			
Rated short-circuit breaking capacity (kA) IEC 60947-2, EN 60947-2 (Icu/Ics)	AC440V	5/2	2.5/1	7.5/4	10/5			
	AC400V	5/2	5/2	7.5/4	10/5			
	AC230V	10/5	7.5/4	15/8	25/13			
Rated impulse withstand voltage Uimp (kV)	6	6	6	6	6			
Number of operating cycles	without current	10,000	10,000	15,000	15,000			
	with current	440V-In/2 440V-In	6,000 6,000	15,000 8,000	15,000 8,000	6,000 6,000		
Suitability for isolation \swarrow **	●	●	●	●	●			
Overall dimensions (mm)	a	75	75	75	90			
	b	130	130	130	130			
	c	68	68	68	68			
	ca	90	90	90	90			
	ca	90	90	90	90			
Mass of front-face type (kg)	0.6	0.65	0.65	0.65	1.0			
Installation and connections	Fixed	Front	Screw terminal	●	●	●	●	●
			Solderless (box) terminal (SL)	-	-	-	-	-
		Rear	Busbar terminal	●	●	●	●	●
	Plug-in	Rear	(B)	●	●	●	●	●
		IEC 35mm rail	(PM)	-	-	-	-	-
Cassette-type accessories (option)	Alarm switch	(AL)	●	●	●	●	●	
	Auxiliary switch	(AX)	●	●	●	●	●	
	Shunt trip	(SHT)	-	-	-	-	-	
	Undervoltage trip (UVT)	Non-synchronous closing (UVT-N)	●	●	●	●	●	
		Synchronous closing (UVT-S)	-	-	-	-	-	
Built-in accessories (option)	Insulation switch	(MG)	-	-	-	-	-	
	Earth-leakage trip alarm	(EAL)	-	-	-	-	-	
	Test button module (*3)	(TBM)	●	●	●	●	●	
	Pre-alarm-contact output	(PAL)	-	-	-	-	-	
Accessories's connection (option)	with Lead-wire terminal block	(SLT)	●	●	●	●	●	
	with Flying leads	-	●	●	●	●	●	
External accessories (option)	Enclosure	Dustproof	(S)	●	●	●	●	●
			(I)	●	●	●	●	●
		Waterproof	(W)	●	●	●	●	●
	Electrical operation device	(MD)	●	●	●	●	●	
	Mechanical interlock	(MI)	●	●	●	●	●	
	Handle lock device	Handle lock	(HL)	●	●	●	●	●
			(HL-S)	●	●	●	●	●
	Lock cover	(LC)	●	●	●	●	●	
	External operating handle	Mounted on breaker	(F)	●	●	●	●	●
		Door mounting	(V)	●	●	●	●	●
	Insulating barrier	Between phase	(BA-F)	●	●	●	●	●
			To ground	(BA-G)	●	●	●	●
			Large	(TC-L)	●	●	●	●
	Terminal cover	Small	(TC-S)	●	●	●	●	●
			Transparent	(TTC)	●	●	●	●
for rear connection			(BTC)	●	●	●	●	
for plug-in			(PTC)	-	-	-	-	
Automatic tripping device	Hydraulic-magnetic	Hydraulic-magnetic	Hydraulic-magnetic	Hydraulic-magnetic	Thermal-magnetic			
Trip button	Equipped	Equipped	Equipped	Equipped	Equipped			
CE marking	●	●	●	●	●			

Note (*1) 125A rated current is for 3P only.

(*2) In case of ampere rating 15A and 16A, time-delay type is not available.

(*3) Standard type is with SLT equipped.

(*4) Rated operational voltage of time-delay type is for 200-440V.

(*5) In case of ampere rating 125A, rear connection is not available.

Rated operational voltage	Available voltage range
100 - 440V	85-484V
200 - 440V	160-484V

2. Detailed Specifications

Earth-Leakage Circuit Breakers for CE Marking

Series	C Series		S Series		H Series			
Frame size	400		400		400			
Image								
Type name	NV400-CW		NV400-SW		NV400-SEW			
Rated current In (Amp.)	250 300 350 400		250 300 350 400		200~400 Adjustable			
Rated ambient temperature (°C)	40		40		40			
Number of poles	3		3		3 4			
Rated operational voltage Ue (AC V) (*3)	100~440 Multi-voltage type		100~440 Multi-voltage type		100~440 Multi-voltage type			
High-speed type	Rated current sensitivity IΔn (mA)	(30) 100·200·500 Selectable		(30) 100·200·500 Selectable		(30) 100·200·500 Selectable		
	Max. operating time at 5IΔn (s)	0.04		0.04		0.04		
Time-delay type	Rated current sensitivity IΔn (mA)	(100·200·500) Selectable		(100·200·500) Selectable		(100·200·500) Selectable		
	Max. operating time at 2IΔn (s)	(0.45·1.0·2.0) Selectable		(0.45·1.0·2.0) Selectable		(0.45·1.0·2.0) Selectable		
	Inertial non-operating time at 2IΔn (s)	(0.1·0.5·1.0)		(0.1·0.5·1.0)		(0.1·0.5·1.0)		
Earth-leakage indication system		Button		Button		Button		
Rated short-circuit breaking capacity (kA) IEC60947-2, EN60947-2 (Icu/Ics)	AC440V	25/13		42/42(36/36) (*1)		42/42(36/36) (*1)		
	AC400V	36/18		45/45(36/36) (*1)		50/50(36/36) (*1)		
	AC230V	50/25		85/85(65/65) (*1)		85/85(65/65) (*1)		
Rated impulse withstand voltage Uimp (kV)	8		8		8			
Number of operating cycles	without current	6,000		6,000		6,000		
	with current	1,000		1,000		1,000		
Suitability for isolation \rightarrow	440V-In/2 440V-In		1,000		1,000			
Overall dimensions (mm)		a	140		140		140 185	
		b	257		257		257	
		c	103		103		103	
		ca	134		155		155	
		ca	134		155		155	
Mass of front-face type (kg)	6.1		6.4		6.6 8.2			
Installation and connections	Fixed	Front	Screw terminal	-		-		
		Rear	Solderless (box) terminal (SL)	●		●		
		Busbar terminal	●		●			
Cassette-type accessories (option)	Plug-in	Rear	(B)	●		●		
		Alarm switch (AL)	-		-			
Built-in accessories (option)	Auxiliary switch	Shunt trip (SHT)	●		●			
		Undervoltage trip (UVT)	Non-synchronous closing (UVT-N)	●		●		
		Synchronous closing (UVT-S)	●		●			
Accessories' connection (option)	Insulation switch	(MG)	-		-			
		Earth-leakage trip alarm (EAL)	-		-			
		Test button module (TBM)	●		●			
		Pre-alarm-contact output (PAL)	-		● (*2)			
		Overcurrent trip alarm (OAL)	-		-			
External accessories (option)	Enclosure	Dustproof	(S)	-		-		
		(I)	●		-			
		Waterproof	(W)	●		-		
	Electrical operation device	(MD)	●		●			
		Mechanical interlock (MI)	●		●			
	Handle lock device	Handle lock	(HL)	●		●		
			(HL-S)	●		●		
	Lock cover	(LC)	-		-			
		External operating handle	Mounted on breaker	(F)	●		●	
			Door mounting	(V)	●		●	
	Insulating barrier	Between phase	(BA-F)	●		●		
			To ground	(BA-G)	●		●	
			Large	(TC-L)	●		-	
	Terminal cover	Small	(TC-S)	-		-		
			Transparent	(TTC)	●		●	
for rear connection			(BTC)	●		-		
for plug-in			(PTC)	-		●		
Automatic tripping device	Thermal-magnetic		Thermal-magnetic		Electronic			
Trip button	Equipped		Equipped		Equipped			
CE marking	●		●		●			

Note (*1) In case of solderless terminal, breaking capacity decreases to (/).

(*2) Solid state relay output is option. Please specify if order output is necessary. (Standard type is with SLT equipped.)

(*3) Rated operational voltage of time-delay type is for 200-440V.

Rated operational voltage	Available voltage range
100 - 440V	85~484V
200 - 440V	160~484V

2. Detailed Specifications

Motor-Protection Breakers

Frame A		30			50			100			225																		
Type name		MB30-CS			MB30-SW			MB50-CW			MB50-SW			MB100-SW			MB225-SW												
Rated current In (Amp.) Rated motor capacity: kW Reference ambient temperature 40°C (45°C for marine applications)	A	200/220V		400/440V	A	200/220V		400/440V	A	200/220V		400/440V	A	200/220V		400/440V	A	200/220V		400/440V									
		kW	kW	kW		kW	kW	kW		kW	kW	kW		kW	kW	kW		kW	kW	kW									
			32	7.5		15		32		7.5	15			45	11	22			7.1	1.5	–		100	–	55		225	55	110
			25	5.5		11		25		5.5	11			40	–	18.5			5	–	2.2		90	22	45		200	–	–
			16	3.7		7.5		16		3.7	7.5			32	7.5	15			4	0.75	1.5		63	15	30		175	45	90
			(12)	–		5.5		12		–	5.5			25	5.5	11			2.5	0.4	–		45	11	22		150	37	75
			10	2.2		–		10		2.2	–			16	3.7	7.5			2	–	0.75		(40)	–	19		125	30	–
			(8)	–		3.7		8		–	3.7			12	–	5.5			1.4	0.2	–		32	7.5	15				
			7.1	1.5		–		7.1		1.5	–			10	2.2	–			1.2	–	0.4		(25)	5.5	11				
			(5)	–		2.2		5		–	2.2			8	–	3.7			0.8	–	–		(12.5)	–	5.5				
	4	0.75	1.5		4	0.75	1.5																						
	2.5	0.4	–		2.5	0.4	–																						
	(2)	–	0.75		2	–	0.75																						
	1.4	0.2	–		1.4	0.2	–																						
	(1.2)	–	0.4		1.2	–	0.4																						
	(0.8)	–	–		0.8	–	–																						
Number of poles		2 (for single phase) 3			3			3			3			3			3												
Rated insulation voltage Ui (V)		500			500			500			500			500			500												
Rated short-circuit breaking capacities (kA)	IEC 60947-2 (Icu/Ics)	AC	440V	1.5/1.5 (415V)	2.5/1	2.5/1	7.5/4	25/13	25/13																				
			400V	1.5/1.5 (380V)	5/2	5/2	7.5/4	30/15	30/15																				
			230V	2.5/2 (240V)	7.5/4	7.5/4	15/8	50/25	50/25																				
Overall dimensions (mm)		a	45	67.5	75	75	75	90	105																				
		b	96		130	130	130	130	165																				
		c	52		68	68	68	68	68																				
		ca	67		90	90	90	90	92																				
Mass of front-connection type (kg)		0.25	0.35	0.55	0.55	0.55	0.95	1.5																					
Connection method	Front connection (F)	● Crimp contact		● Crimp contact		● Crimp contact		● Crimp contact		● Crimp contact		● Crimp contact																	
	Rear connection (B)	● Round stud (assembled in)		● Round stud		● Round stud		● Round stud		● Flat stud		● Flat stud																	
	Plug-in (PM)	–		●		●		●		●		●																	

Remark: 1. The products with rated current is parenthesized will be produced when an order is placed.

2. Detailed Specifications

UL Listed Products

2





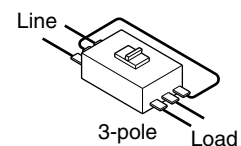



Frame A		100	225	50	100	150	250		400	600			
Type		NF100-CWU	NF225-CWU	NF50-SWU	NF100-SWU	NF-SFW	NF-SJW	NF-HJW	NF-SKW	NF-SLW			
Image													
Rated current In (Amp.) at ambient temperature 40°C (IEC30°C)		50 60 75 100	125 150 175 200 225	(3) 5 10 15 20 30 40 50	15 20 30 40 50 60 75 100	15 20 30 40 50 60 70 80 90 100 110 125 150	(125) (150) 175 200 225 250	125 150 175 200 225 250	250 300 350 400	500 600			
Number of poles		2 3	3	2 3	2 3	3	3	3	3	3			
Rated short-circuit breaking capacities (kA)	UL 489	AC	Rated voltage (V AC)		240	240	240	480Y/277	600Y/347	600Y/347	600Y/347	600Y/347	600Y/347
			600Y/347V	-	-	-	-	14	14	18	20	20	
			480V	-	-	-	-	35	35	50	35	35	
			480Y/277V	-	-	-	22	35	35	50	-	-	
	240V	10	35	14	35	65	65	100	65	85			
	IEC 60947-2 (Icu/Ics)	AC	Rated insulation voltage Ui (V)		600	600	600	690	690	690	690	690	690
			690V	-	-	-	8/4	8/8	8/8	15/15	10/10 (5/5) (*5)	10/10	
			500V	7.5/4	10/5	7.5/4	18/9	30/30	30/30	36/36	30/30 (25/25) (*5)	30/30	
			440V	10/5	15/8	7.5/4	25/13	36/36	36/36	50/50	42/42 (36/36) (*5)	42/42	
			415V	10/5	18/9	7.5/4	30/15	36/36	36/36	50/50	45/45 (36/36) (*5)	45/45	
			400V	10/5	18/9	7.5/4	30/15	36/36	36/36	50/50	45/45 (36/36) (*5)	45/45	
			380V	10/5	18/9	7.5/4	30/15	36/36	36/36	50/50	50/50 (42/42) (*5)	50/50	
			230V	30/15	35/18	15/8	50/25	85/85	85/85	100/100	85/85 (65/65) (*5)	85/85	
	DC	250V (*3)	7.5/4	10/5	-	15/8	20/20	20/20	20/20	-	-		
Compatible to AC/DC (*1)		●	●	-	●	●	●	●	●	-	-		
Suitability for isolation		●	●	●	●	●	●	●	●	●			
Reverse connection		●	●	●	●	●	●	●	●	●			
Overall dimensions (mm)		a	60 90	105	50 75	60 90	105	105	105	140	210		
		b	150	165	150	150	185	185	185	257	275		
		c	68	68	68	68	86	86	86	103	103		
		ca	90	92	90	90	110	110	110	155	155		
Mass of front-connection type (kg)		0.7 0.95	1.5	0.45 0.6	0.7 0.95	2.0	2.0	2.0	5.7	9.6			
Connection method	Front connection	Screw terminal (F)	●	●	●	●	●	●	●	-	-		
		Solderless terminal (box) (SL)	●	-	-	●	●	●	●	●	●		
		Busbar terminal (BAR)	●	●	●	●	●	●	●	●	●		
Accessories (*2) (option)	Alarm switch (AL)	●	●	●	●	●	●	●	●	●			
	Auxiliary switch (AX)	●	●	●	●	●	●	●	●	●			
	Shunt trip (SHT)	●	●	●	●	●	●	●	●	●			
	Under-voltage trip (UVT)	●	●	●	●	●	●	●	●	●			
	Vertical lead-wire terminal unit (SLT)	●	●	●	●	●	●	●	●	●			
External accessories (*2) (option)	Mechanical interlock (MI)	●	●	●	●	●	●	●	●	●			
	Handle lock device (HL)	●	●	●	●	●	●	●	●	●			
	Operating handle	F	●	●	●	●	●	●	●	●	●		
		S	●	●	●	●	●	●	●	●	●		
		V	●	●	●	●	●	●	●	●	●		
	Insulating barrier (IB)	●	●	●	●	●	●	●	●	●			
	Terminal cover	Large (TC-L)	●	●	●	●	●	●	●	●	●		
		Small (TC-S)	-	- (*4)	-	-	-	-	-	-	-		
IEC 35mm rail fixture	-	-	Supplied standardly	-	-	-	-	-	-				
Automatic tripping device		Thermal-magnetic	Thermal-magnetic	Hydraulic-magnetic	Thermal-magnetic	Thermal-magnetic	Thermal-magnetic adjustable	Thermal-magnetic adjustable	Thermal-magnetic	Thermal-magnetic adjustable			
Trip button		Equipped	Equipped	Equipped	Equipped	Equipped	Equipped	Equipped	Equipped	Equipped			
TUV type approval		●	●	●	●	●	●	●	●	●			

Note (*1) The trip action characteristics differ between AC and DC for products that are compatible with both AC and DC.
 (*2) Specifications for products with a CE mark differ from those for general-purpose products. Details are available upon request.
 (*3) Use two poles for three-pole products. If wired as shown on the right, NF100-CWU, NF100-SWU, and NF225-CWU can be used for up to 400VDC, and NF-SFW, NF-SJW, and NF-HJW can be used for up to 500VDC.
 (*4) The standard configuration includes a protection cover and adopts an IP20-compliant (finger protection) structure.
 (*5) In case of solderless terminal, breaking capacity decreases to (/).
 Remark: 1. Products with rated currents in parentheses () are special-order.
 The operating characteristics of breakers are different for AC and DC (JIS and IEC only).





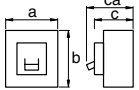





2. Detailed Specifications

Miniature Circuit Breakers

Type		BH			BH-P			
Frame (A)		70	100	100	70	100	100	
Image								
Number of poles		1	2	3	1	2	3	
Rated current (A) at ambient temperature 40° C		70	70,100	70,100	70	70,100	70,100	
Rated voltage (V)		AC	230/400			230/400		
		DC	125			125		
Breaking capacity (kA) sym.	IEC 60898	AC230/400V	3	—		3	—	
		AC400V	—	3		—	3	
	—	DC125V	1			1		
Type of instantaneous operation		Type C (5 In <, <10 In)						
Dimensions (mm)		a	25	50	75	25	50	75
		b	95			74		
		c	57.5			60.5		
		ca	77.5			79		
Mass (kg)		0.16	0.32	0.48	0.13	0.26	0.38	
Connection (*1)		Clamp terminal			Plug-in (line) Clamp (load)			
								
Automatic tripping device		Thermal, magnetic						
Optional accessories	Terminal cover	●			—			
	Mounting plate	●			—			
	Terminal base	—			●			
	Lock cover	●			●			
Approved by		—	LR, GL, NK	—	—	LR, BV, AB, GL, NK	—	

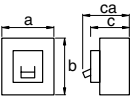







Note (*1) If required solderless terminal can be supplied.
(BH : Line and Load side, BH-P : Load side only)

Type		BH-S M3			BH-S M6			
Image								
Number of poles		1	2	3	1	2	3	
Rated current (A) at ambient temperature 40°C		5,10,15,20,(25),30,40,50,60	10,15,20,(25),30,40,50,60	15,20,(25),30,40,50,60	5,10,15,20,(25),30,40,50,60	10,15,20,(25),30,40,50,60	15,20,(25),30,40,50,60	
Rated voltage (V)		AC	230/400	400	400	230/400	400	
		DC	—	125	—	—	125	—
Breaking capacity (kA) sym.	IEC 60898	AC230/400V	3	—		6	—	
		AC400V	—	3		—	6	
	—	DC125V	—	1	—	—	1	—
Type of instantaneous operation		Types B,C,D (*2)						
Dimensions (mm) 	a	25	50	75	25	50	75	
	b	95			95			
	c	57.5			57.5			
	ca	76			76			
Mass (kg)		0.15	0.32	0.50	0.15	0.32	0.50	
Connection (*1)		Clamp terminal						
								
Automatic tripping device		Thermal, magnetic						
Optional accessories	Terminal cover	●						
	Mounting plate	●						
	Handle lock	●						
	Lock cover	—						
Approved by		—						

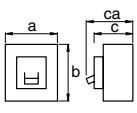

Note (*1) If required solderless terminal can be supplied. (Line and Load side)
 (*2) Type B (3 In <, ≤ 5 In), Type C (5 In <, ≤ 10 In), Type D (10 In <, ≤ 20 In)

2. Detailed Specifications

Miniature Circuit Breakers

Type		BH-PS M3			BH-PS M9			
Image								
Number of poles		1	2	3	1	2	3	
Rated current (A) at ambient temperature 40°C		10,15,20, 30,40,50,60	10,15,20, 30,40,50,60	15,20, 30,40,50,60	6,10,16,20,(25), 32,40,50,60	10,16,20,(25), 32,40,50,60	10,16,20,(25), 32,40,50,60	
Rated voltage (V)		AC	230/400	400	400	230/400	400	400
		DC	—	125	—	—		
Breaking capacity (kA) sym.	IEC 60898	AC230/400V	3	—		9	—	
		AC400V	—	3		—	9	
		DC125V	—	1	—		—	
Type of instantaneous operation		Types B,C,D (*1)						
Dimensions (mm)		a	25	50	75	25	50	75
		b	81.5			81.5		
		c	60.5			60.5		
		ca	79			79		
Mass (kg)		0.15	0.32	0.50	0.15	0.32	0.50	
Connection		Plug-in (line)			Clamp (load)			
								
Automatic tripping device		Thermal, magnetic						
Optional accessories	Terminal cover	—						
	Terminal base	●						
	Lock cover	—						
	Handle lock	●						
Approved by		—			LR			

Note (*1) Type B (3 In <, ≤ 5 In), Type C (5 In <, ≤ 10 In), Type D (10 In <, ≤ 20 In)

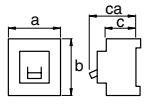
MCB		BH-D6 (IEC 60898)					BH-DN (IEC 60898)
Image							
Number of poles		1	2	3	4 (3+N)	2 (1+N)	2 (1+N)
Rated current (A) at ambient temperature 30°C		6,10,13,16,20,25,32,40,50,63	6,10,13,16,20,25,32,40,50,63	6,10,13,16,20,25,32,40,50,63	6,10,13,16,20,25,32,40,50,63	6,10,13,16,20,25,32,40	6,10,16,20
Rated voltage (VAC)		230/400	400	400	400	230	230
Breaking capacity (kA) sym. (IEC 60898)		6					4.5
Tripping characteristics		Type B, C, D (*1)				Type B, C (*1)	Type C
Dimensions (mm) 	a	18	36	54	72	36	18
	b			87			88
	c			44			44
	ca			70			70
Mass (kg)		0.15	0.30	0.45	0.6	0.30	0.12
Connection		Solderless					
Automatic tripping device		Thermal, magnetic					
Optional accessories	Insulating barrier	—	1 pc	2 pcs	3 pcs	1 pc	—

Note (*1) Type B (3 In <, ≤ 5 In), Type C (5 In <, ≤ 10 In), Type D (10 In <, ≤ 20 In)

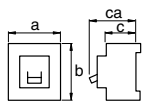
RCCB		BV-D (IEC 61008)	
Image			
Number of poles		2(1+N)	4(3+N)
Rated current (A) at ambient temperature 30°C		25, 40, 63	
Rated voltage (VAC)		230	230/400
Rated current sensitivity IΔn (mA)		30, 300	
Max. operating time (s) at 5IΔ		0.04	
Pulsating current sensitivity		Type AC	
Rated conditional short-circuit current (kA)		6	
Dimensions (mm) 	a	36	72
	b		85
	c		44
	ca		70
Mass (kg)		0.2	0.35
Connection		solderless	

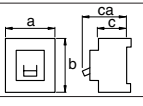
RCBO		BV-DN (IEC 61009)	
Photo			
Number of poles		2 (1+N)	
Rated current (A) at ambient temperature 30°C		6,10,16,20,25,32	
Rated voltage (VAC)		230	
Rated current sensitivity IΔn (mA)		30,100,300	
Max. operating time (s) at 5IΔn		0.04	
Pulsating current sensitivity		Type AC	
Breaking capacity (kA) sym. (IEC 61009)		4.5	
Tripping characteristics		Type C (*1)	
Dimension (mm) 	a	36	
	b	88	
	c	44	
	ca	70	
Mass (kg)		0.19	
Connection		Solderless	
Automatic tripping device		Thermal, magnetic	
Option		Over voltage release (280V±5%)	

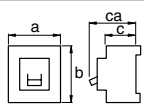
Isolating switch		KB-D (IEC 60947-3)			
Image					
Number of poles		1	2	3	4 (3+N)
Utilization category		AC22A class			
Rated current (A) at ambient temperature 30°C		32, 63, 80			
Rated voltage (VAC)		230	400		
Short time withstand current (A)		20 × In, 1s			
Short-circuit making capacity (A)		20 × In			
Dimensions (mm) 	a	18	36	54	72
	b			87	
	c			44	
	ca			70	
Mass (kg)		0.09	0.18	0.27	0.36
Connection		Solderless			
Optional accessories	Insulating barrier	—	1 pc	2 pcs	3 pcs

2. Detailed Specifications

ELRs and ZCTs

Earth-Leakage Relays

Type		Interchangeable leakage relays (*1)									
		Electrical self-hold type				Mechanical self-hold type					
		Electrical self-hold type		Mechanical self-hold type		Electrical self-hold type		Mechanical self-hold type			
Hole diameter mm		NV-ZBA		NV-ZSA		NV-ZHA		NV-ZLA			
Model name of ZCT combined (*5)	15	ZT15B	–	ZT15B	–	ZT15B	–	ZT15B	–		
	30	ZT30B	–	ZT30B	–	ZT30B	–	ZT30B	–		
	40	ZT40B	–	ZT40B	–	ZT40B	–	ZT40B	–		
	60	–	ZT60B	–	ZT60B	–	ZT60B	–	ZT60B		
	80	–	ZT80B	–	ZT80B	–	ZT80B	–	ZT80B		
	100	–	ZT100B	–	ZT100B	–	ZT100B	–	ZT100B		
Image											
Phase line type		3φ4W, 3φ3W, 1φ3W, 1φ2W									
Control voltage AC V		JIS	120 • 240 selectable		120 • 240 selectable 240 • 415 selectable		–		–		
		UL/JIS (*2) UL/CE (*3)	–		–		120 • 240 selectable 240 • 440 selectable		120 • 240 selectable 240 • 440 selectable 480		
JIS	High speed type	Rated sensitivity current mA	100 • 200 • 500 selectable		100 • 200 • 500 selectable		–		–		
		Max. operating time (s)	0.1		0.1		–		–		
	Delay type	Rated sensitivity current mA	100 • 200 • 500 selectable		100 • 200 • 500 selectable (200 • 500 • 1000 selectable)		–		–		
		Operating time (s) (#4)	0.3 • 0.8 • 1.6 selectable		0.3 • 0.8 • 1.6 selectable		–		–		
UL/JIS	High speed type	Rated sensitivity current mA	–		–		30 50		30 50		
		Max. operating time (s)	–		–		0.1		0.1		
	High speed • Delay type	Rated sensitivity current mA	–		–		100 • 200 • 500 selectable		100 • 200 • 500 selectable		
		Max. operating time (s) (#4)	–		–		0.1 • 0.45 • 1.0 selectable		0.1 • 0.45 • 1.0 selectable		
UL/CE	High speed type	Inertial non-operating time (s) or longer than (s)	0.1 • 0.5 • 1.1		0.1 • 0.5 • 1.1		– • 0.1 • 0.5		– • 0.1 • 0.5		
		Rated sensitivity current mA	–		–		30 • 50 • 100 selectable		30 • 50 • 100 selectable		
	Delay type	Max. operating time (s) at 5IΔn	–		–		0.04		0.04		
		Rated sensitivity current mA	–		–		100 • 300 • 500 selectable 300 • 500 • 1000 selectable		100 • 300 • 500 selectable 300 • 500 • 1000 selectable		
Earth-leakage indication	Resetting method	Electric type (LED)	Push button or control power switch off		Mechanical type (button)		Push button or control power switch off		Mechanical type (button)		
		Mechanical type (button)	Push button (combined with earth-leakage indicator)		Push button or control power switch off		Push button (combined with earth-leakage indicator)				
Built-in contact	Configuration		1c		1a1c		1a1c		1a1c		
	Continuous current capacity A		5		5		5		5		
	Contact capacity A	cosφ=1	cosφ=0.4 L/R=0.007	cosφ=1	cosφ=0.4 L/R=0.007	cosφ=1	cosφ=0.4 L/R=0.007	cosφ=1	cosφ=0.4 L/R=0.007	cosφ=1	cosφ=0.4 L/R=0.007
		120VAC	5	2	120VAC	5	3	120VAC	5	3	3
240VAC		5	2	240VAC	3	2	240VAC	5	2	2	
24VDC		5	2	415VAC	2	1	24VDC	5	2	480VAC	1
Connection		Front	● Clamp terminal		● Clamp terminal		○ Clamp terminal		○ Clamp terminal		
Standard attachment (Front connection)		Rear	–		○ Clamp terminal		○ Clamp terminal		○ Clamp terminal		
Mass kg		Relay		0.3		0.4		0.4		0.4	
External accessories	Terminal cover		○ (TC-ZBA)		○ (TC-ZSA)		○ (TC-ZSA) (#6)		○ (TC-ZSA) (#6)		
	Mounting hook for IEC 35mm rail (DIN rail) Fixture		○ (DIN-ZBA)		–		–		–		
Max. consumption VA		3		3		3		3			
Conforming standard	US UL standard (UR certified)		–		–		UL1053 Recognized component (File No.E196562)		UL1053 Recognized component (File No.E196562)		
	Canada CSA standard		–		–		LR103083(Certified No.)		LR103083(Certified No.)		
	European CE marking		–		–		Declaration for conformity IEC 60947-2 AnnexB EN 60947-2 AnnexB		Declaration for conformity IEC 60947-2 AnnexB EN 60947-2 AnnexB		

Note (*1) Interchangeable leakage relays can be easily combined with other relays and our ZCT. However, products with 30mA sensitivity (excluding NV-ZHA/ZLA) can only be used in combination with ZT15B, ZT30B and ZT40B.
 (*2) Indicates the UL-standard control voltage. UL, CSA and JIS standards are indicated together. For JIS voltage indications, 100-200V changeover is 120-240V changeover, 200-415V changeover is 240-440V changeover, and 460V and 480V are described together. When ordering, specify "UL/JIS".
 (*3) Indicates the UL-standard control voltage. UL, CSA and CE standards are indicated together. For CE voltage indications, 120-230V changeover is 120-240V changeover, 230-440V changeover is 240-440V selectable, which are described together. When ordering, specify "UL/CE".
 (*4) When operating times are 0.3 and 0.45sec, 0.8 and 1.0sec and 1.6sec, the relay operates between 0.15 and 0.45sec, 0.6 and 1.0sec and 1.2 and 2.0sec, respectively.
 (*5) Can be combined with an interchangeable ZCT equipped with a primary conductor. Refer to the next page for details.
 (*6) Not UL-certified.

Remark: 1. Relays with rates shown in parentheses () are special-order.
 2. The relay complies with CE marking conformity declaration only when used with CE marking type MITSUBISHI MCCB with a voltage tripping device to interrupt current during ground fault.
 3. NV-ZBA/ZSA

Control voltage	Available voltage range	Example of applicable circuit voltage
120V	80–126V	100 • 110V • 120V
240V	160–252V	200 • 220 • 240V
415V	320–484V	400 • 415 • 440V

4. NV-ZHA/ZLA

Control voltage	Available voltage range	Example of applicable circuit voltage
120V	80–132V	100 • 110 • 120V
240V	160–264V	200 • 220 • 230 • 240V
440V	304–484V	380 • 400 • 415 • 440V
480V	368–528V	460 • 480V

Interchangeable ZCT

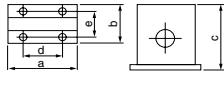
Type	ZT15B	ZT30B	ZT40B	ZT60B	ZT80B	ZT100B	
Aperture diameter (mm)	15	30	40	60	80	100	
Mass (kg)	0.2	0.4	0.6	2.0	2.6	3.3	
Rated short time current	50 (peak value)						
 Dimensions (mm)	a	48	68	85	140	160	185
	b	52	52	52	90	90	90
	c	70	90	100	150	169	190
	d	25	50	50	100	100	100
	e	40	40	40	70	70	70

ZCT aperture diameter and wire size

	ZCT aperture diameter (mm)	15	30	40	60	80	100
		Max. 600V rated wire size in mm ² (current in amperes)					
1ø2w	Polyvinyl chloride insulated wire	14 (88)	60 (217)	150 (395)	325 (650)	600 (992)	800 (1185)
	Cross-linked polyethylene insulated cable	2 (33)	38 (190)	60 (260)	250 (655)	400 (870)	600 (1140)
1ø3w 3ø3w	Polyvinyl-chloride insulated wire	8 (61)	38 (162)	100 (298)	250 (556)	500 (842)	725 (1095)
	Cross-linked polyethylene insulated cable	2 (33)	22 (135)	60 (260)	200 (560)	325 (760)	600 (1140)
3ø4w	Polyvinyl-chloride insulated wire	8 (61)	38 (162)	100 (298)	150 (395)	325 (650)	600 (992)
	Cross-linked polyethylene insulated cable	—	14 (105)	38 (190)	100 (365)	250 (655)	400 (870)

Interchangeable ZCTs with primary conductors

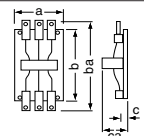
Type	ZTA600A	ZTA1200A	ZTA2000A	
Number of poles	3			
Rated voltage (VAC)	600			
Rated short time current (kA)	100 (peak value)			
	a	227	227	360
	b	256	298	250
	ba	366	444	594
	c	42	78	79
	ca	125	176	214

ELRs with a ZCT with primary conductors

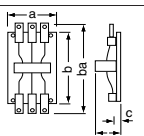

Frame (A)	600	1200	2000	3200	
Type	ZBA	Interchangeable ELR and interchangeable ZCTs with primary conductors			NV-ZBA3200
	ZSA				NV-ZSA3200
	ZHA				NV-ZHA3200
	ZLA				NV-ZLA3200
Number of poles	3				
Rated voltage (VAC)	600				
Rated short time current (kA)	100 (peak value)				
	a	227	227	360	490
	b	256	298	250	320
	ba	366	444	594	868
	c	42	78	79	111
	ca	125	176	214	290
Mass (kg)	6.5	11	27	54	

Specification of ELRs	High-speed type	Type	Control voltage (VAC)	Rated current sensitivity (mA)	Max. operating time (s)	Inertial non-operating time (s)
			ZBA	120 • 240 (*1)	100 • 200 • 500 (*1)	0.1
ZSA	120 • 240 (*1), 240 • 415 (*1)	100 • 200 • 500 (*1)				
Time-delay type (High-speed • Time-delay type)	ZBA	120 • 240 (*1)	100 • 200 • 500 (*1)	0.3 • 0.8 • 1.6 (*1)	0.1 • 0.5 • 1.1	
		120 • 240 (*1) 240 • 415 (*1)	100 • 200 • 500 (*1) (200 • 500 • 1000 (*1))	0.3 • 0.8 • 1.6 (*1)	0.1 • 0.5 • 1.1	
	ZHA	120 • 240 (*1) 240 • 440 (*1)	100 • 200 • 500 (*1)	0.1 • 0.45 • 1.0 (*1)	— • 0.1 • 0.5	
		100 • 300 • 500 (*1) 300 • 500 • 1000 (*1)	0.45 • 1.0 (*1) (at 2IΔn)	0.1 • 0.5 (at 2IΔn)		
	ZLA	120 • 240 (*1) 240 • 440 (*1) 480	100 • 200 • 500 (*1)	0.1 • 0.45 • 1.0 (*1)	— • 0.1 • 0.5	
100 • 300 • 500 (*1) 300 • 500 • 1000 (*1)	0.45 • 1.0 (*1) (at 2IΔn)	0.1 • 0.5 (at 2IΔn)				

Note (*1) Selectable.

2. Detailed Specifications

Circuit Protectors

Frame (A)		30						
Type		CP30-BA			CP-S			
Image								
Number of poles		1	2	3	1	2	3	
Rated insulation voltage Ui (V)		250			250			
Rated impulse withstand voltage Uimp (kV)		2.5			2.5			
Rated current (A)		0.1 0.25 0.3 0.5 1 2 3 5 7 10 15 20 30			0.05 0.1 0.25 0.3 0.5 0.75 1 2 2.5 3 5 7 7.5 10 15 20 25 30			
Rated short-circuit capacity (kA)	UL 1077 CSA C22.2 No.235 (*11)	Rated voltage (V)	AC (V)			DC (V)		
			65	125	–	250	65	–
		AC	2.5kA at 250V			1.5kA at 250V		
	IEC 60934 EN 60934 GB 17701 (*11) (Icn)	Rated insulation voltage Ui (V)	250			250		
			AC	250			1.5kA at 230V 2.5kA at 120V	
		DC	2.5kA at 60V	2.5kA at 120V	–	1kA at 60V	1kA at 120V (1kA at 60V) (*7)	1kA at 60V
	JIS C 4610 (Icn)	Rated insulation voltage Ui (V)	250			250		
			AC	2.5kA at 230V			1.5kA at 250V 2.5kA at 125V	
		DC	2.5kA at 60V	2.5kA at 120V	–	1kA at 65V	1kA at 125V (1kA at 65V) (*7)	1kA at 65V
	EN 60947-2 IEC 60947-2 JIS C 8201-2-1 Ann1 (Icu/Ics)	Rated insulation voltage Ui (V)	250			–		
			AC	2.5/2.5kA at 230V			–	
		DC	2.5/2.5kA at 60V	2.5/2.5kA at 120V	–	–		
AC-DC common use		●			– (*8)			
Reverse connection		●			–			
Rated short time current (for switch only type)		–			AC250V 50/60Hz 1500A 0.02s AC125V 50/60Hz 2500A 0.02s DC65V 1000A 0.02s DC125V 1000A 0.02s			
Rated ambient temperature (°C)		40 (T40)			25 (T25)			
Operating characteristics		Instantaneous type (I); Medium type (M), (MD); Slow type (S), (SD); Fast type (F) (*2)			Instantaneous type (I); Medium type (M), (MD); Slow type (S), (SD); Fast type (F) (FD)			
Mode of tripping		Instantaneous type (I): magnetic only [MO] Medium type (M), (MD) Slow type (S), (SD) : hydraulic-magnetic [HM] Fast type (F)			Instantaneous type (I): magnetic only [MO] Medium type (M), (MD) Slow type (S), (SD) : hydraulic-magnetic [HM] Fast type (F), (FD)			
Method of operation		S-type (IEC 60934)						
Trip-free behaviour		Trip-free (IEC 60934)						
Mass (kg)		0.08	0.16	0.23	0.06	0.12	0.18	
Accessories	Retractable small terminal cover (TC-S)	● Standard IP20 (front, terminal covers closed) [Certified of TUV]			–			
	Inertial delay (ID)	● (Medium, Slow type: AC only)			● (Medium, Slow, Fast type: AC only)			
	Alarm switch (AL)	● (1c)			● (1c) (*7)			
	Auxiliary switch (AX)	● (1c)			● (1c)			
	Shunt trip (SHT)	● (for relay type) (*3)			● (for parallel and relay type: AC only)			
	Large terminal cover (TC-L)	● (*6)			–			
	Flushpanel mounting brackets (FP)	●			–			
	Back facing wiring terminal (BT)	● (*4), (*6)			–			
	Lock cover (LC)	–			●			
Accessory terminal cover (TC)	● (*6)			–				
Connection	Main body	20A or less : Screw terminal M4 30A : Screw terminal M5			Male tub terminal 6.3mm (#250) [Screw terminal M4 (series type only)]			
	Alarm switch / Auxiliary switch	Screw terminal M3.5			Male tub terminal 2.8mm (#110)			
Main body mounting method		Surface, IEC rail mounting Flush panel mounting (option)			Panel mounting			
International standard		UL(cURus), CCC (*5)			UL(UR) (*9), (*10)			
CE Marking		EN 60934 : TUV approval EN 60947-2 : Self-declaration (*5)			EN 60934 : TUV approval (*10)			

- Note (*1) The 3-pole products are for AC use only.
 (*2) Contact us for operating characteristics other than those mentioned above.
 (*3) In poles equipped with a shunt tripping mechanism, the overcurrent tripping element is not operative (switched shunt tripping).
 (*4) For back-face wiring terminals, specify if it will be used with 30A, or 20A or less.
 (*5) UL(cURus), CCC, and CE Marking are displayed on standard products.
 (*6) It is recognition of UL(cURus), CCC, and TUV.
 (*7) In case of DC use, only DC65V is available.
 (*8) Specify if for DC use when ordering.
 (*9) Specify when ordering. (In case of CP-S UL, type name is CP-SU.)
 (*10) Connection is male tub terminal only.
 (*11) CP30-BA only.

Remark: 1. Products for non-standard conditions are special order. (Low temperature, 1st and 2nd-degree moisture fungal treatment, corrosion-resistant)
 2. Although a buzzing sound may occur when an instantaneous type becomes 80% or more of the rated current for AC use, performance is not effected. Please take this point into consideration when selecting units for use in quiet environments.
 3. Please use in environments free of high temperatures, humidity, dust, corrosive gas, vibration, and impact.
 Also, do not use it in a circuit with inrush current or harmonics. Problems may result.

3. Special-purpose Breakers

Mag Only, DC, and DSN

Mag Only (Instantaneous tripping circuit breakers)

Fixed	NF63-CW/SW/HW	AC, DC	Rated current x10
	NF125-CW/SW/HW	AC, DC	
	NF160-SW/HW	AC, DC	
	NF250-CW/SW/HW	AC, DC	
	NF400-CW/SW NF630-CW/SW	AC, DC	
Adjustable	NF125-SGW/HGW NF160-SGW/HGW NF250-SGW/HGW	AC, DC	High: Rated current x10 Low: Rated current x4 (AC) High: Rated current x13 Low: Rated current x5.2 (DC)
	NF800-SEW	AC	High: Rated current x10 Low: Rated current x2
	NF800-SDW	DC	High: 8000A Low: 3200A
	NF1000-SEW NF1250-SEW	AC	High: Rated current x10 Low: Rated current x2
	NF1600-SEW	AC	High: Rated current x10 Low: Rated current x2
	NF1250-SDW NF1600-SDW	DC	High: 8000A Low: 3200A

Remark: 1. The size, weight, accessories, etc., are all identical to the same-designation C, S and H series breakers.
2. For more details, contact your dealer.

DC MCCBs and DSN Switches

Breaking is more difficult with direct currents because the current value never reaches zero. While ordinary DC breakers are suitable for low voltages, special-voltage DC breakers are recommended for voltages in excess of 250VDC. Breakers for 550V are all 4-pole models.

The size, shape, drilling plan, accessories, etc., are all identical to the S Series breakers with the same designations.

Wiring diagram for DC-usage.

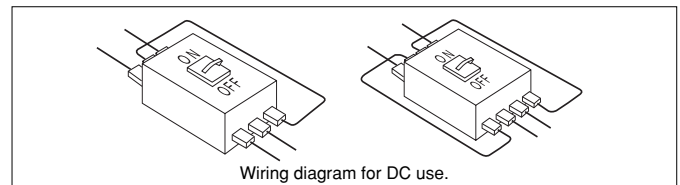

Remark: 1. The tripping characteristics will change if the wiring differs from the one shown here.

Type	NF63-SW	NF125-SW	NF160-SW	NF250-SW	NF400-SW	NF630-SW	NF800-SDW	NF1250-SDW	NF1600-SDW
Number of poles	3	3 4	3 4	3 4	3 4	3 4	3 4	3 4	3 4
Rated voltage (VDC)	400	440 550	440 550	440 550	500 600	500 600	500 600	500 600	500 600
Rated breaking capacity (kA) IEC 60947-2 (Icu/Ics)	2/1	10/5	20/5	20/5	40/40	40/40	40/40	40/20	40/20

Remark: 1. Time constant: 10ms or below.

●DC side

These breakers are designed as thyristor-Leonard system DC-side breakers. They protect the thyristor from short circuiting when there is a power or

communication failure (Mag-Only breakers can also be used for this purpose). Use these breakers in combination with fast fuses for even greater protection.

Type	NF125-SW	NF160-SW	NF250-SW	NF400-SW	NF630-SW	NF800-SDW	NF1250-SDW	NF1600-SDW
Number of poles	2 3	2 3	2 3	2 3	2 3	2 3	2 3	2 3
Rated voltage (VDC)	250 440	250 440	250 440	250 440	250 440	250 440	250 440	250 440
Rated breaking capacity (kA) IEC 60947-2 (Icu/Ics)	15/8 10/5	15/8 20/5	15/8 20/5	20/20	20/20	20/20	20/20	20/20
Instantaneous trip current (min.)	3 times rated current	3 times rated current	3 times rated current	900A	1000A	1400A	2500A	3200A

●DSN switches

These are standard MCCBs without the automatic tripping element. The tripping capacity is about six times the rated current.

The appearance, size, drilling plan and available accessories are all identical to similar standard S and C Series MCCBs.

Type	DSN30-CS	DSN63-CW	DSN125-CW	DSN250-CW	DSN400-CW	DSN630-CW	DSN800-CW
Rated current (A)	30	63	125	250	400	630	800
Number of poles	2 3	2 3	2 3	2 3	2 3	3	3
Rated voltage (AC/DC)	460/—	500/250	500/250	500/250	600/250	600/250	600/250
Max. switching current (AC/DC)	180/—	378/155	750/310	1500/625	2400/1000	3780/1575	4800/2000

Type	DSN32-SW	DSN63-SW	DSN125-SW	DSN125-SGW	DSN160-SGW	DSN250-SW	DSN250-SGW	DSN400-SW	DSN630-SW	DSN800-SW	DSN1000-SW	DSN1250-SW	DSN1600-SW
Rated current (A)	32	63	125	125	160	250	250	400	630	800	1000	1250	1600
Number of poles	2 3	2 3	2 3 4	2 3 4	2 3 4	2 3 4	2 3 4	2 3 4	3 4	3 4	3 4	3 4	3 4
Rated voltage (AC/DC)	500/250	500/250	690/250	690/300	690/300	500/250	690/300	690/250	690/250	690/250	690/250	690/250	690/250
Max. switching current (AC/DC)	192/80	378/155	750/310	750/315	960/400	1500/625	1500/625	2400/1000	3780/1575	4800/2000	6000/2500	7500/3125	9600/4000

3. Special-purpose Breakers

400Hz, Instantaneous, and Generator Protection

400Hz MCCBs

Standard MCCBs cannot be used in 400Hz circuits. When standard MCCBs are used in high-frequency circuits (eq. 400Hz), the instantaneous characteristics are shifted higher. The 400Hz MCCB is recommended for use in 400Hz circuits.

●Specifications

The appearance, size, rated interrupting capacity, drilling plan, accessories, etc., are all identical to the standard S and H Series breakers of the same designation.

Type	NF125-SW	NF125-HW	NF250-SW	NF250-HW	NF400-SW	NF400-SEW	NF630-SW (*1)	NF630-SEW	NF800-SEW	NF1250-SEW	NF1600-SEW
Rated current (A)	16, 20, 32, 40, 50, 63, 80, 100	16, 20, 32, 40, 50, 63, 80, 100	125, 150, 175, 200	125, 150, 175, 200	225, 250, 300, 350	200-350 adjustable	400, 500	300-500 adjustable	400-600 adjustable	600-800 adjustable	800-1200 adjustable
Number of poles	2 3 4	2 3 4	2 3 4	2 3 4	2 3 4	3 4	3 4	3 4	3 4	3 4	3 4
Rated insulation voltage (V)	690										
Rated breaking capacity (kA) IEC 60947-2 (Icu / Ics)	690V	8/4	10/5	—	5/3	10/10	10/10	10/10	10/10	25/13	25/13
	500V	18/9	30/15	15/8	30/8	30/30	30/30	30/30	30/30	65/33	65/33
	440V	25/13	50/25	25/13	50/13	42/42	42/42	42/42	42/42	85/43	85/43
	400V	30/15	50/25	30/15	50/13	45/45	50/50	50/50	50/50	85/43	85/43
230V	50/25	100/50	50/25	100/25	85/85	85/85	85/85	85/85	125/63	125/63	

Note (*1) Instantaneous trip current : Rated current x 14 (Fix)

Low-Instantaneous MCCBs

●Low-Inst. MCCBs for Discrimination

When a power fuse (PF) is used for high-voltage protection, make sure that the MCCB on the secondary side is compatible.

Type	NF125-CW	NF125-SW	NF250-CW	NF250-SW	NF400-CW
Number of poles	2 3	2 3 4	2 3	2 3 4	2 3
Rated current (A)	50, 63, 80, 100, 125	16, 20, 32, 40, 50, 63, 80, 100, 125	125, 150, 175, 200, 225, 250	125, 150, 175, 200, 225, 250	250, 300, 350, 400
Instantaneous trip (% of rated current)	600	●	●	●	●
	400	—	—	●	●

Remark: 1. Ensure compatibility with motor, etc., before use to prevent accidental tripping at start up.
2. Specify rated current and tripping characteristic.
3. There are no short time delay characteristics.

●Specifications

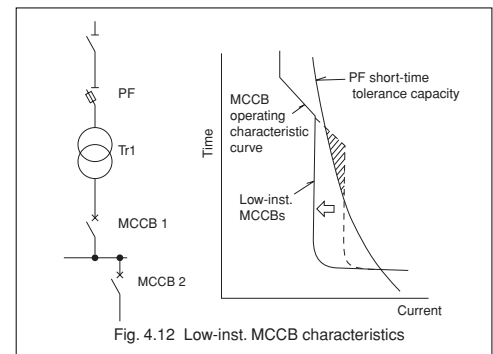

Fig. 4.12 Low-inst. MCCB characteristics
The appearance, size, rated interrupting capacity, accessories, etc., are all identical to the standard instantaneous trip breakers of the same designation.

Generator Protection MCCBs

These breakers are designed for generator protection.

●Specifications

Type	NF125-SGW	NF125-HGW	NF250-SGW	NF250-HGW
Number of poles	3	3	3	3
Rated current (A)	16-32, 32-63, 63-100, 75-125 adjustable	16-32, 32-63, 63-100, 75-125 adjustable	125-250 adjustable	125-250 adjustable
Instantaneous trip (% of rated current)	300 (*1)			
Operating time at 150% of rated current (s)	18-28 (*1)			
Rated insulation voltage (V)	690			
Rated breaking capacity (kA) IEC 60947-2 (Icu/Ics)	AC690V	8/8	20/20	8/8, 20/20
	AC500V	30/30	50/50	30/30, 50/50
	AC440V	36/36	65/65	36/36, 65/65
	AC400V	36/36	75/75	36/36, 75/75
	AC230V	85/85	100/100	85/85, 100/100

Note (*1) These MCCBs operating characteristic must be adjusted as follows.

STD ≤ 3 (Is setting)
LTD: minimum setting (TL = 12s setting)

3. Special-purpose Breakers

MDU Breakers

Measuring Display Unit (MDU) Breakers

- Energy management is now possible by measuring and displaying load current, line voltage, electric power, electric energy, harmonic current (3rd, 5th, 7th, 9th, 11th, 13th, 15th, 17th, 19th, and total), and power factor.
- Pulse output option displays electric current output.
CC-link option allows measurement data to be transferred to the CC-link open network.
- When a circuit breaker alarm activates, the LED on the MDU turns on.
PAL : Pre-alarm
OVER : Overcurrent
- When the circuit breaker trips, the cause of the fault and fault current are stored in the EEPROM, enabling investigation and restoration of the power line.
- The max. demand values of load current, line voltage, total harmonic current, electric power and current (per hour), are stored in the EEPROM.
MDUs equipped with the CC-Link option store the time when each item is measured, making it easy to identify peak times of power consumption.



NF400-SEP with MDU

Application type		Molded-Case Circuit Breaker			
Type		NF250-SW with MDU	NF400-SEP NF400-HEP with MDU	NF630-SEP NF630-HEP with MDU	NF800-SEP NF800-HEP with MDU
Frame size		250	400	630	800
Rated current In (Amp.)		125, 150, 175, 200, 225, 250	200-400 adjustable	300-630 adjustable	400-800 adjustable
Measured and displayed value	Load current (Present value, demand value, maximum demand value)	○	○	○	○
	Line voltage (Present value, maximum value)	○	○	○	○
	Harmonic current (Present value, demand value, maximum demand value)	○	○	○	○
	Electric power (Present value, demand value, maximum demand value)	○	○	○	○
	Electric energy, electric energy (hourly value), maximum electric energy (hourly value)	○	○	○	○
	Power factor (Present value)	○	○	○	○
	Rated measuring current	250A	400A	630A	800A
	Accuracy of measuring current (Limit deviation tolerance)	±6.25A	±10A	±15.76A	±20A
	Rated measuring voltage	AC440V			
	Accuracy of measuring voltage (Limit deviation tolerance)	±11V			
	Maximum measuring current (*1)	500A	800A	1260A	1600A
	Maximum measuring harmonic current (*1)	250A	400A	630A	800A
	Maximum measuring voltage (*1)	AC690V			
Measurement range of power factor	Lead 0.0~100.0~0.0 Lag(%), The value of power factor is reference value if less than 50%.				
Fault current/cause (*1) (*2) Overload and short-circuit (*3)	○ The fault cause: "AL" is displayed. The fault current: It displays it up to 10 times the rated current. ("AL switch for the MDU transmission" (option) is necessary.)		○ The fault cause: Overload "L" and short-circuit "SI" are displayed. The fault current: It displays it up to 16 times the maximum rated current.		
Alarm LED indication	PAL, OVER				
Phasing line	3φ3W, 1φ3W (3 poles breaker), 3φ4W (4 poles breaker)				
Electric energy accumulated pulse output (option) (*3)	○				
CC-Link transmission (option) (*3) (*4)	○				
Control power (Allowable voltage range 85~110%)	AC/DC100-240V 12VA (*5.)				
MDU installation	Breaker mounting	○			
	Panel mounting (*7)	○			
Alarm contact output (option) (*6)	Pre-alarm (PAL) (Power supply AC/DC100-240V required)	○ PAL			
	Trip indicator (TI) (Power supply AC/DC100-240V required)	–	○ PAL, OAL		

Note (*1) Maximum measurement values for current, voltage, harmonic current, and fault current are displayed in a flashing format when the input exceeds these values. (When a fault occurs, the cause of the fault and the value for fault current flash despite being less than the maximum measurement value). When electric power exceeds the max. measurement, the value of the current or voltage flashes.

(*2) Either overload (L) or short-circuit (SI) is displayed. They are not displayed simultaneously.

(*3) The pulse output option and CC-Link option cannot be attached at the same time.

(*4) "Ver.1.10" of CC-link is used when the breaker-mounted MDU is installed.

(*5) When control power is supplied to the MDU, the max. transitional rush current is 2A peak, 1ms (at 240VAC).

(*6) The pre-alarm (PAL) output function can be set to "Self-holding" or "Auto-reset". For the alarm contact output (PAL, OAL) to function, the MDU and circuit breaker must be connected, and control power must be supplied to the MDU and alarm contact output module.

(*7) A set of parts (panel holder plate, screws, nuts, MDU connection cable) is included for panel mounting. The standard length for the MDU connection cable is 2m, but it can be specified to be 0.5m, 3m, or as long as 5m.

3. Special-purpose Breakers

MDU Breakers

Measuring Display Unit

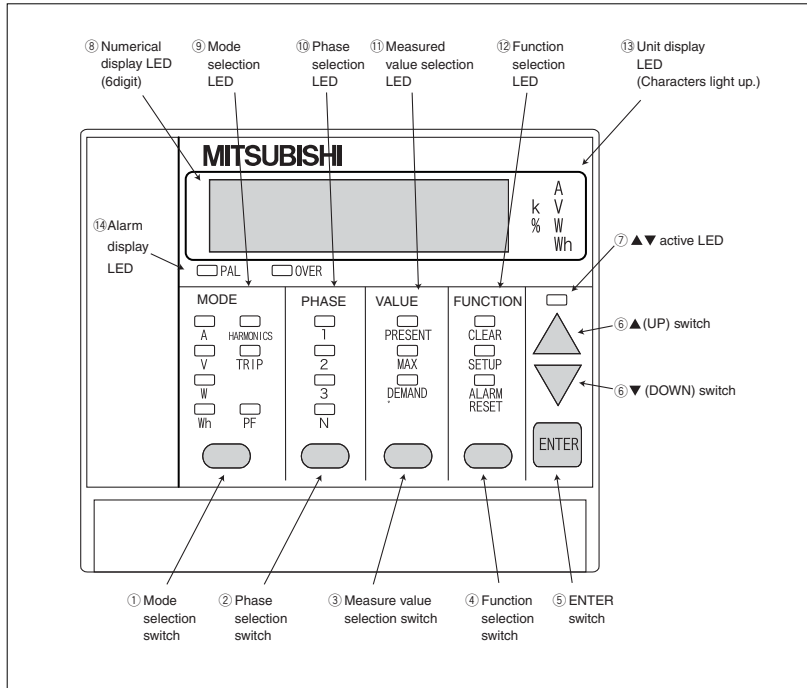

Displayed items and functions are changed by pushing ①~④ switch.

Selected item is shown by LED (below ⑨ - ⑫).

(Ex. Phase selection 1→2→3→N→1...)

▲/▼ switch⑥ is active when adjustment or reset operation is required.

(▲▼ active LED⑦ is turned on)

There may be functions which cannot be operated depending upon the specifications.

The invalid function is skipped.

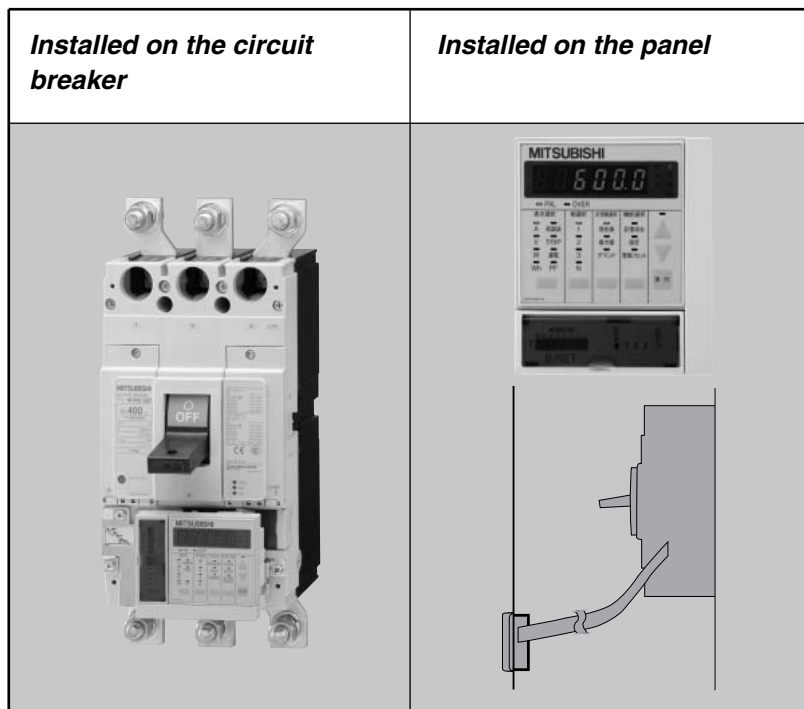

NF250-SW with MDU

Front-Connection

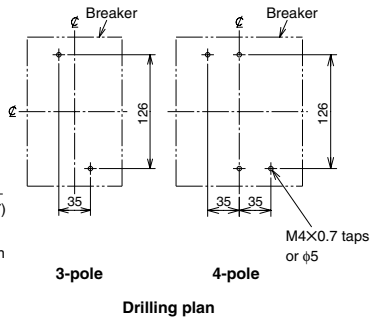
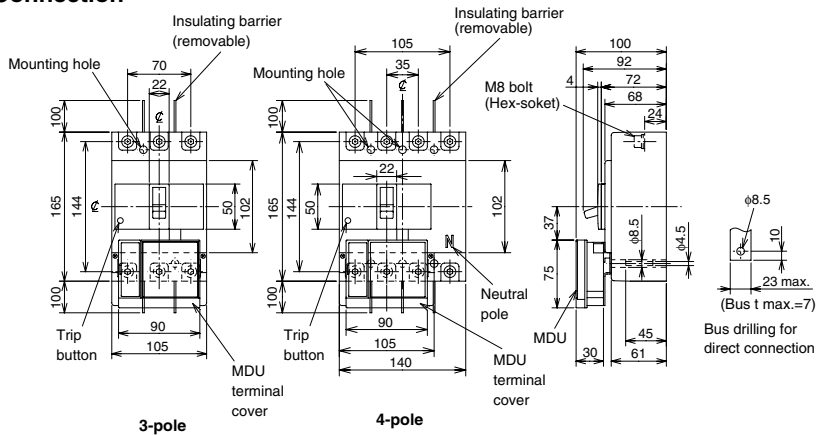

Rear-Connection

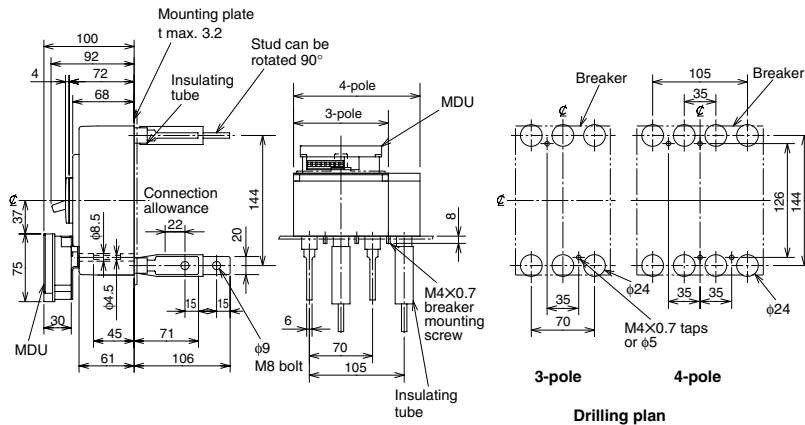

Front-plate cutout

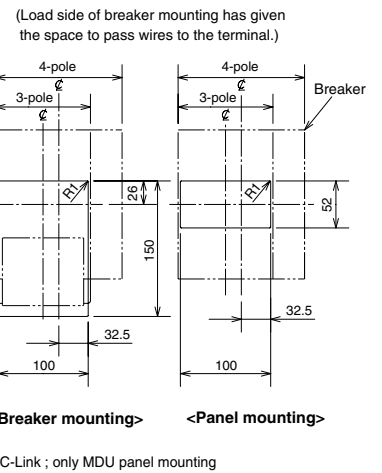

NF250-SW with MDU (No transmission, Pulse output)

MDU panel mounting

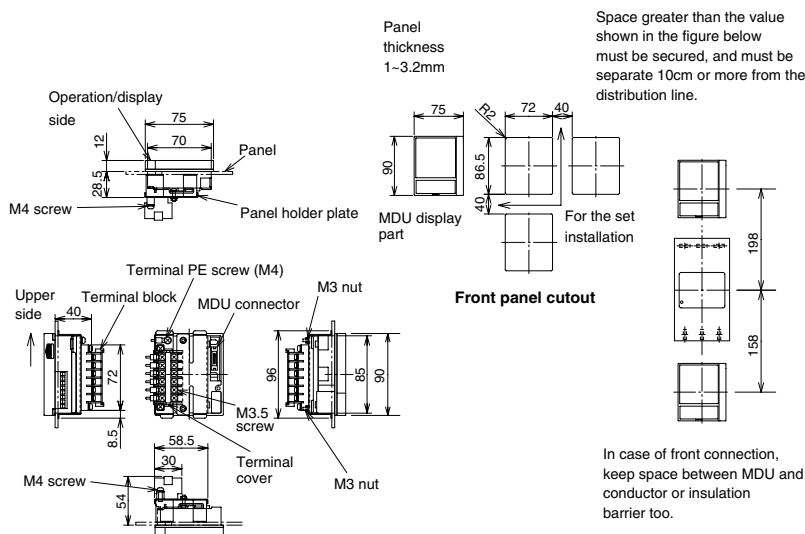

MDU Terminal

<Panel mounting>

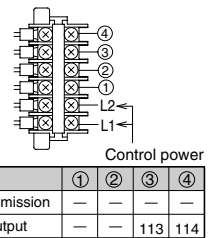

<Breaker mounting>

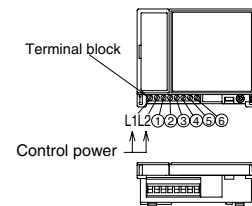

3. Special-purpose Breakers

MDU Breakers

NF250-SW with MDU (CC-Link)

MDU panel mounting MDU is connected with circuit breaker via MDU connection cable.

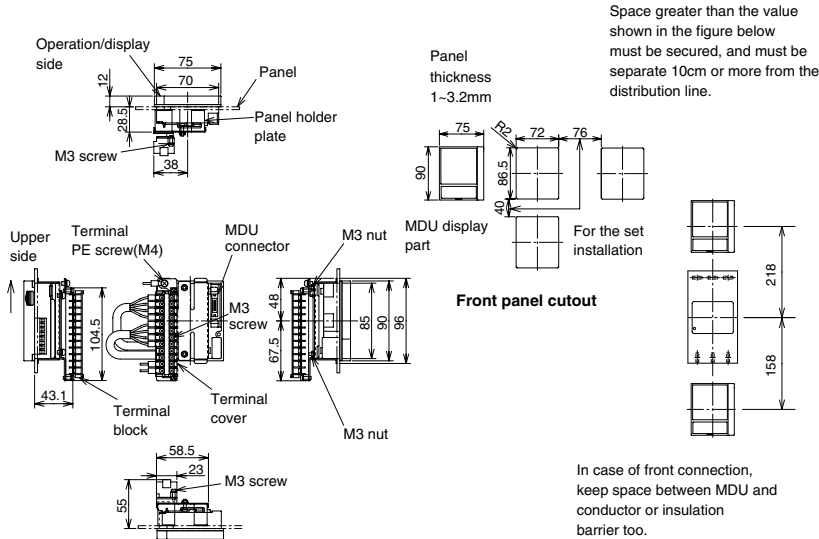

MDU Terminal Figure of the breaker mounting is removed the terminal cover.

<Panel mounting>

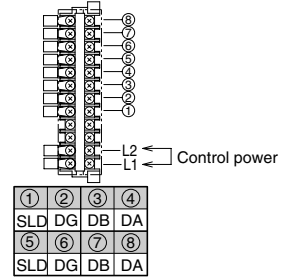

<Breaker mounting>

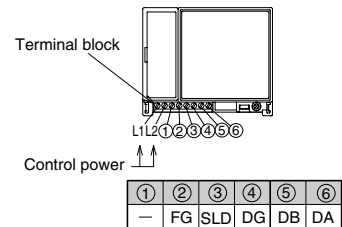

NF400-SEP, NF400-HEP with MDU

Front-Connection

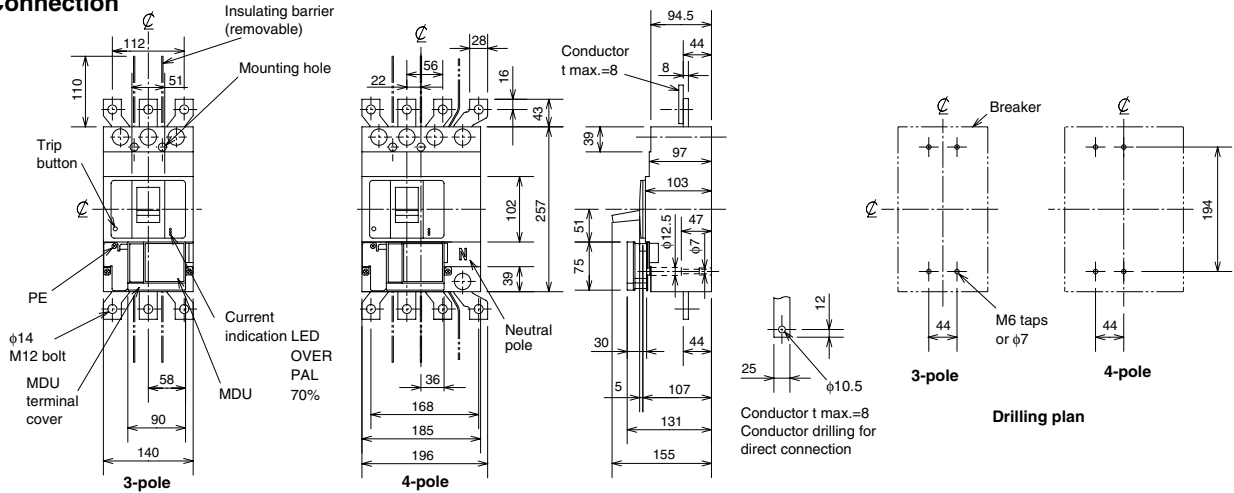

Rear-Connection

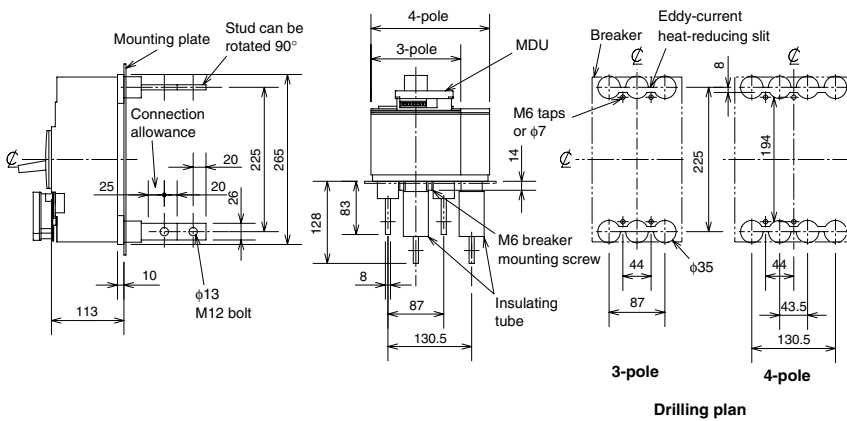

Note: The drilling plan is different if insulating barriers are installed.

Front-plate cutout

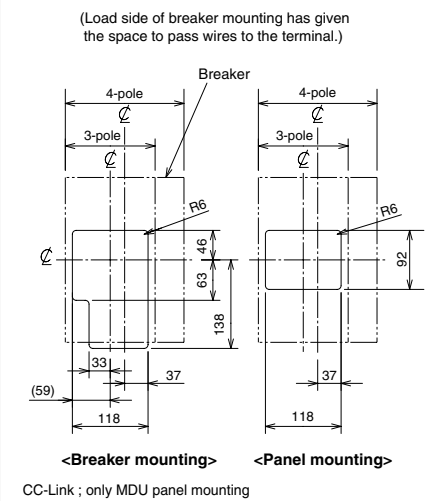

NF400-SEP, NF400-HEP, NF630-SEP, NF630-HEP, NF800-SEP, NF800-HEP with MDU (No transmission, Pulse output)

MDU panel mounting

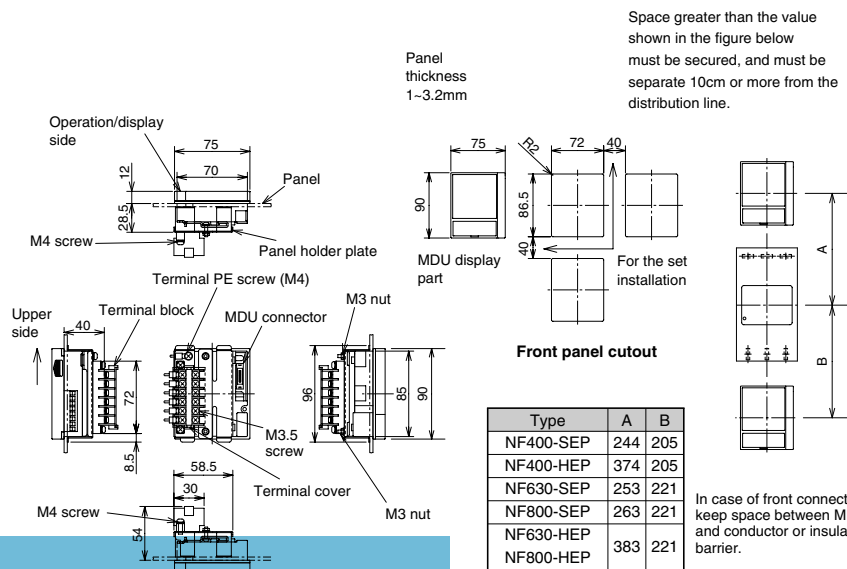

MDU Terminal

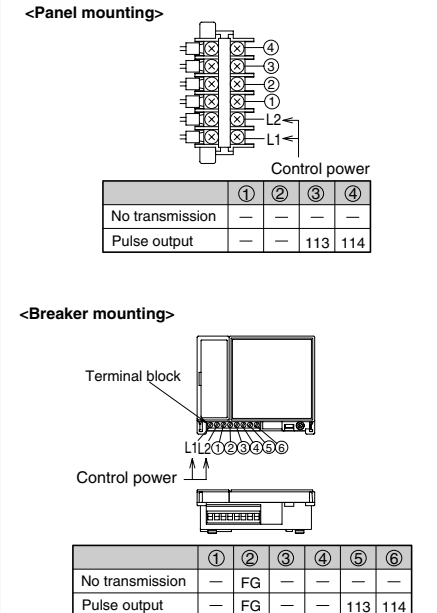

3. Special-purpose Breakers

MDU Breakers

NF630-SEP, NF630-HEP, NF800-SEP, NF800-HEP with MDU

Front-Connection

3-pole **4-pole**

Drilling plan

3-pole **4-pole**

Drilling plan

Conductor drilling for direct connection

Rear-Connection

3-pole **4-pole**

Drilling plan

Front-plate cutout

1mm clearance on each side of handle.
(Load side of breaker mounting has given the space to pass wires to the terminal.)

<Breaker mounting> **<Panel mounting>**

CC-Link ; only MDU panel mounting

Note: The drilling plan is different if insulating barriers are installed.

NF400-SEP, NF400-HEP, NF630-SEP, NF630-HEP, NF800-SEP, NF800-HEP with MDU (CC-Link)

MDU panel mounting

MDU is connected with circuit breaker via MDU connection cable.

Space greater than the value shown in the figure below must be secured, and must be separate 10cm or more from the distribution line.

Panel thickness 1-3.2mm

MDU display part For the set installation

Front panel cutout

Type	A	B
NF400-SEP	263	205
NF400-HEP	393	205
NF630-SEP	272	221
NF800-SEP	282	221
NF630-HEP	402	221
NF800-HEP	402	221

In case of front connection, keep space between MDU and conductor or insulation barrier.

MDU Terminal

Figure of the breaker mounting is removed the terminal cover.

<Panel mounting>



<Breaker mounting>

4. Connection Method

1. Connection Types

Table 4-1: Connection Types

The front connection model will be delivered unless otherwise specified. You can convert the front connection model to other types (excluding the plug-in) by using an appropriate connection component, which is separately available.

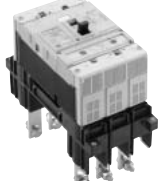
Connection Method (Abbreviation)	Front connection (F)	Solderless terminal	Rear connection (B)	Plug-in (PM)
Appearance				

2. Connection Accessories

Table 4-2: List of Connection Accessories

Type name		Solderless terminal (SL)	Rear studs (B-ST)	Plug-in (PM) (*1)
NF32-SW, NF63-CW/SW/HW	2P	-	ST-05SW2	PM-05SW2
NF32-SW, MB30-SW, MB50-CW/SW, NF63-CW/SW/HW, NV32-SW, NV63-CW/SW/HW	3P		ST-05SW3	PM-05SW3
NF63-SW/HW	4P		ST-05SW4	PM-05SW4
NF125-CW/SW	2P	SL-1SW4L (*3) SL-1SW4G (*4)	ST-1SW2	PM-1SW2
NF125-HW			ST-1HW2	PM-1HW2
NF125-CW/SW/HW, MB100-SW, NV125-CW/SW/HW	3P	SL-1SW3L (*3) SL-1SW3G (*4)	ST-1SW3	PM-1SW3
NV125-RW				PM-1UW3
NF125-SW/HW, NV125-SW/HW	4P	SL-1SW4L (*3) SL-1SW4G (*4)	ST-1SW4	PM-1SW4
NF250-CW/SW/HW, NF160-SW/HW	2P	SL-2SW4L (*5) SL-2SW4G (*6)	ST-2SW2	PM-2SW2
NF250-CW/SW/HW, MB225-SW, NF160-SW/HW, NV250-CW/SW/HW/RW/SEW/HEW	3P	SL-2SW3L (*5) SL-2SW3G (*6)	ST-2SW3	PM-2SW3
NV250-RW				
NF250-SW/HW, NF160-SW/HW, NV250-SW/HW/SEW/HEW	4P	SL-2SW4L (*5) SL-2SW4G (*6)	ST-2SW4	PM-2SW4
NF250-SGW/HGW, NF160-SGW/HGW, NF125-SGW/HGW	2P	SL-2GSW4	ST-2GSW2	PM-2GSWIP2 (*2)
NF250-RGW/UGW, NF125-RGW/UGW				PM-2GUW2
NF250-SGW/HGW, NF160-SGW/HGW, NF125-SGW/HGW	3P	SL-2GSW3	ST-2GSW3	PM-2GSWIP3 (*2)
NF250-RGW/UGW, NF125-RGW/UGW				PM-2GUW3
NF250-SGW/HGW, NF160-SGW/HGW, NF125-SGW/HGW	4P	SL-2GSW4	ST-2GSW4	PM-2GSWIP4 (*2)
NF250-UGW, NF125-UGW				-
NF400-CW/SW	2P	-	ST-4SW2	PM-4SW2
NF400-CW/SW/SEW, NV400-CW/SW/SEW	3P	-	ST-4SW3	PM-4SW3
NF400-HEW/REW, NV400-HEW/REW	3P	-	ST-4SW3	PM-4SW3
NF400-SW/SEW, NV400-SEW	4P	-	ST-4SW4	PM-4SW4
NF400-HEW, NV400-HEW	4P	-	ST-4SW4	PM-4SW4
NF630-CW/SW	2P	-	ST-6SW2	-
NF630-CW/SW/SEW, NV630-CW/SW/SEW	3P	-	ST-6SW3	-
NF630-HEW/REW, NV630-HEW	3P	-	ST-6SW3	-
NF630-SW/SEW, NV630-SEW	4P	-	ST-6SW4	-
NF630-HEW	4P	-	ST-6SW4	-
NF800-SDW	2P	-	ST-8SW2	PM-8SW2
NF800-CEW/SEW, NV800-SEW	3P	-	ST-8SW3	PM-8SW3
NF800-HEW/REW, NV800-HEW	3P	-	ST-8SW3	PM-8SW3
NF800-SEW	4P	-	ST-8SW4	PM-8SW4
NF800-HEW	4P	-	ST-8SW4	PM-8SW4

Note (*1) You can use the plug-in terminal unit (PM) when the wiring of terminal units is required in advance, and the delivery of both the main body and the components at the same time, which is normal, is not allowed. Furthermore specify the non-use of plug-in terminal (PM-N) for the connection of circuit breaker.

(*2) If safety device is necessary, please order.

(*3) Connected wire size: 2.5-25mm²

(*4) Connected wire size: 25-70mm²

(*5) Connected wire size: 14-95mm²

(*6) Connected wire size: 70-125mm²

3. Connection of Line and Load

The standard wiring of line and load on the circuit breaker is (a) normal connection shown on the right. Avoid the wiring shown in (b) reverse connection, which may lead to the decrease in breaking performance. However, the reverse connection is allowed for the following models (except NF models with MDU).

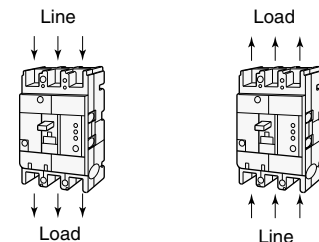

Normal connection (a) Reserve connection (b)

Normal and reverse connection methods

NF-C series, NF-S series, NF-H series, NF-U series, MB series, C·S·H series of NV400-800A Frame

Reverse connection is allowed for the standard models.

5. Accessories

Internal Accessories

1. Accessories

Table 5-1: Accessories

Internal accessories	Function	Applicable models	Cassette-type accessories
AL Alarm switch	Electrically indicates the trip status of the circuit breaker.	NF-C-S-H-U, NV-C-S-H-U and MB series	●
AX Auxiliary switch	Electrically indicates the ON-OFF status of the circuit breaker.		●
SHT Shunt trip	Electrically trips the circuit breaker from a remote distance. Permissible working voltages are 70 to 110% of the AC rated voltage or 70 to 125% of the DC rated voltage.	NF-C-S-H-U and MB series	●
UVT Undervoltage trip	Automatically trips the circuit breaker if the voltage is lowered. Working voltages are 70 to 35% of the UVT rated voltage. When the voltage recovers to 85% or higher, you can reset the device and restart operation.	NF-C-S-H-U, (*1) NV-C-S-H-U and MB series	●
EAL Earth-leakage alarm switch	Electrically indicates the trip status of the earth-leakage circuit breaker caused by a ground fault. If 250AF or less, this switch is available only for models with the vertical lead-wire terminal unit (SLT).	NV-C-S-H-U	-
TBM Test button module	Allows remote testing by applying a voltage. An external sequence common to SHT can be used. (The standard configuration requires the vertical lead-wire terminal unit (SLT).)	NV-C-S-H-U	-
MG Insulation switch	Enables measurement of insulation resistance between the terminals of the load while circuit breaker is turned OFF.	NV-C-S-H-U	-
PAL Pre-alarm module	Indicates that the load current exceeds the pre-alarm setting current.	Electronic type	-
OAL Overcurrent trip alarm switch	Indicates that the breaker has been tripped by overcurrent or short-circuit current.	Electronic type (SGW, HGW, RGW, UGW)	-

Note (*1) Excludes NV250-SEW/HEW models.

2. Switch Operation and Rating

Table 5-2: AL Switch Operation

Circuit breaker status	AL switch contact
 OFF or ON	 98/ALa (open) 96/ALb (closed) 95/ALc
 Trip	 98/ALa (closed) 96/ALb (open) 95/ALc

Table 5-3: AX Switch Operation

Circuit breaker status	AX switch contact
 OFF or Trip	 14/AXa (open) 12/AXb (closed) 11/AXc
 ON	 14/AXa (closed) 12/AXb (open) 11/AXc

Table 5-4: EAL Switch Operation

Circuit breaker status	EAL switch contact	
Overcurrent, short-circuit trip or on or off	250A frame or less	 EALa (open) EALc
	400A frame or more	 EALa (open) EALb (closed) EALc
Ground-fault trip	250A frame or less	 EALa (closed) EALc
	400A frame or more	 EALa (closed) EALb (open) EALc

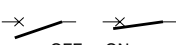
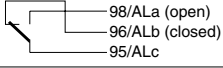
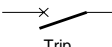
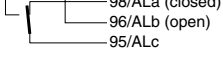
Table 5-5: MG Switch Operation

Circuit breaker status	MG switch status
 OFF or Trip	 MG switch (open)
 ON	 MG switch (closed)

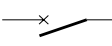
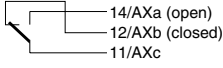
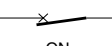
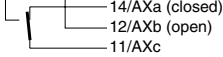
Table 5-6: AL-AX-EAL Switch Rating (For EAL, 400AF and higher)

Switch type	AC			DC		
	Voltage (V)	Current (A)		Voltage (V)	Current (A)	
		Resistive load	Inductive load		Resistive load	Inductive load
S	460	-	-	250	0.2	0.2
	250	3	2	125	0.4	0.4
	125	5	3	30	4	3
V	460	5	2	250	0.3	0.3
	250	10	10	125	0.6	0.6
	125	10	10	30	10	6
X (*1)	460	5	2.5	250	5	3
	250	10	10	125	10	6
	125	10	10	30	10	10

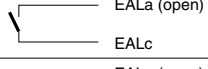
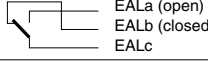
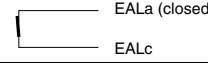
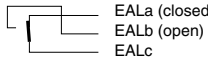
Note (*1) When DC polarity must be considered.

Please contact us for applications regarding smaller current values.

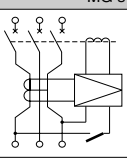
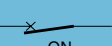
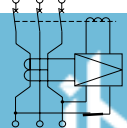
Table 5-7: EAL Switch Rating (250AF and less)

Voltage (V)	AC	
	Current A	
	Resistive load	Inductive load
200	3	2
100	3	2

A control power supply compatible with 100 and 200VAC is required; the wiring is shown on the right.

The permissible voltage range is 242VAC, and the power requirement is 10VA.

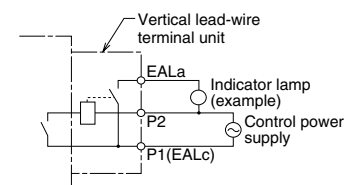

3. Maximum Number of Internally Mounted Accessories

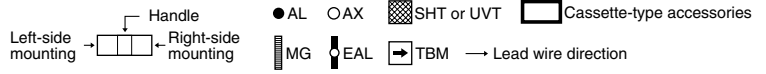

Table 5-8: Combinations of Accessories

Series		NF-C · S · H · U, MB			NV-C · S · H · U	
Type	NF30-CS MB30-CS	NF32-SW NF63-CW/SW/HW NF125-CW/SW	NF32-SW(3P) NF63-CW/SW/HW(3P) NF125-CW(3P), NF125-SW(3P, 4P) NF125-HW, NF125-SGW/HGW NF125-RGW/UGW NF160-SW/SW/HW/HGW NF250-CW/SW/HW NF250-SGW/HGW NF250-RGW/UGW MB30-SW, MB50-CW/SW MB100-SW, MB225-SW	NV30-CS	NV32-SW NV63-CW/SW/HW NV125-CW/SW/HW NV250-CW/SW/HW NV250-SEW/HEW NV125-RW, NV250-RW	
Poles	2, 3	2	2, 3, 4	3	3, 4	
Accessories	AL					
	AX					
	AL + AX					
	SHT or UVT					
	AL + SHT or UVT					
	AX + SHT or UVT					
	AL + AX + SHT or UVT					
	MG					
	AL + MG					
	AX + MG					
	EAL					
	TBM					
	PAL					

Circled numbers indicate the order of installation.

Note (*1) Second AX can substitute the AL on the left-pole.

(*2) Models with UVT require a UVT voltage module to be installed on the lead-wire terminal unit. (No such voltage module is required for SHT.) Part of UVT accessories is not of cassette type. (Details are available upon request.)

(*3) UVTs for left-pole installation can be produced, if specified, for frame current values of 125A (excluding SGW/HGW/RGW/UGW).

(*4) SHT cannot be installed.

(*5) EALs are available only for models with the vertical lead-wire terminal unit (SLT). Specify a control power supply of either 100 or 200 V AC.

(*6) Models NV250-SEW/HEW are not allowed to install the UVT device.

(*7) The standard lead drawing is performed laterally. Load drawing is also available.

(*8) Only the models with an SLT are available. EAL and PAL require a control power supply (shared 100 - 200 V AC).

For the 24 V DC TBM only, instruct us of a control voltage. (The standard shared voltage is 100 - 240 V AC/100 - 240 V DC.)

(*9) Models CE marking cannot install the TBM device.

Remark: 1. Accessories of EAL, and TBM can be installed independent of installations of AL, AX, and MG. (Two units among EAL, and TBM cannot be installed at the same time.)

5. Accessories

Internal Accessories

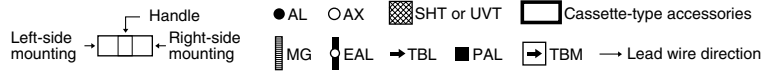

Series	NF-C · S · H · U		NF-S
Type	NF400-CW/SW NF400-SEW/HEW/REW NF630-CW/SW NF630-SEW/HEW/REW NF400-UEW (3P)	NF800-CEW/SDW NF800-SEW/HEW/REW NF400-UEW (4P), NF800-UEW	NF1000-SEW NF1250-SEW NF1600-SEW NF1250-SDW NF1600-SDW
Poles	2, 3, 4		
Switch type	S		V
Accessories	AL	(*3)	
	AX	(*3)	
	SHT or UVT	(*1) (*2)	(*2)
	AL + AX	(*3)	
	AL + SHT or UVT	(*1) (*2) (*3) (*4)	(*2) (*3) (*4)
	AX + SHT or UVT	(*1) (*2) (*3) (*4)	(*2) (*3) (*4)
	AL + AX + SHT or UVT	(*1) (*2) (*3) (*4)	(*2) (*3) (*4)
	PAL (contact output)	(*5) Option for NF400-SEW/HEW/REW/UEW(3P) NF630-SEW/HEW/REW	(*5) Option for NF400-UEW(4P) NF800-CEW/SEW/HEW/REW/UEW

Circled numbers indicate the order of installation.

Note (*1) SHT and UVT are right-pole mounting as standard. Please specify if left-pole mounting is required.

(*2) UVT mounting requires a UVT voltage module (SHT requires no such voltage module).

(*3) When mounting more than three left-pole mounting devices by SLT, or when mounting a SHT or UVT to the same pole as the AL, AX or AL + AX, a special type SLT is necessary.

(*4) When mounting a UVT to the same pole as the AL, AX, or AL + AX, the UVT voltage module is separate.

(*5) SLT-equipped is standard. Control voltage (AC100-200V) is necessary. (In this case, no other accessories can be mounted to the breaker's right pole.)

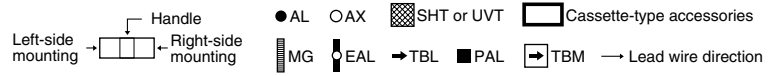

Series		NV-C · S · H	
Type	NV400-CW/SW NV400-SEW/HEW/REW NV630-CW/SW NV630-SEW/HEW		NV800-SEW/HEW
Poles		3, 4	
Switch type		S	
Accessories	AL		(*2)
	AX		(*2)
	SHT or UVT	(*1)	(*1)
	AL + AX	(*2)	(*2)
	AL + SHT or UVT	(*1) (*2) (*3)	(*1) (*2) (*3)
	AX + SHT or UVT	(*1) (*2) (*3)	(*1) (*2) (*3)
	AL + AX + SHT or UVT	(*1) (*2) (*3)	(*1) (*2) (*3)
	MG		
	AL + MG		

Note (*1) UVT mounting requires a UVT voltage module (SHT requires no such voltage module).
 (*2) When mounting more than three left-pole mounting devices by SLT, or when mounting a SHT or UVT to the same pole as the AL, AX or AL + AX, a special type SLT is necessary.
 (*3) When mounting a UVT to the same pole as the AL, AX or AL + AX the UVT voltage module is separate.

5. Accessories

Internal Accessories

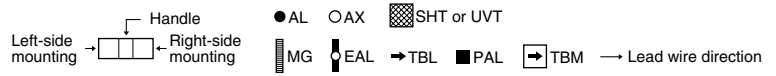

Series		NV-C · S · H	
Type	NV400-CW/SW NV400-SEW/HEW/REW NV630-CW/SW NV630-SEW/HEW	NV800-SEW/HEW	
Poles	3, 4		
Switch type	S		
Accessories	AX + MG		
	AL + AX + MG		
	EAL		
	TBL		
	TBM		
	PAL (contact output)	 Option for NV400-SEW/HEW/REW NV630-SEW/HEW	(#1)

Note (#1) SLT-equipped is standard. Control voltage (AC100-200V) is necessary. (In this case, no other accessories can be mounted to the breaker's right pole.)

Remark: 1. EAL, TBL, and TBM can be mounted regardless of the number of AL, AX, SHT, UVT and MG accessories. (However, two EALs, TBLs or TBMs cannot be mounted simultaneously.)

2. The PAL's dimensions and specifications change for the NF-C/S and NV-C/S series.

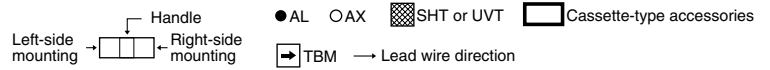

Series		NV-C · S · H · U for CE Marking	
Type		NV32-SW NV63-CW/SW/HW NV125-CW/SW/HW NV250-CW/SW/HW NV125-RW, NV250-RW	
Poles		3, 4	
Accessories	AL		
	AX		
	AL + AX		(*1)
	SHT or UVT		(*2) (*3)
	AL + SHT or UVT		
	AX + SHT or UVT		
	AL + AX + SHT or UVT		
	MG		
	AL + MG		
	AX + MG		
	EAL		
	TBM		(*4)
	PAL		

Note (*1) The second AX can substitute the AL on the left-pole.
 (*2) Models with UVT require a UVT voltage module to be installed on the lead-wire terminal unit. (No such voltage module is required for SHT.) Part of UVT accessories is not of cassette type. (Details will be available upon request.)
 (*3) SHT cannot be installed.
 (*4) Only the models with an SLT are available.
 For the 24 V DC TBM only, instruct us of a control voltage. (The standard shared voltage is 100 - 240 V AC/100 - 240 V DC.)
 Remark: 1. Accessories of TBM can be installed independent of installations of AL, AX. (TBM cannot be installed at the same time.)

5. Accessories

Internal Accessories

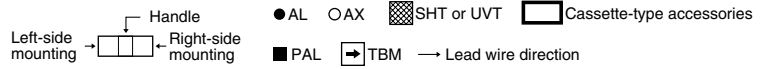

Series		NV-C · S · H for CE Marking	
Type	NV400-CW/SW NV400-SEW/HEW/REW NV630-CW/SW NV630-SEW/HEW	NV800-SEW/HEW	
Poles	3, 4		
Switch type	S		
Accessories	AL		(*2)
	AX		(*2)
	SHT or UVT	(*1)	(*1)
	AL + AX	(*2)	(*2)
	AL + SHT or UVT	(*1) (*2) (*3)	(*1) (*2) (*3)
	AX + SHT or UVT	(*1) (*2) (*3)	(*1) (*2) (*3)
	AL + AX + SHT or UVT	(*1) (*2) (*3)	(*1) (*2) (*3)
	TBM		
	PAL (contact output)	(*4) Option for NV400-SEW/HEW/REW NV630-SEW/HEW	(*4) Option for NV800-SEW/HEW

Note (*1) UVT mounting requires a UVT voltage module (SHT requires no such voltage module).

(*2) When mounting more than three left-pole mounting devices by SLT, or when mounting a SHT or UVT to the same pole as the AL, AX or AL + AX, a special-order SLT is necessary.

(*3) When mounting a UVT to the same pole as the AL, AX or AL + AX, the UVT voltage module is separate.

(*4) SLT-equipped is standard. Control voltage (AC100-200V) is necessary. (In this case, no other accessories can be mounted to the breaker's right pole.)

Remark: 1. TBM can be mounted regardless of the number of AL, AX, SHT, UVT accessories. (However, two TBMs cannot be mounted simultaneously.)

2. The PAL's dimensions and specifications change for the NF-C/S and NV-C/S series.

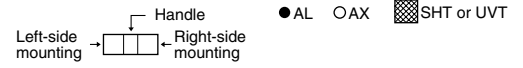

Series		NV-C · S · H for UL Listed					
Type	NF50-SWU NF100-CWU NF100-SWU	NF50-SWU NF100-CWU NF100-SWU	NF-SFW NF-SJW NF-HJW	NF225-CWU	NF-SKW	NF-SLW	
Poles	2	3			3		
Switch type	S					S	
Accessories	AL						(*5)
	AX						(*5)
	SHT or UVT	(*1)	(*1)	(*1)	(*2)	(*2)	(*2)
	AL + AX		(*3)	(*3)	(*3)	(*5)	(*5)
	AL + SHT or UVT		(*1)	(*1)	(*2)	(*1) (*4) (*5) (*6)	(*1) (*4) (*5) (*6)
	AX + SHT or UVT		(*1)	(*1)	(*2)	(*1) (*4) (*5) (*6)	(*1) (*4) (*5) (*6)
	AL + AX + SHT or UVT		(*1) (*3)	(*1) (*3)	(*2) (*3)	(*1) (*4) (*5) (*6)	(*1) (*4) (*5) (*6)

Circled numbers indicate the order of installation.

Note (*1) If a UVT is used, the UVT voltage module is installed on the lead wire terminal block. (The SHT requires no voltage module.)

(*2) If a UVT is used, the UVT voltage module is installed on the lead wire terminal block. (The SHT requires no voltage module.) No cassette is attached to the UVT.

(*3) The second AX can be installed instead of the AL on the left pole.

(*4) The standard mounting of the SHT and the UVT is performed on the right pole. If mounting on the left pole is required, contact us. (The UVTs for interlocks are mounted on the left pole.)

(*5) We can manufacture the SLTs used when 3 or more accessories are installed on the left pole and the SLTs used when the AL and the AX are attached on the same pole that is attached with the SHT or the UVT at your order.

(*6) If a UVT is used and an AL, an AX or an AL + an AX are attached to the same pole that is attached with the UVT, the UVT voltage module is separately installed.

5. Accessories

Internal Accessories

4. Shunt Trip (SHT)

Table 5-9: Standard Coil Rating

Series	Cut-off switch	Voltage (V)	Input power requirement (VA) (*1)		Operating time (ms) (*2)
			AC	DC	
NF-C • S • H • U MB NV-C • S • H • U	Equipped	AC100-240 380-550 (Compatible to 50 and 60Hz.) DC100-125	120	50	15 or less
				60	
		400 • 630 • 800 Frame NF400-CW/SW/SEW/HEW/REW/UEW NF630-CW/SW/SEW/HEW/REW/UEW NF800-SDW/CEW/SEW/HEW/REW/UEW NV400-CW/SW/SEW/HEW/REW/UEW NV630-CW/SW/SEW/HEW/REW/UEW NV800-SEW/HEW	AC100-450/DC100-200 (50 also 60Hz)	100V : 20 200V : 50 330V : 120 450V : 170	100V : 10 200V : 35
1000 • 1250 • 1600 Frame NF1000-SEW, NF1250-SEW/SDW NF1600-SEW/SDW	AC100-120 200-240 380-450 (50 also 60Hz) DC100	200	70	7-15	

Note (*1) Secure a sufficient input power so that the voltage will not drop below the permissible lower working voltage (70% of the lowest rated voltage).
(*2) The operating time denotes the time from when the rated voltage is applied to SHT until when the main contact of the breaker starts to open.

Table 5-10: Coil Ratings (List of manufacturable special voltages)

MCCB type	AC (V)				DC (V)								AC/DC (V)	
	24	24-48	48	380-550	12	24	24-36	36	36-48	48	110	125		220-250
NF-C • S • H • U MB 32(30) • 63A Frame 125A Frame 160 • 250A Frame	-	●	-	-	●	-	●	-	●	-	-	-	●	-
NF400-CW/SW/SEW/HEW/REW, NF630-CW/SW/SEW/HEW/REW NF800-SDW/CEW/SEW/HEW/REW, NF400-UEW, NF800-UEW NV400-CW/SW/SEW/HEW/REW, NV630-CW/SW/SEW/HEW/REW, NV800-SEW/HEW	-	-	-	●	●	-	-	-	-	-	-	-	-	●
NF1000-SEW, NF1250-SEW/SDW NF1600-SEW/SDW	●	-	●	-	●	●	-	●	-	●	●	●	-	-

5. Undervoltage Trip (UVT)

Table 5-11: Coil Rating

Series	Voltage (V) (*1)		Input power (VA)	Operating time (ms) (*2) (*3)
	Standard voltage	Special voltage (*5)		
250AF and less			5	30 or less
NF400-CW/SW/SEW/HEW/REW/UEW NF630-CW/SW/SEW/HEW/REW/UEW NF800-CEW/SDW/SEW/HEW/REW/UEW NV400-CW/SW/SEW/HEW/REW/UEW NV630-CW/SW/SEW/HEW/REW/UEW NV800-SEW/HEW	AC100-110/120-130 selectable 200-220/230-250 selectable 380-415/440-480 selectable (*4) DC100/110 selectable	AC24/48 selectable 500-550/600 selectable DC24/48 selectable 110/125 selectable	5	5-30
NF1000-SEW NF1250-SEW/SDW NF1600-SEW/SDW			5	5-35

Note (*1) A desired voltage can be selected by changing the terminal wiring.
(*2) The operating time denotes the time from when no voltage is applied to UVT until when the main contact of the breaker starts to open.
(*3) Time-delayed types can be produced. Details will be available upon request.
(*4) Compatible to 50 and 60Hz
(*5) Rated voltage differs according to make and country of manufacture. Please consult your dealer.

UVT Voltage Module

The UVT voltage module is normally installed on the vertical lead-wire terminal unit (SLT). (A separate-mount type can be produced upon request.)

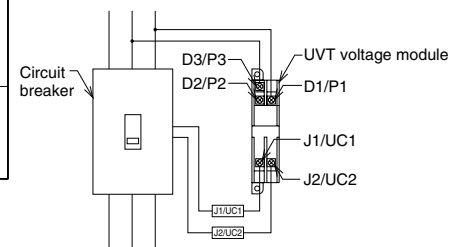

UVT Voltage Module Wiring Diagram (Lead-Wire Connection)

6. Test Button Module (TBM)

- Press the test button on the main body of the breaker while control voltage is applied to test the unit. (The voltage must be applied to the main body of the breaker for more than 2 sec when testing time-delayed NV models.)
- All models have a vertical lead terminal unit (SLT) as standard.

Table 5-12

Series	NV-C • S • H • U
Input rated control voltage (V)	Compatible with AC100-240/DC100-240 (DC24) (*1)
Input control power (VA)	1VA or less

Note (*1) 100-240VAC and 100-240VDC specifications are standard unless otherwise specified. Specifications for 24VDC are available upon request.

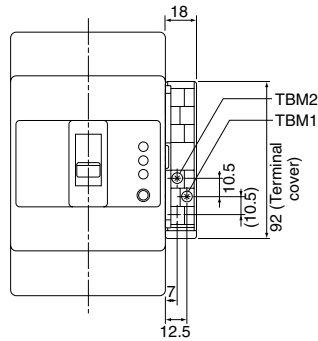

7. Lead-wire Specifications

Table 5-13

Series	Type	Size	Length	Marking	Ring-mark example
800AF and less	Heat-resistant wire	0.5mm ²	(*1) 450mm	A ring-mark with the terminal symbol is attached to each lead wire.	98/ALa, 96/ALb, 95/ALc
1000AF and over		0.75mm ²			C1/S1, C2/S2

Note (*1) 400mm for models with four poles and right-pole installation.

- Lead wires are normally extended laterally.
- Grooves are provided on the side of the breaker for extending lead wires on the side of the breaker (excluding models NF125-SGW/RGW/UGW, NF160-SGW/HGW, NF250-SGW/HGW/RGW/UGW, 400AF and higher).

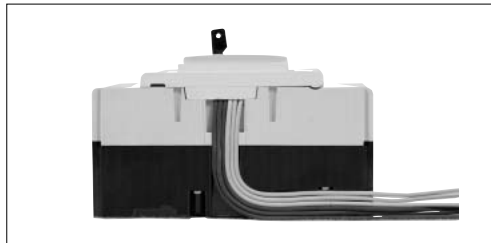

8. Internal Terminal (INT)

- An internal accessory including terminal screws for connecting lead wires.

Remark: 1. Available for NF125-SGW/HGW/RGW/UGW, NF160-SGW/HGW, NF250-SGW/HGW/RGW/UGW.

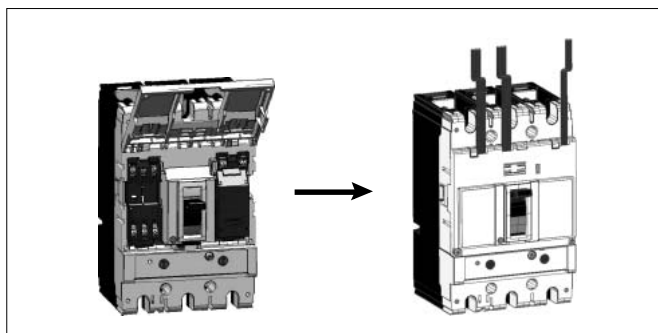

5. Accessories

Internal Accessories

9. Vertical Lead-wire Terminal Block (SLT)

- The circuit breaker can be mounted, being closely fitted to the unit.
- Terminal screws are arranged in a zigzag pattern, and screws can be tightened further after wiring.
- A terminal cover is provided.
- For models of front connection, rear connection, and plug-in type (excluding PLT).

■NFB

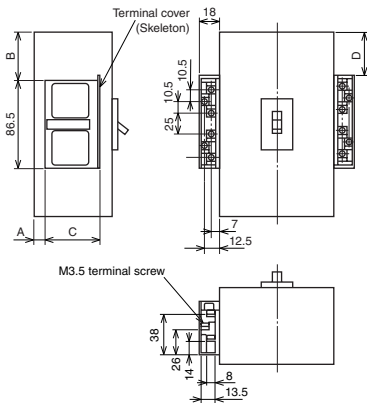

Table 5-14: Summary of Dimensions

Applicable models	A	B	C	D
NF30-CS, MB30-CS	4	4.5	44.5	4.5
NF32-SW, NF63-CW/SW/HW				
MB30-SW, MB50-CW/SW	7	17.5	54	17.5
NF50-SWU	7	27.5	54	27.5
NF125-CW/SW/HW	7	19	54	19
NF100-CWU, NF100-SWU	7	29	54	29
NF125-HGW, NF225-HGW	25	25	54	25
NF-SFW,NF-SJW, NF-HJW	25	35	54	35
NF250-CW/SW/HW, NF225-CWU, NF160-SW/HW	7	37	54	37
NF400-CW/SW/SEW/HEW/REW, NF-SKW, NF630-CW/SW/SEW/HEW/REW	41	79.5	54	79.5
NF800-CEW/SDW/SEW/HEW/REW, NF-SLW		88.5	54	88.5
NF1000-SEW, NF1250-SEW/SDW, NF1600-SEW/SDW	62.5	173	52	173
NF400-UEW(3P)		119.5	54	119.5
NF400-UEW(4P), NF800-UEW	138	135.5	54	135.5

Remark: 1. Terminal screw tightening torque M3.5 ... 0.9~1.2N·m

■NV

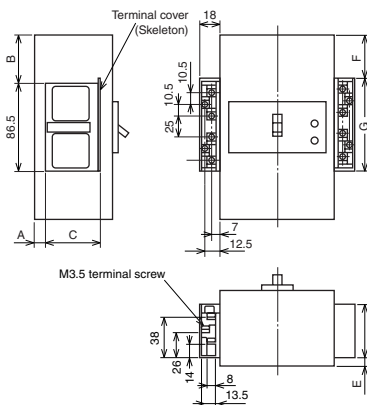

Table 5-15: Summary of Dimensions

Applicable models	A	B	C	D	E	F	G
NV30-CS	4	4.5	44.5	44.5	4	4.5	86.5
NV32-SW, NV63-CW/SW/HW	7	17.5	54	52	7	21.5	92
NV125-CW/SW/HW	7	19	54	54	7	19	86.5
NV250-CW/SW/HW, NV250-SEW/HEW, NV225-CWU	7	37	54	52	2.5	37	92
NV125-RW	7	80	54	54	7	80	86.5
NV250-RW	7	112	54	52	2.5	112	92
NV400-CW/SW/SEW/HEW/REW, NV630-CW/SW/SEW/HEW	41	79.5	54	52	26.5	79.5	92
NV800-SEW/HEW	41	88.5	54	52	26.5	88.5	92

Remark: 1. Terminal screw tightening torque M3.5 ... 0.9~1.2N·m
2. Lead-wire terminal block for TBL is attached to right-side.

■14 Terminals SLT

SLT for three and more than three pieces of internal accessories are mounted on left-side.

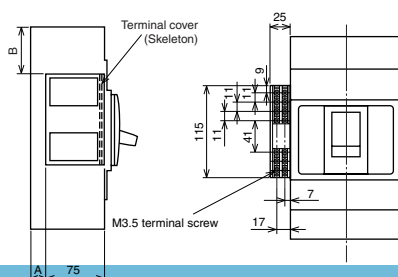

Table 5-16

Applicable models		A	B
NFB	NV		
NF400-CW/SW/SEW	NV400-CW/SW/SEW	20	60
NF400-HEW/REW, NF-SKW	NV400-HEW/REW		
NF630-CW/SW/SEW	NV630-CW/SW/SEW/HEW		
NF630-HEW/REW			
NF400-UEW(3P)	-	117	100
NF800-CEW/SDW/SEW	NV800-SEW/HEW	20	69
NF800-HEW/REW, NF-SLW			
NF1000-SEW, NF1250-SEW/SDW		35	154
NF1600-SEW/SDW			
NF400-UEW(4P), NF800-UEW	-	117	116

Remark: 1. Terminal screw tightening torque M3.5 ... 0.9~1.2N·m

10. Pre-Alarm Module (PAL)

This module gives an alarm when the load current exceeds a preset current level, securing a continuous power supply and preventing

problems before they occur. Electronic breakers equipped with a digital ETR of 125 to 1600AF are optional (standard for some modules).

Table 5-17

Type	Pre-alarm LED (Auto reset)	Solid-state relay (SSR) output-contact output (Auto reset)		Pre-alarm module-contact output (1a)		
		Switching capacity	(Self-holding)	Switching capacity	Reset system	
NF125-SGW/HGW	Standard equipment	Option	24VDC 100-200VAC 20mA	Option	100VAC or 200VAC 2A	Press the reset switch or turn off control power.
NF160-SGW/HGW						
NF250-SGW/HGW						
NV250-SEW/HEW		—				
NF400-SEW NF400-HEW NF400-REW NF400-UEW NF630-SEW NF630-HEW NF630-REW NF800-CEW NF800-SEW NF800-HEW NF800-REW NF800-UEW NV400-SEW NV400-HEW NV400-REW NV630-SEW NV630-HEW NV800-SEW NV800-HEW		Option	24VDC 100-200VAC 20mA			
NF1000-SEW NF1250-SEW NF1600-SEW						

- ① Pre-alarm LED The LED on the circuit breaker starts flashing when load current exceeds the preset current, then changes to a continuous display when the pre-alarm output is given.
- ② Solid-state relay output Open the upper cover of the circuit breaker, connect the lead-wire connector supplied, and use it as the lead wire outlet. In this case, only the lead wire outlet of the internal accessories can be attached to the right pole. (For flush-plate models, the outlet is already installed as a PAL mount.)
- ③ Pre-alarm module SLT is attached as standard and is used as the control power source of for 100VAC and 200VAC. In this case, no other internal accessories can be attached to the right pole. (Auto resetting is also possible.)

• Pre-alarm characteristics

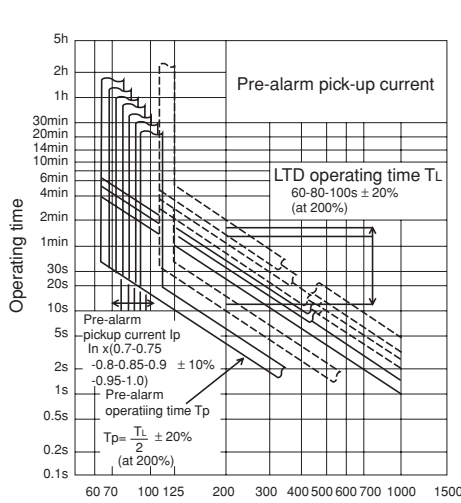

Percentage (%) to rated current or preset current rating (NF/NV125,250AF)

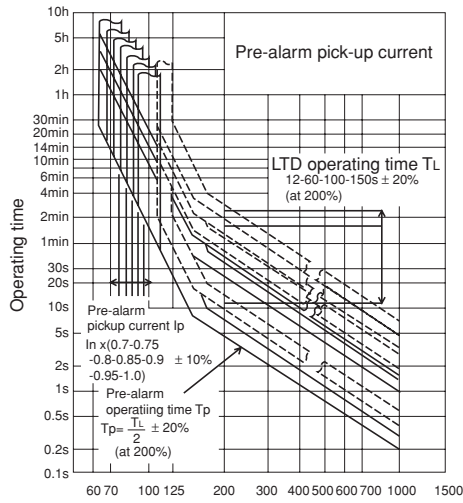

Percentage (%) to rated current or preset current rating (NF/NV400,630,800AF) (NF1000,1250,1600AF)

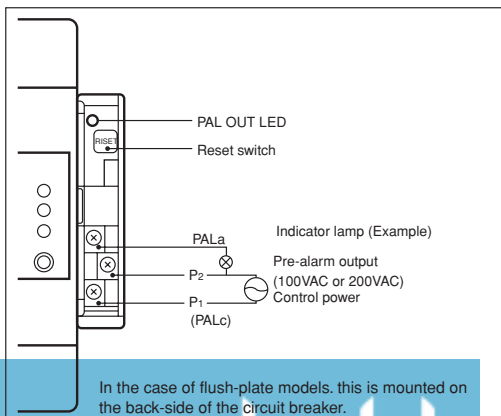

5. Accessories

Internal Accessories

11. 3ø4W Neutral-pole protection Relay (NR)

- In a 3-phase 4-wire circuits, the voltage rise of the circuit by phase failure of a neutral line is detected, and a contact output is taken out.

Table 5-18

Phase/wire type		3 ø 4W				
Rated voltage	VAC	415				
Usable supply voltage	VAC	304~484				
Tripping characteristics	Usable voltage (line voltage)	VAC	380	400	415	440
	Total operating overvoltage (phase voltage) (135% of total phase voltage)	VAC	296	312	323	343
	Total non-operating overvoltage (phase voltage) (120% of total phase voltage)	VAC	263	277	288	305
	Total overvoltage operating time	(s)	1			
Overvoltage non-operating time	(s)	More than 0.1				
Trip indication method	Button					
Reset method	Reset button (open-phase display use)					
External output contacts	1c					
	AC			DC		
	Voltage	cos ø		Voltage	L/R	
		1.0	0.4		0	0.007
	100, 120V	7A	7A	30V	7A	6A
	200, 240V	7A	7A	125V	0.6A	0.6A
415V	5A	2A	250V	0.3A	0.3A	

Remark: Using with a shunt-trip device (SHT) equipped breaker will improve tripping and phase protection.

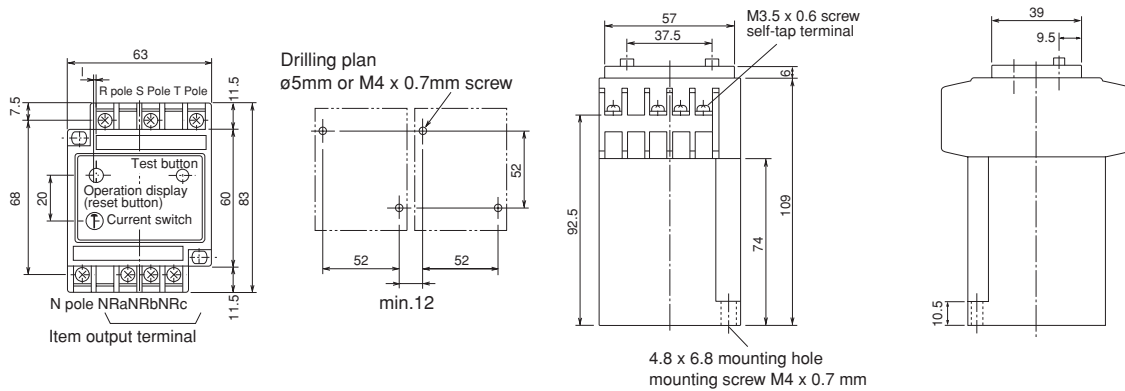

5. Accessories

External Accessories

1. F-type Operating Handle (Breaker Mount Type)



Attaches to Main Body of Circuit Breaker

- Circuit Breaker-mounted
Operating handle and control settings are mounted on the circuit breaker body.
- Panel door open state
Operating handle and control settings are attached on the breaker body.

- 1 Conforms to EN safety standards (EN 60204-1).
- 2 Provides a circuit disconnecting (isolating) function in combination with the breaker body.
- 3 IP54 protection rating (IEC 60529).
- 4 Compliant with UL489.

Door Lock Mechanism

- Standard products comply with reset open specifications.
- Performing the open (reset) operation is the only way to open the door.
- The panel door can also be opened when set in the ON or OFF position by turning the release screw.

Operation Lock

Standard products comply with OFF lock specifications. To set the operation lock in the OFF position: (For example, in the case of a padlock)

- 1 Turn the handle in the Reset direction to a position at which the marks on the lock plate and on the case are aligned.
- 2 Push the lock plate in.
- 3 While pushing the lock plate, return the handle to the OFF position.
- 4 Lock by passing the padlock through the hole in the center of the handle.

Three padlocks (35/40mm) which are commercially available can be installed. Even while the padlocks are installed, you can still open the panel door by turning the release screw.

Note: For 400~800AF, step ③ is not required.

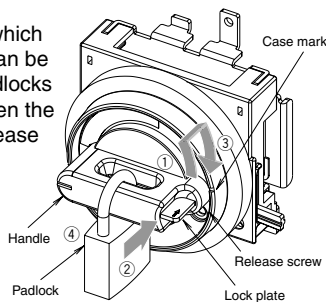

The ON/OFF lock specification enables the operation lock to be set even in the ON position. After pushing the lock plate with the handle in the ON position, attach the padlocks. Even in the case that the breaker has tripped after locking in the ON position, the operating handle displays the trip information.

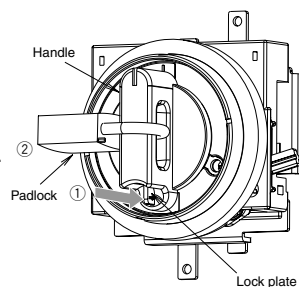

Note: For under 250AF, use a 35mm padlock (under 70g).
For under 400AF, use a 40mm padlock (under 100g).

Safety Device

The interlock lever prevents the breaker from being turned on while the panel door is open. When the breaker needs to be turned on while the door is open during checkup, turn the handle to the ON position while pushing the interlock lever in the direction of the arrow.

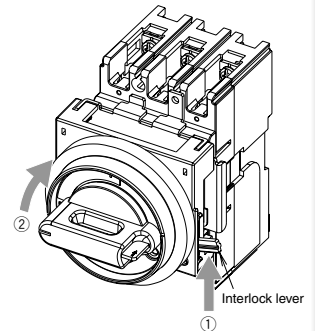

Made-to-order

Breaker mounting direction (Not including UL-listed products)

Even when a breaker is mounted horizontally, units can be made-to-order with the handle operation and ON/OFF indicators the same as standard vertical-mount models, and the same hole dimensions. Left- or right-facing power supply specifications are available for horizontal-mount models.

Door lock mechanism

OFF-Open specification..... The panel door can be opened in the OFF position.

Operation lock mechanism

ON/OFF-Lock specification.... Operation lock can be engaged in the ON or OFF position.

Sealing-off the Release Knob

Use the F-RCS release protection device, which is separately available, to prohibit opening the panel by operating the release knob.

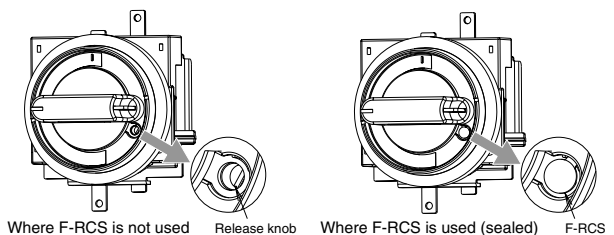

Note: For applicable lock devices, please refer to page 63.

5. Accessories

External Accessories

■ Outside Dimension Drawing

250A Frame or Smaller

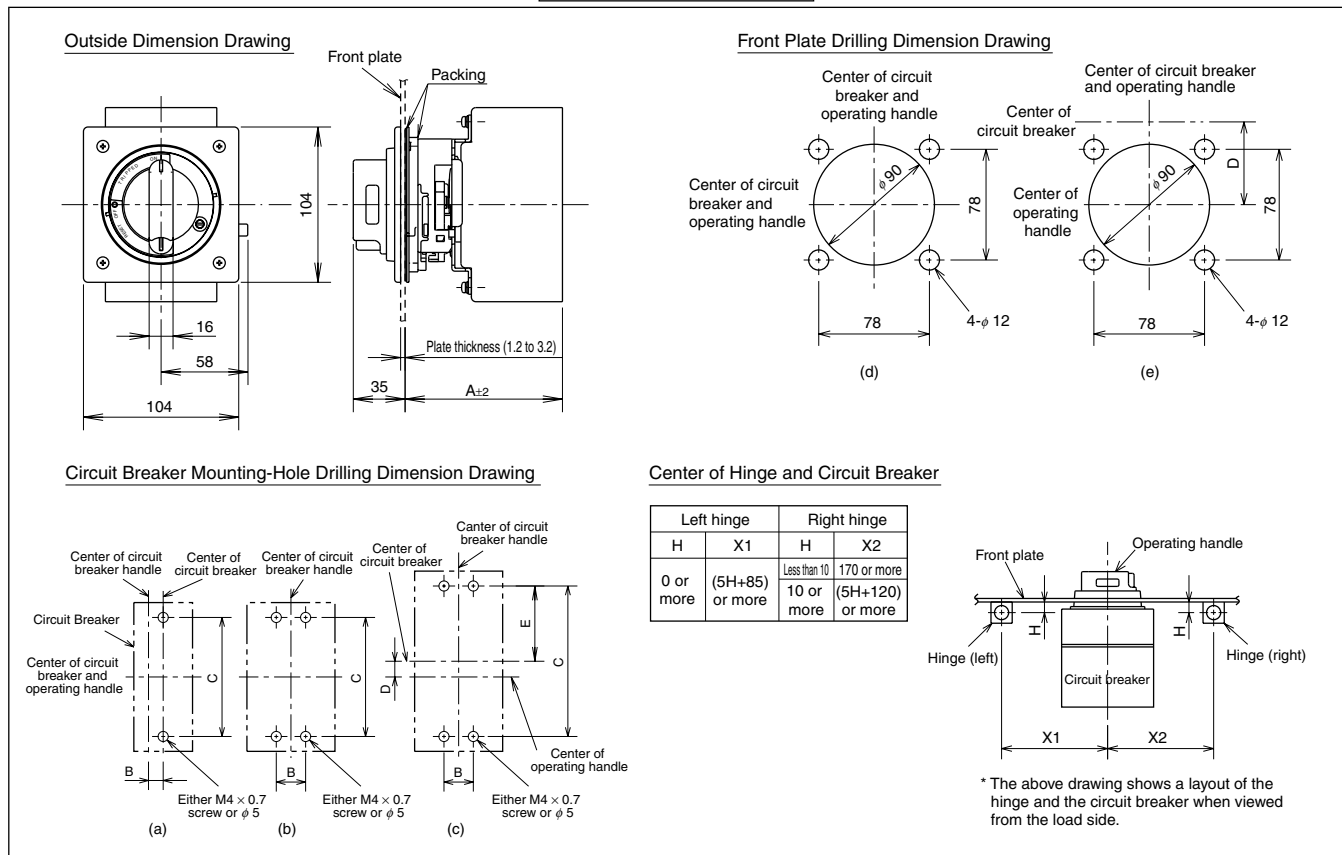

■ Summary of Dimensions

Table 5-19

Type names	Applicable models (*1)				Drilling plans	Dimensions (mm)				
	MCCB	Number of poles	ELCB/MCCB with ground fault protection	Number of poles		A	B	C	D	E
F-05S2, F-05SE2 (*4)	NF32-SW, NF63-CW, NF63-SW, NF63-HW, DSN32-SW, DSN63-CW, DSN63-SW	2	—	—	(a) (d)	105	12.5	111	—	—
F-05S, F-05SE	NF32-SW, NF63-CW, NF63-SW, NF63-HW, MB30-SW, MB50-CW, MB50-SW, DSN32-SW, DSN63-CW, DSN63-SW	3, 4	NV32-SW, NV63-CW, NV63-SW, NV63-HW	2, 3	(b) (d)		25			
F-1S2, F-1SE2 (*4)	NF125-CW, NF125-SW, DSN125-CW, DSN125-SW	2	—	—	(a) (d)		15			
F-1S, F-1SE	NF125-CW, NF125-SW, MB100-SW, DSN125-CW, DSN125-SW	3, 4	NV125-CW, NV125-SW, NV125-HW	3, 4	(b) (d)	30	172	30.5	86	
F-1U, F-1UE	—	—	NV125-RW	3	(c) (e)					
F-2S, F-2SE	NF250-CW, NF250-SW, NF250-HW, MB225-SW, DSN250-CW, DSN250-SW	2, 3, 4	NV250-CW, NV250-SW, NV250-HW, NV250-SEW, NV250-HEW	3, 4	(b) (d)	107	126	—	—	
F-2U, F-2UE	—	—	NV250-RW	3	(c) (e)		201			37.5
F-2SG, F-2SGE	NF125-SGW, NF125-HGW, NF160-SGW, NF160-HGW, NF250-SGW, NF250-HGW, DSN125-SGW, DSN160-SGW, DSN250-SGW	2, 3, 4	—	—	(b) (d)	125	126	—	—	
F-2UG, F-2UGE	NF125-RGW, NF125-UGW, NF250-RGW, NF250-UGW	2, 3, 4	—	—	(c) (e)		201			37.5
F-05SUL2	NF50-SWU	2	—	—	(a) (d)	105	12.5	111	—	—
F-05SUL	NF50-SWU	3	NV50-SWU	3	(b) (d)		25			
F-1SUL2	NF100-CWU, NF100-SWU	2	—	—	(a) (d)		15			
F-1SUL	NF100-CWU, NF100-SWU	3	NV100-SWU	3	(b) (d)		30			
F-2SUL	NF225-CWU	3	NV225-CWU	3	(b) (d)	107	35	126	—	—
F-2SGUL	NF-SFW, NF-SJW, NF-HJW	3	—	—	(c) (e)	125				

Note (*1) As for applicable models other than those mentioned above, please contact us.

(*2) Shows dimensions for front connection and rear connection types. For plug-in types, the reference surface changes.

(*3) 4-pole plug-in type is a special type. For details, please contact us.

(*4) When using with a terminal cover, please specify "F" at the end of terminal cover model name. (Special type terminal cover for operating handle with screws.)

■ Outside Dimension Drawing

400~800A Frame

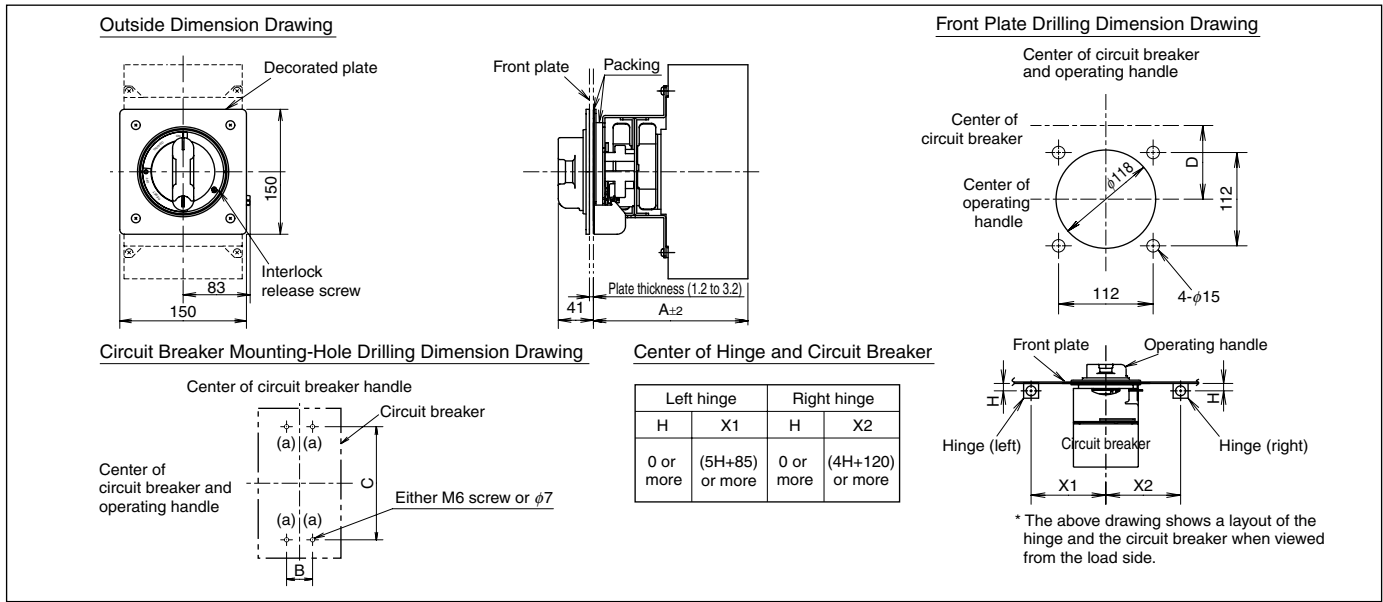

■ Summary of Dimensions

Table 5-20

Type names	Applicable models (*1)				Dimensions (mm)			
	MCCB	Number of poles	ELCB/MCCB with ground fault protection	Number of poles	A (*2)	B	C	D
F-4S, F-4SE	NF400-CW, NF400-SW, NF400-SEW, NF400-HEW, NF400-REW, DSN400-CW, DSN400-SW, NF630-CW, NF630-SW, NF630-SEW, NF630-HEW, NF630-REW, DSN630-CW, DSN630-SW	2, 3, 4	NV400-CW, NV400-SW, NV400-SEW, NV400-HEW, NV400-REW, NV630-CW, NV630-SW, NV630-SEW, NV630-HEW	3, 4	183	44	194	0
F-4U, F-4UE	NF400-UEW	3	—	—	280	44	234	20
F-8S, F-8SE	NF800-CEW, NF800-SDW, NF800-SEW, NF800-HEW, NF800-REW, DSN800-SW	2, 3, 4	NV800-SEW, NV800-HEW	3	183	70	243	0
F-8U, F-8UE	NF800-UEW, NF400-UEW(4P)	3, 4	—	—	280	70	290	23.5
F-4SUL	NF-SKW	3	NV-SKW	3	183	44	194	0
F-6SUL	NF-SLW	3	—	—	183	70	243	0

Note (*1) As for applicable models other than those mentioned above, please contact us.
(*2) Shows dimensions for front connection types. For rear connection and plug-in types, the reference surface changes.

■ Outside Dimension Drawing

Over 1000A Frame

● Appearance (Color N1.5)

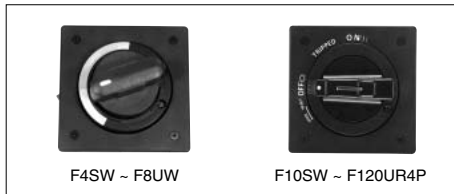

- Includes as standard a safety device which prevents breaker closing as long as the cover is open. (Specify if this safety feature is not required.)
- Indicates the tripping of the breaker even in ON-lock position—but only in cases when a single padlock (35mm, 40mm) is used.
- Degrees of protection (in accordance with IEC 60529): IP3X (IP5X with dustproof packing).

Table 5-21

Type	Breaker type	Number of poles	Fig			Dimensions (mm)						Mounting crews
			External dimensions	Drilling plan	(*)5	A	B	C	D	E	F	
F10SW (*7)	NF1000-SEW, NF1250-SEW/SDW, NF1600-SEW/SDW	2P, 3P	a	b	c	221	50	70	375	M8 screw or φ10	—	(X), (Y) Breaker mounting screws (4 pcs)
F10SW4P (*7)		4P										

Note (*1) Handles with NV in the product name include a test button.
(*2) Dustproof packing is also available as an option.
(*3) Other optional handles can also be mounted.
(*4) F4SW-F8UW are for isolation purposes. (Specify OFF lock only.)
(*5) The figures show the dimensions of the front connection. Some connection and plug-in breakers have a different reference surface for mounting purposes.
(*6) The standard type is equipped with a door-lock mechanism that allows the door to be opened only when OFF operation is carried out.
(*7) In case of reset opened type use.

Center of Hinge and Circuit Breaker

Left hinge		Right hinge	
H	X1	H	X2
0 or more	(8H+150) or more	0 or more	(4H+120) or more

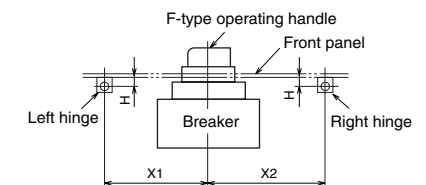

The figure above shows the relationship between the hinge and breaker viewed from the load side of the breaker.

5. Accessories

External Accessories

2. V-type Operating Handle (Door Mount Type)



Operating handle attached to the panel door and control settings attached to the breaker body

- The control settings are mounted to the circuit breaker body and the operating handle is mounted on the panel door.
- Panel door open state
The operating handle is built into the door and the control settings are built into the circuit breaker body.

- 1 Conforms to EN safety standards (EN 60204-1).
- 2 Provides a circuit disconnecting (isolating) function in combination with the breaker body.
- 3 IP54 rating (IEC 60529).
- 4 Can be mounted on 2-pole breakers.
- 5 Operating handle for the 3-pole breakers can also be used with the 4-pole breaker.

● Door Lock Mechanism

The panel door can be opened in the OFF position. In the ON and TRIP position, the panel door is locked so that it cannot be opened. However, you can still open the panel door in the ON and TRIP position by pushing the release tab in the direction of the arrow using a tool.

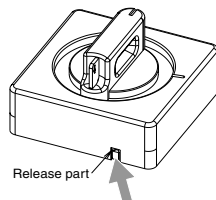

● Adjustable Type

By mounting an adjustment unit V-AD3S or V-AD3L, separately available parts, to the built-in control settings, you can adjust the height between the breaker installation face and the panel door. Cut the shaft of the adjustment unit to fit the height.

Note: This cannot be used for 2-pole breakers. If it is used, it may cause the position display to malfunction.

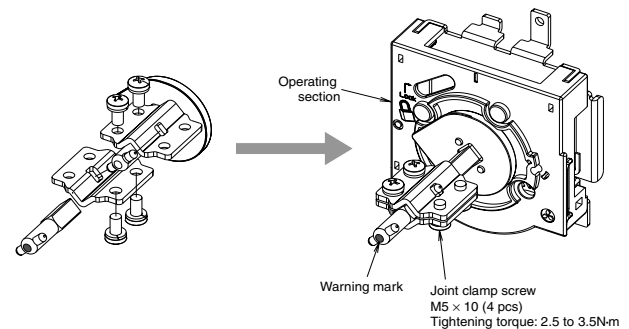

● Operation Lock

This complies with OFF lock specifications. To set the operation lock in the OFF position: (For example, in the case of a padlock)

- 1 Turn the handle in the Reset direction to a position at which the marks on the lock plate and on the case are aligned.
- 2 Push the lock plate in.
- 3 While pushing the lock plate, return the handle to the OFF position.
- 4 Lock by passing the padlock through the hole in the center of the handle.

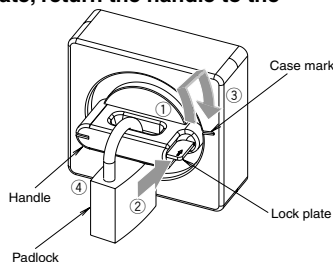

Three padlocks (35/40mm) which are commercially available can be installed.

Note: For 400~800AF, step ③ is not required.

● Operation Lock Devices

(1) Padlock

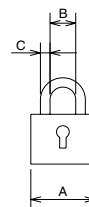

Padlock Dimensions

Use commercially available padlocks. (mm)

Applicable model	A (Nominal size)	B	C
All models	35	19	5
	40	22 or 23	5.5

Dimension C: Maximum 8mm.

(2) Lockout Devices (Scissors Lock)

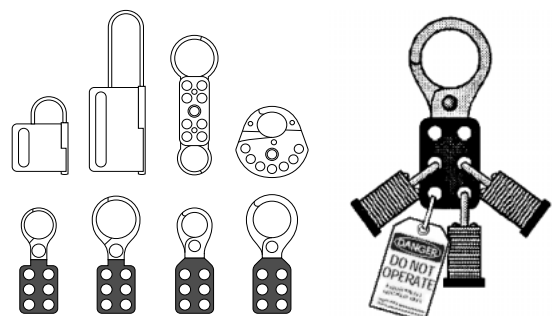

● Operation Lock While Panel Door Is Open

During checkup, etc. while the panel door is open, you can use the operation lock to prevent the breaker from being turned on by accident. Lock by passing a padlock through the lock hole of the operating section of the operating handle.

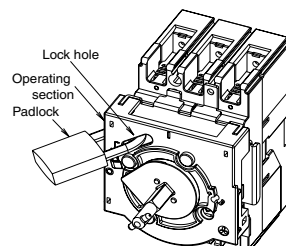

■ Outside Dimension Drawing

250A Frame or Smaller

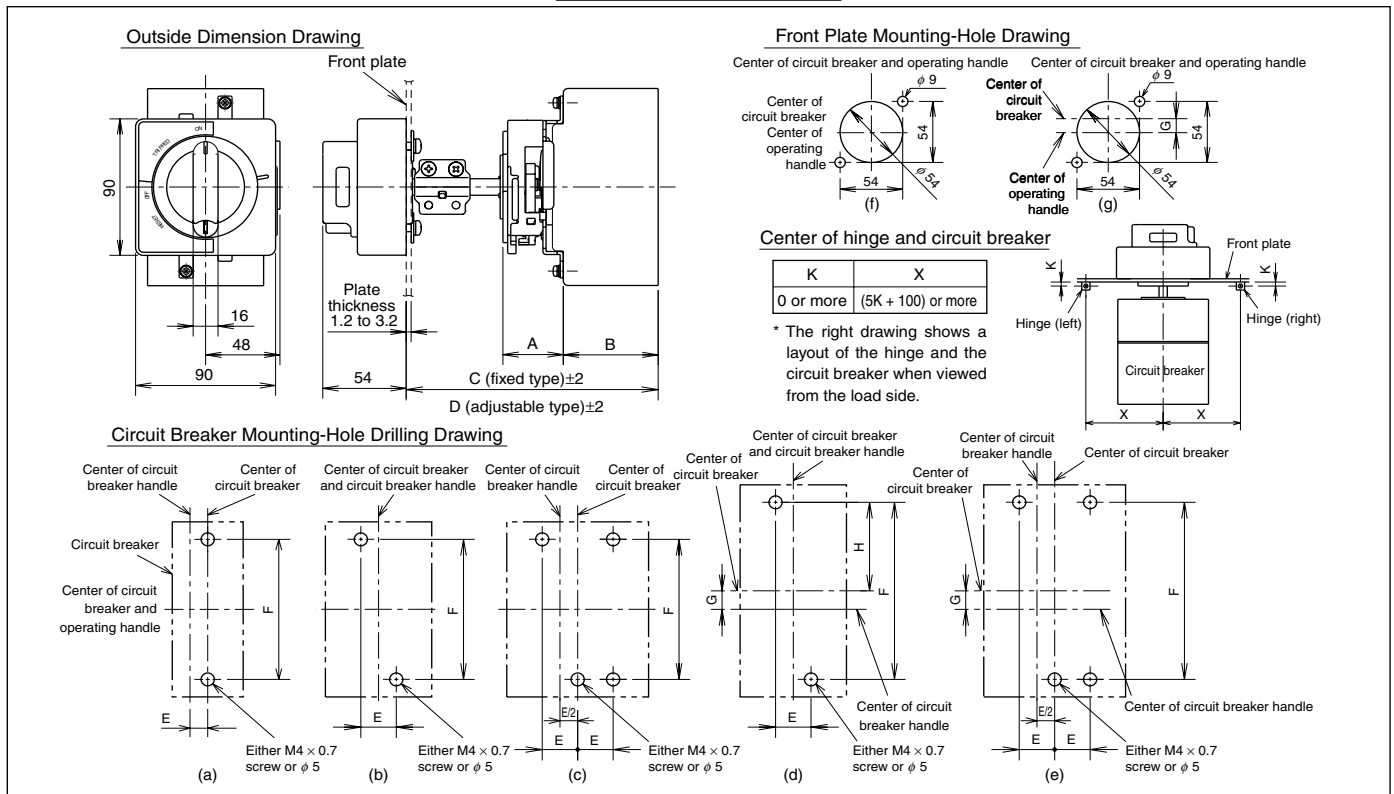

■ Summary of Dimensions

Table 5-22

Type names	Applicable models (*1)				Drilling plans	Dimension (mm)																
	MCCB		ELCB/MCCB with ground fault protection			A	B	Fixed type		Adjustable type (*2)		E	F	G	H							
		Number of poles		Number of poles				C	D (min.)	D (max.)												
V-05S2, V-05SE2 (*3)	NF32-SW, NF63-CW, NF63-SW, NF63-HW, DSN32-SW, DSN63-CW, DSN63-SW	2	—	—	(a) (f)	39	61	125	—	—	12.5	111	—	—								
V-05S, V-05SE	NF32-SW, NF63-CW, NF63-SW, NF63-HW, MB30-SW, MB50-CW, MB50-SW, DSN32-SW, DSN63-CW, DSN63-SW	3	NV32-SW, NV63-CW, NV63-SW, NV63-HW	2, 3	(b) (f)				162	300	25											
V-1S2, V-1SE2 (*3)	NF125-CW, NF125-SW, DSN125-CW, DSN125-SW	2	—	—	(a) (f)				—	—	15											
V-1S, V-1SE	NF125-CW, NF125-SW, MB100-SW, DSN125-CW, DSN125-SW	3	NV125-CW, NV125-SW, NV125-HW	3	(b) (f)				30	172	30.5				86							
		4	—	—	(c) (f)																	
		2, 3	—	—	(b) (f)																	
V-1U, V-1UE	—	—	NV125-RW	3	(d) (g)				162	300	35											
															4	—	—	(c) (f)				
V-2S, V-2SE	NF250-CW, NF250-SW, NF250-HW, MB225-SW, DSN250-CW, DSN250-SW	2, 3	NV250-CW, NV250-SW, NV250-HW, NV250-SEW, NV250-HEW	3	(b) (f)				41	79	143				180	318	126	—	—			
V-2U, V-2UE	—	—	NV250-RW	3	(d) (g)															201	37.5	100.5
						4	—	—				(c) (f)										
V-2SG, V-2SGE	NF125-SGW, NF125-HGW, NF160-SGW, NF160-HGW, NF250-SGW, NF250-HGW, DSN125-SGW, DSN160-SGW, DSN250-SGW	2, 3	—	—	(b) (f)																	
		4	—	—	(c) (f)																	
		2, 3	—	—	(d) (g)																	
V-2UG, V-2UGE	NF125-RGW, NF125-UGW, NF250-RGW, NF250-UGW	4	—	—	(e) (g)	201	37.5	100.5														
V-05SUL2	NF50-SWU	2	—	—	(a) (f)	39	61	125				—	—	12.5						111	—	—
V-05SUL		3	NV50-SWU	3	(b) (f)							162	300	25								
V-1SUL2		2	—	—	(a) (f)							—	—	15								
V-1SUL		3	NV100-SWU	3	(b) (f)				—	—	30											
V-2SUL	NF225-CWU	3	NV225-CWU	3	(b) (f)	162	300	30														
V-2SGUL	NF-SFW, NF-SJW, NF-HJW	3	—	—	(b) (f)	41	79	143	180	318	35	126	—	—								

Note (*1) As for applicable models other than those mentioned above, please contact us.

(*2) As for the adjustable type, the dimensions shown above are those when the adjustment unit V-AD3S separately available is mounted.

(*3) When using with a terminal cover, please specify "F" at the end of terminal cover model name. (Special type terminal cover for operating handle with screws.)

Remark: 1. Shows dimensions for front connection and rear connection types. For plug-in types, please contact us.

5. Accessories

External Accessories

■ Outside Dimension Drawing

400~800A Frame

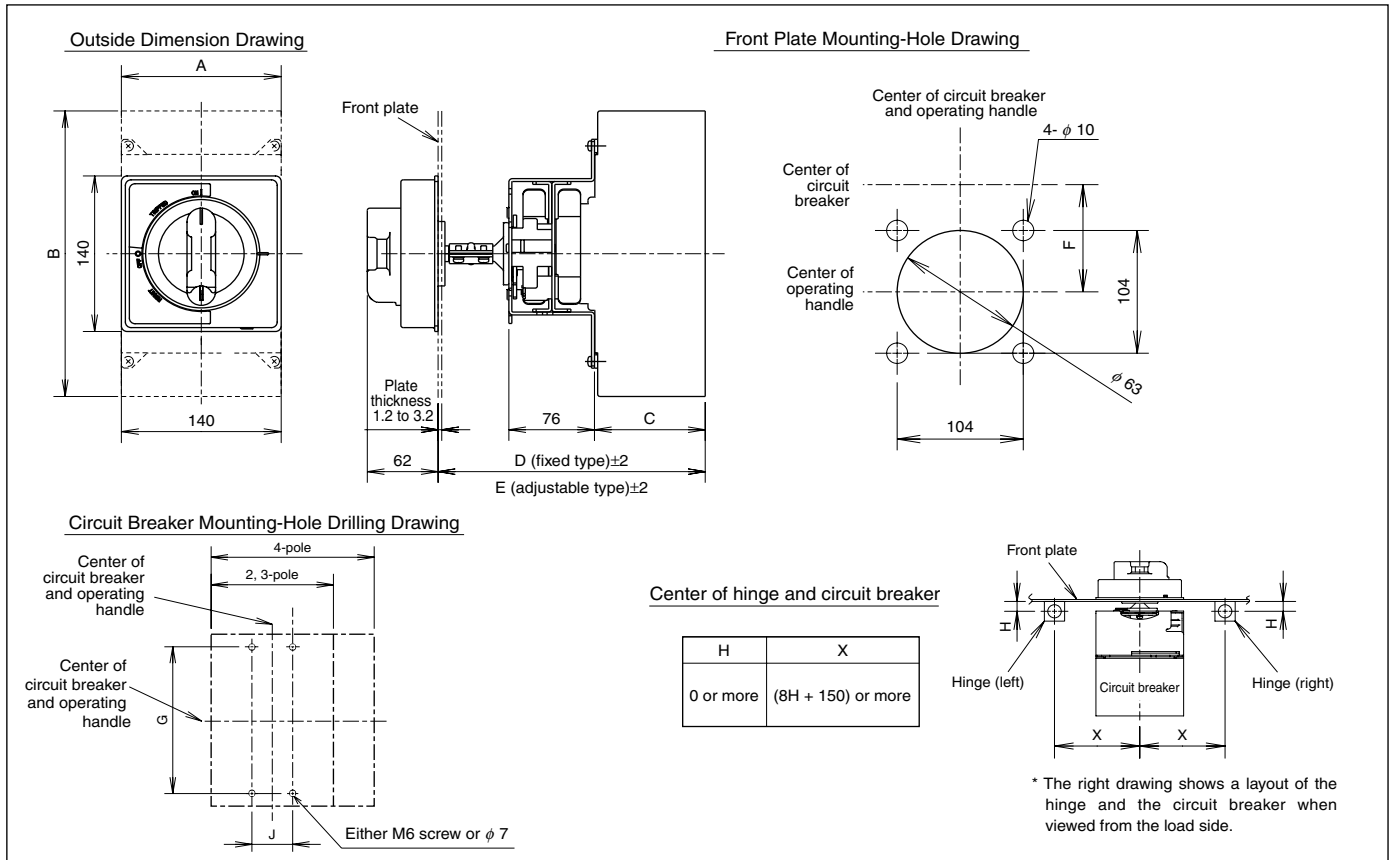

■ Summary of Dimensions

Table 5-23

Type names	Applicable models (*1)				Dimension (mm)								
	MCCB	Number of poles	ELCB/MCCB with ground fault protection	Number of poles	A	B	C	Adjustable type (*2)			F	G	J
								Fixed type D	E (min.)	E (max.)			
V-4S, V-4SE	NF400-CW, NF400-SW, NF400-SEW, NF400-HEW, NF400-REW, DSN400-CW, DSN400-SW, NF630-CW, NF630-SW, NF630-SEW, NF630-HEW, NF630-REW, DSN630-CW, DSN630-SW	2, 3, 4	NV400-CW, NV400-SW, NV400-SEW, NV400-HEW, NV400-REW, NV400-NCW, NV630-CW, NV630-SW, NV630-SEW, NV630-HEW	3, 4	140	257	97	191	233	300	0	194	44
V-8S, V-8SE	NF800-CW, NF800-SW, NF800-SEW, NF800-HEW, NF800-REW, DSN800-SW	2, 3, 4	NV800-SEW, NV800-HEW	3	210	275	97	191	233	300	0	243	70
V-4SUL	NF-SKW	3	NV-SKW	3	140	257	97	191	233	300	0	194	44
V-6SUL	NF-SLW	3	—	—	210	275	97	191	233	300	0	243	70

Note (*1) As for applicable models other than those mentioned above, please contact us.

(*2) As for the adjustable type, the dimensions shown above are those when the adjustment unit V-AD3L separately available is mounted.

Remark: 1. Shows dimensions for front connection types. For rear connection types, the reference surface changes. For plug-in types, please contact us.

■ Appearance of 400~800A Frame



In the circumstances where safety of machinery is emphasized, this operating handle is effective for the emergency stop use in accordance to provisions of IEC 60204-1, EN 60204-1, NFPA79, and JIS B 9960-1. The operating handle is colored in accordance with the applicable standard (handle in red and the surrounding part in yellow). The type name consists of “E” added to the type name of the standard operating handle.

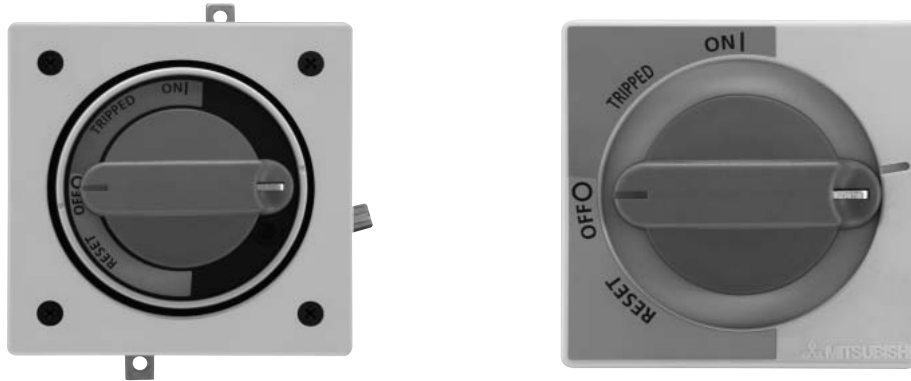

REFERENCE Requirements Regarding Operating Handles Covered by Standards Relating to Machinery

* Major requirements regarding operating handles are excerpted below from the standards relating to machinery.

Standard	Details of Requirement	Standard	Details of Requirement
IEC 60204-1 EN 60204-1 (Safety of Machinery, Electric Equipment of Machines - Part 1: Specifications for General Requirements)	<ul style="list-style-type: none"> • “0” and “I” should be clearly identified. • The operating direction should conform to IEC 60447/EN 60447. → Clockwise direction • There should be no OFF indication until the contact is fully opened. • Disconnecting (isolating) function should be provided. • The handle should be colored in either black or gray. (Except some of those for emergency stop use.) • Measures to enable to lock in the OFF position should be provided. • The enclosure can be opened while live parts are disconnected. → Interlock with the door • Interlock can be released by a qualified person using a tool when the conditions (a) and (b) below are satisfied: → Release operation <ul style="list-style-type: none"> (a) While interlock is released, turning OFF and OFF lock are always enabled. (b) When the door is closed, the door lock is automatically reset. • The enclosure should conform to the protection grade of, at least, IP22. • The actuator of the emergency stop device should be red in color. The surrounding part where the actuator is installed should be yellow in color. 	NFPA79 (Electrical Standard for Industrial Machinery)	<ul style="list-style-type: none"> • Measures to enable locking only in the OFF position regardless of door position. → Prohibition of ON lock • Operation should be enabled without any tool regardless of door position. • Either OFF state or ON state should be clearly indicated. • Interlock should be provided to prevent the door from being opened without disconnecting power supply. • The handle function should not be lost when the door position is open. • A qualified person can make an access without disconnecting power supply. → Release operation • A qualified person can release interlock by using a tool. → Release operation • When the door is closed, the door lock is automatically reset. • While the door is open, it cannot be turned ON unless interlock is intentionally released.
		UL508A (Industrial Control Panel)	<ul style="list-style-type: none"> • Either OFF state or ON state should be clearly indicated. • Unless power supply is cut off, the door cannot be opened. (Interlock) • Interlock can be released by use of a tool. → Release operation • Measures are provided to prevent recovery of power supply while the door is open. • Locking should be enabled in either the ON or OFF position. • When the door is closed, the door lock is automatically reset.

5. Accessories

External Accessories

■ Operating Handles

The basic type (standard) for the F-type operating handle includes OFF-lock/reset open/mounting on power source. When ordering specifications other than those mentioned above, designate the specifications in symbols together with the basic type name. The V-type operating handle is available only in the basic type (standard).

Basic type name		Required specifications										
		Operation lock	Door open	Installation direction								
F-05S2		LF	DR	Y								
F-type	General products	For general use	For emergency stop use	<table border="1"> <thead> <tr> <th>Symbol</th> <th>Specifications</th> </tr> </thead> <tbody> <tr> <td>Blank</td> <td>Power supply (upper)</td> </tr> <tr> <td>Y</td> <td>Power supply (left)</td> </tr> <tr> <td>Z</td> <td>Power supply (right)</td> </tr> </tbody> </table> <p>Note: As for the UL listed products, only the specification of "mounting on power source" is available.</p>	Symbol	Specifications	Blank	Power supply (upper)	Y	Power supply (left)	Z	Power supply (right)
		Symbol	Specifications									
	Blank	Power supply (upper)										
	Y	Power supply (left)										
Z	Power supply (right)											
For general use	For emergency stop use	<table border="1"> <thead> <tr> <th>Symbol</th> <th>Specifications</th> </tr> </thead> <tbody> <tr> <td>LF</td> <td>OFF-lock</td> </tr> <tr> <td>LN</td> <td>ON/OFF lock</td> </tr> </tbody> </table>	Symbol	Specifications	LF	OFF-lock	LN	ON/OFF lock				
Symbol	Specifications											
LF	OFF-lock											
LN	ON/OFF lock											
F-05S2 F-05S F-1S2 F-1S F-1U F-2S F-2SG F-2UG F-4S F-4U F-8S F-8U	F-05SE2 F-05SE F-1SE2 F-1SE F-1UE F-2SE F-2SGE F-2UGE F-4SE F-4UE F-8SE F-8UE	<table border="1"> <thead> <tr> <th>Symbol</th> <th>Specifications</th> </tr> </thead> <tbody> <tr> <td>DR</td> <td>Reset open</td> </tr> <tr> <td>DF</td> <td>OFF open</td> </tr> </tbody> </table>	Symbol	Specifications	DR	Reset open	DF	OFF open				
Symbol	Specifications											
DR	Reset open											
DF	OFF open											
UL listed product												
V-type	General products	For general use	For emergency stop use	<table border="1"> <thead> <tr> <th>Symbol</th> <th>Specifications</th> </tr> </thead> <tbody> <tr> <td>Blank</td> <td>Power supply (upper)</td> </tr> <tr> <td>Y</td> <td>Power supply (left)</td> </tr> <tr> <td>Z</td> <td>Power supply (right)</td> </tr> </tbody> </table> <p>Note: As for the UL listed products, only the specification of "mounting on power source" is available.</p>	Symbol	Specifications	Blank	Power supply (upper)	Y	Power supply (left)	Z	Power supply (right)
		Symbol	Specifications									
	Blank	Power supply (upper)										
	Y	Power supply (left)										
Z	Power supply (right)											
For general use	For emergency stop use	<table border="1"> <thead> <tr> <th>Symbol</th> <th>Specifications</th> </tr> </thead> <tbody> <tr> <td>LF</td> <td>OFF-lock</td> </tr> <tr> <td>LN</td> <td>ON/OFF lock</td> </tr> </tbody> </table>	Symbol	Specifications	LF	OFF-lock	LN	ON/OFF lock				
Symbol	Specifications											
LF	OFF-lock											
LN	ON/OFF lock											
V-05S2 V-05S V-1S2 V-1S V-1U V-2S V-2SG V-2UG V-4S V-8S	V-05SE2 V-05SE V-1SE2 V-1SE V-1UE V-2SE V-2SGE V-2UGE V-4SE V-8SE	<table border="1"> <thead> <tr> <th>Symbol</th> <th>Specifications</th> </tr> </thead> <tbody> <tr> <td>DR</td> <td>Reset open</td> </tr> <tr> <td>DF</td> <td>OFF open</td> </tr> </tbody> </table>	Symbol	Specifications	DR	Reset open	DF	OFF open				
Symbol	Specifications											
DR	Reset open											
DF	OFF open											
UL listed product												

■ Adjustment Unit (for V-type operating handle)

Please specify the type name and the necessary quantity. One order unit includes 1 piece.

	Type name
Under 250AF	V-AD3S
400-800AF	V-AD3L

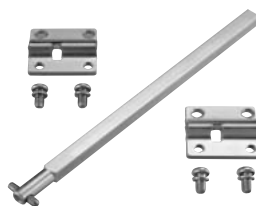

■ Release Protection (for F-type operating handle)

Please specify the type name and the necessary quantity. One order unit includes 10 pieces.

Type name
F-RCS



3. S-type Operating Handle

● Appearance (Color N1.5)



- The handle can be locked at either ON or OFF position. (Three padlocks (35mm, 40mm) can be installed. Off-position lock only specifications are also acceptable.)
- Degrees of protection (IEC 60529) IP5X

Remark: 1. Trip action can be displayed when the circuit breaker trips even if ON-position lock is selected (only in the case of a single padlock (35 mm)).

● Outside Dimension Diagram

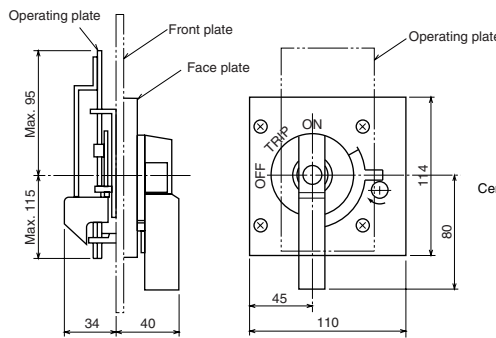

● Front Plate Drilling Dimension Diagram

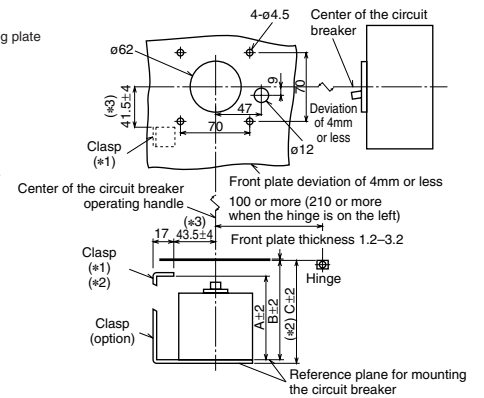

Table 5-24: Summary of Dimensions

Type name	Applicable models	Dimensions (mm)		
		A (*4)	B (*4)	C (*4)
S05SW	NF32-SW, NF63-CW/SW/HW, NV32-SW, NV63-CW/SW/HW, MB30-SW, MB50-CW/SW	87	102	104.5
S1SW	NF125-CW/SW/HW, NV125-CW/SW/HW, MB100-SW, NV125-RW (*5)			
S2SW	NF160-SW/HW, NF250-CW/SW/HW, NV250-CW/SW/HW, NV250-SEW/HEW, MB225-SW, NV250-RW (*5)	95	110	112.5
S2GSW	NF125-SGW/HGW, NF160-SGW/HGW, NF250-SGW/HGW	113	128	130.5

Note (*1) The clasps are not supplied standardly, and should be prepared by users. Details on dimensions and others will be available upon request.

Remark: 1. Reset open-type

2. These are not suitable for isolation.

(*2) When the optional clasp is used.

(*3) The tolerance from the center of $\phi 62$ is shown.

(*4) The dimensions of the front-face type are shown. Some of the back-face and plug-in types have a different reference plane for mounting the circuit breaker.

(*5) The front plate drilling dimensions for the U series differ from those shown above. Please consult us for their details.

● Appearance (Color N1.5)

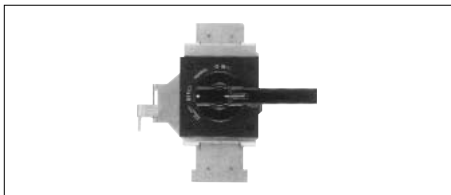

- Indicates the tripping of the breaker even in ON-lock position--but only in cases when a single padlock (35mm or 40mm) is used.
- Degrees of protection (in accordance with IEC 60529): IP5X.

● External dimensions

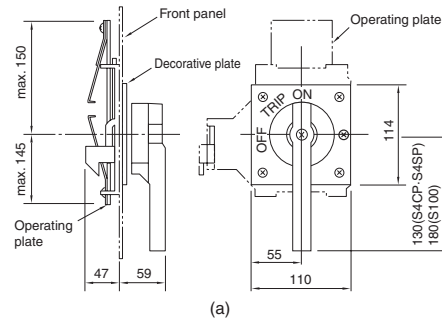

● Drilling plan

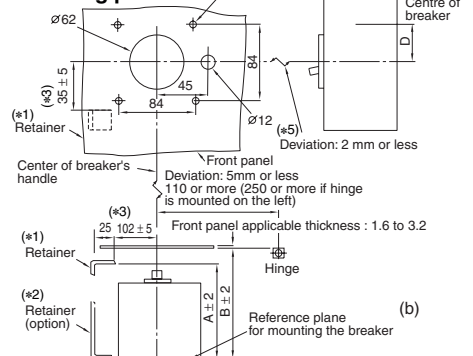

Table 5-25

Type	Breaker type	Fig	Dimensions (mm)				
			External dimensions	Drilling plan	A (*4)	B (*4)	C (*4)
S4CW (*5)	NF400-CW, NV400-CW	a	b	140	156	—	0
S4SW (*5)	NF400-SW/SEW/HEW/REW, NV400-SW/SEW/HEW/REW, NF630-CW/SW/SEW/HEW/REW, NV630-CW/SW/SEW/HEW, NF800-CEW/SDW/SEW/HEW/REW, NV800-SEW/HEW	a	b	162	178	—	0
	NF400-U EW (3P)			259	275	—	20
	NF400-U EW (4P), NF800-U EW			259	275	—	23.5
S10SW	NF1000-SEW, NF1250-SEW/SDW, NF1600-SEW/SDW	a	b	199	215	—	0

Note (*1) Retainers are not included. They must be provided by the customer.

(*2) When using optional retainer.

(*3) Shows the tolerance for the distance from the center of a 62mm dia. hole.

(*4) The figures show the front-connection dimensions. Some rear-connection and plug-in breakers have a different reference surface for mounting purposes.

(*5) S4CW and S4SW are for isolation purposes. (Specify OFF lock only.) The tolerance is less than 5mm. It does not conform to isolation purposes, however, if the deviation is more than 2mm.

Remark: 1. Reset open-type

● Surface plate interlocking fastening (separately available)

Operation handle series	Type	Breaker type		Dimensions (mm)		Drilling diagram and referential diagram
		MCCB	ELCB	A	B	
S-type	TG-S05SW	NF32-SW, NF63-CW/SW/HW, MB30-SW, MB50-CW/SW, NF125-CW/SW/HW, MB100-SW	NV32-SW, NV63-CW/SW/HW	67	119	
	TG-S1UW (*1)	NF125-RGW/UGW	NV125-RW			
	TG-S2SW (*1)	NF160-SW/HW, NF250-CW/SW/HW, NF250-SEW/HEW, MB225-SW	NV250-CW/SW/HW, NV250-SEW/HEW			
	TG-S2UW (*1)	NF250-RGW/UGW	NV250-RW			
	TG-S2GSW (*1)	NF125-SGW/HGW, NF160-SGW/HGW, NF250-SGW/HGW, NF-SFW, NF-SJW, NF-HJW	—			
	TG-S4CW	NF400-CW	NV400-CW			
	TG-S4SW	NF400-SW/SEW/HEW/REW, NF630-CW/SW/SEW/HEW/REW, NF800-CEW/SDW/SEW/HEW/REW	NV400-SW/SEW/HEW/REW, NV630-CW/SW/SEW/HEW, NV800-SEW/HEW			
	TG-S4UW	NF400-U EW (3P), NF400-U EW (4P), NF800-U EW	—			
	TG-S10	NF1000-SEW, NF1250-SEW/SDW, NF1600-SEW/SDW	—			

Remark: 1. The clamp for surface plate interlock fastener is common to 2P, 3P and 4P.

Note (*1) The terminal cover cannot be installed.

5. Accessories

External Accessories

Ordering information

V	-	1	S	UL	E	2
1)		2)	3)	4)	5)	6)

- 1) V : V-type Operating handle
- 2) 1 : Frame size of breaker
- 05..... NF32-SW, NF63-CW/SW/HW, MB30-SW, MB50-CW/SW, DSN32-SW, DSN63-CW/SW, NV32-SW, NV63-CW/SW/HW
 - 1..... NF125-CW/SW/HW, NV125-CW/SW/HW, MB100-SW, DSN125-CW/SW, NV125-RW
 - 2..... NF160-SW/HW, NF250-CW/SW/HW, MB225-SW, NV250-CW/SW/HW/SEW/HEW, DSN250-CW/SW, NV250-RW, NF125-SGW/HGW, NF160-SGW/HGW, NF250-SGW/HGW, DSN125-SGW, DSN160-SGW, DSN250-SGW, NF125-RGW/UGW, NF250-RGW/UGW
 - 4..... NF400-CW/SW/SEW/HEW/REW, DSN400-CW/SW, NV400-CW/SW/SEW/HEW/REW, NF630-CW/SW/SEW/HEW/REW, DSN630-CW/SW, NV630-CW/SW/SEW/HEW
 - 8..... NF800-CEW/SDW/SEW/HEW/REW, NV800-SEW/HEW, DSN800-CW/SW
- 3) S : Series name
- S indicate WSS C, S and H series
 - U indicate WSS RW/UEW/RGW/UGW
 - SG indicate SGW/HGW
- 4) UL : Type of breaker
- Blank..... General product
 - UL..... UL Listed product
- 5) E : For emergency
- Blank..... For general
 - E..... For emergency
- 6) 2 : Number of poles
- Blank..... 3 pole and 4 pole
 - 2..... 2 pole

S	1	SW	A
1)	2)	3)	4)

- 1) S : Operating handle type
- 2) 1 : Frame size of breaker
- 05..... NF32-SW, NF63-CW/SW/HW, MB30-SW, MB50-CW/SW, DSN32-SW, DSN63-CW/SW, NV32-SW, NV63-CW/SW/HW
 - 1..... NF125-CW/SW/HW, NV125-CW/SW/HW, MB100-SW, DSN125-CW/SW, NV125-RW
 - 2..... NF160-SW/HW, NF250-CW/SW/HW, MB225-SW, NV250-CW/SW/HW/SEW/HEW, DSN250-CW/SW, NV250-RW
 - 2G.... NF125-SGW/HGW, NF160-SGW/HGW, NF250-SGW/HGW, DSN125-SGW, DSN160-SGW, DSN250-SGW
 - 4..... NF400-CW/SW/SEW/HEW/REW, DSN400-CW/SW, NV400-CW/SW/SEW/HEW/REW, NF400-UEW, NF630-CW/SW/SEW/HEW/REW, DSN630-CW/SW, DSN800-CW/SW, NF800-CEW/SDW/SEW/HEW/REW, NV630-CW/SW/SEW/HEW, NV800-SEW/HEW, NF400-UEW(4P), NF630-UEW, NF800-UEW
- 3) SW : Series name
- SW indicate WSS C, S and H series
 - CW indicate WSS 400A frame C series
- 4) A : Handle lock position
- Blank..... ON/OFF position lock
 - A..... OFF position lock only

S	10	SW
1)	2)	3)

- 1) S : Operating handle type
- 2) 10 : Frame size of breaker
- 10..... NF1000-SS/SSD, NF1250-SS/SSD, NF1600-SS/SSD, NF1250-UR
- 3) SW : Series name
- SW indicate WSS

F	-	1	S	UL	E	2	LF	DR	Y
1)		2)	3)	4)	5)	6)	7)	8)	9)

- 1) F : F-type Operating handle
- 2) 1 : Frame size of breaker
- 05..... NF32-SW, NF63-CW/SW/HW, MB30-SW, MB50-CW/SW, DSN32-SW, DSN63-CW/SW, NV32-SW, NV63-CW/SW/HW
 - 1..... NF125-CW/SW/HW, NV125-CW/SW/HW, MB100-SW, DSN125-CW/SW, NV125-RW
 - 2..... NF160-SW/HW, NF250-CW/SW/HW, MB225-SW, NV250-CW/SW/HW/SEW/HEW, DSN250-CW/SW, NV250-RW, NF125-SGW/HGW, NF160-SGW/HGW, NF250-SGW/HGW, DSN125-SGW, DSN160-SGW, DSN250-SGW, NF125-RGW/UGW, NF250-RGW/UGW
 - 4..... NF400-CW/SW/SEW/HEW/REW, DSN400-CW/SW, NV400-CW/SW/SEW/HEW/REW, NF400-UEW, NF630-CW/SW/SEW/HEW/REW, DSN630-CW/SW, NV630-CW/SW/SEW/HEW
 - 8..... NF800-CEW/SDW/SEW/HEW/REW, NV800-SEW/HEW, NF400-UEW(4P), NF800-UEW, DSN800-CW/SW
- 3) S : Series name
- S indicate WSS C, S and H series
 - U indicate WSS RW/UEW/RGW/UGW
 - SG indicate SGW/HGW
- 4) UL : Type of breaker
- Blank..... General product
 - UL..... UL Listed product
- 5) E : For emergency
- Blank..... For general
 - E..... For emergency
- 6) 2 : Number of poles
- Blank..... 3 pole and 4 pole
 - 2..... 2 pole
- 7) A : Handle lock position
- LN..... ON/OFF position lock
 - LF..... OFF position lock only
- 8) R : Door open position
- DF..... OFF position open
 - DR..... RESET position open
- 9) Y : Mounting direction
- Blank..... Vertically type (ON side of breaker is upper)
 - Y..... Horizontally type (ON side of breaker is left)
 - Z..... Horizontally type (ON side of breaker is right)

F	10	SW	4P
1)	2)	3)	4)

- 1) F : Operating handle type
- 2) 10 : Frame size of breaker
- 10..... NF1000-SEW, NF1250-SEW/SDW, NF1600-SEW/SDW
- 3) SW : Series name
- SW indicate WSS
- 4) 4P : Number of poles
- Blank..... 2 pole and 3 pole
 - 4P..... 4 pole

4. Terminal Cover

Table 5-26

Breaker type		Large terminal cover (TC-L)	Small terminal cover (TC-S)	Transparent terminal cover (TTC)	Rear terminal cover (BTC)	Plug-in terminal cover (PTC)
NF30-CS, MB30-CS	2P					—
NF30-CS, NV30-CS, MB30-CS	3P					—
NF32-SW, NF63-CW/SW/HW	2P	TCL-05SW2W (*1) (50×65.5×25)	TCS-05SW2W (*1) (50×65.5×5)	TTC-05SW2 (*1) (50×65.5×25)	BTC-05SW2W (50×65.5×5)	PTC-05SW2W (50×65.5×6.5)
NF32-SW, NF63-CW/SW/HW NV32-SW, NV63-CW/SW/HW, MB30-SW MB50-CW/SW	3P	TCL-05SW3W (*2) (75×65.5×25)	TCS-05SW3W (*2) (75×65.5×5)	TTC-05SW3 (*2) (75×65.5×25)	BTC-05SW3W (75×65.5×5)	PTC-05SW3W (75×65.5×6.5)
NF125-CW/SW/HW	2P	TCL-1SW2W (*1) (60×65.5×40)	TCS-1SW2W (*1) (60×65.5×6.5)	TTC-1SW2 (*1) (60×65.5×40)	BTC-1SW2W (60×65.5×6.5)	PTC-1SW2W (60×65.5×6.5)
NF125-CW/SW/HW, NV125-CW/SW/HW, NV125-RW, MB100-SW	3P	TCL-1SW3W (*2) (90×65.5×40)	TCS-1SW3W (*2) (90×65.5×6.5)	TTC-1SW3 (*2) (90×65.5×40)	BTC-1SW3W (90×65.5×6.5)	PTC-1SW3W (90×65.5×6.5)
NF160-SW/HW, NF250-CW/SW/HW, NV250-CW/SW/HW, NV250-SEW/HEW, NV250-RW MB225-SW	2P 3P	TCL-2SW3W (*2) (105×65.5×40)	TCS-2SW3W (*2) (105×65.5×6.5)	TTC-2SW3 (*2) (105×65.5×40)	BTC-2SW3W (105×65.5×6.5)	PTC-2SW3W (105×65.5×6.5)
NF125-SGW/HGW/RGW/UGW, NF160-SGW/HGW NF250-SGW/HGW/RGW/UGW	2P 3P	TCL-2GSW3W (105×84×40)	TCS-2GSW3W (105×84×6.5)	TTC-2GSW3 (105×84×40)	BTC-2GSW3W (105×84×6.5)	PTC-2GSW3W (105×84×6.5)

Note (*1) Attach the letter "F" to the end of model designation for models with F-type operating handle. (Those are F-type operating-handle dedicated models, and screws are used for fixing.)

(*2) An F-type operating handle can be installed.

Remark: 1. Parenthesized numbers denote the outside dimensions (A×B×C in mm).
2. The terminal cover for a four-pole model can be produced upon request.

Table 5-27

Breaker type		Large terminal cover (TC-L)	Transparent terminal cover (TTC)	Rear terminal cover (BTC)	Plug-in terminal cover (PTC)
NF400-CW/SW/SEW/HEW/REW NV400-CW/SW/SEW/HEW/REW NF630-CW/SW/SEW/HEW/REW NV630-CW/SW/SEW/HEW	2P, 3P	TCL-4SW3 (*3) (171×99.5×110)	TTC-4SW3 (171×104.5×110)	BTC-4SW3 (140×99.5×42)	PTC-4SW3 (140×99.5×42)
NF400-UEW	3P	TCL-4SW3 (*1) (171×132.5/196.5×110)	—	BTC-4SW3 (*1) (140×132.5/196.5×42)	—
NF400-SW/SEW/HEW, NV400-SEW/HEW NF630-SW/SEW/HEW, NV630-SEW	4P	TCL-4SW4 (240×104.5×110)	TTC-4SW4 (240×104.5×110)	BTC-4SW4 (*2) (185×97.5×39)	—
NF800-CEW/SDW/SEW/HEW/REW, NV800-SEW/HEW	2P, 3P	TCL-8SW3 (224×103.5×155)	TTC-8SW3 (224×103.5×155)	BTC-8SW3 (*2) (210×97.5×32)	—
NF800-UEW	3P	TCL-8UW3 (*1) (220×146/194.5×155)	—	BTC-8SW3 (*1) (210×146/194.5×32) (*2)	—
NF800-SEW/HEW	4P	TCL-8SW4 (294×103.5×155)	TTC-8SW4 (294×103.5×155)	BTC-8SW4 (*2) (280×97.5×32)	—
NF400-UEW, NF800-UEW	4P	TCL-8UW4 (*1) (290×146/194.5×155)	—	BTC-8SW4 (*1) (280×146/194.5×32) (*2)	—
NF1000-SEW NF1250-SEW/SDW	2P, 3P	TCL-10SW3 (220×139×150)	—	—	—
NF1000-SEW NF1250-SEW/SDW	4P	TCL-10SW4 (290×139×150)	—	—	—

Remark: 1. () Shows external dimensions in mm. (A×B×C)

Note (*1) Line side/Load side

(*2) These covers can be mounted on plug-in type.

(*3) Except for NF400/630-HEW/REW and NV400/630-HEW/REW.

5. Accessories

External Accessories

5. Electrical Operation Device

● 250A Frame and less

Table 5-28: Summary of Model Designations

Applicable models		(*)1	NF125-CW(3P) NF125-SW(3P, 4P) NF125-HW	NF160-SW/HW NF250-CW/SW/HW MB225-SW	NF125-SGW/HGW NF160-SGW/HGW NF250-SGW/HGW	NV125-CW/SW/HW	NV250-CW/SW/HW	NV250-SEW/HEW
Rated operating voltage	24V DC		MDS024-NF1SWE	MDS024-NF2SWE	MDS024-NF2GSWE	MDS024-NV1SWE	MDS024-NV2SWE	MDS024-NVE2SWE
	48-60V DC		MDS060-NF1SWE	MDS060-NF2SWE	MDS060-NF2GSWE	MDS060-NV1SWE	MDS060-NV2SWE	MDS060-NVE2SWE
	Compatible to 100-240V AC/100-250V DC		MDSAD240-NF1SWE	MDSAD240-NF2SWE	MDSAD240-NF2GSWE	MDSAD240-NV1SWE	MDSAD240-NV2SWE	MDSAD240-NVE2SWE

Note (*1) Place an order of other models in conjunction with the circuit breaker.

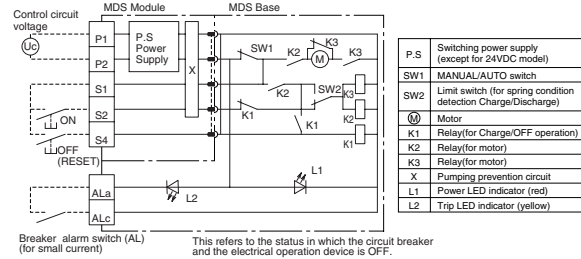

Table 5-29: Specifications

Rated operating voltage (Allowable voltage range 85~110%)	24V DC	48-60VDC	Compatible to 100-240V AC/100-250V DC
Operating time (s)	ON action	0.05~0.1	
	OFF action	0.6 or less	
	Charging action	1.2 or less	
Power requirement (VA)	150		

Remark: 1. The standard terminal cover can be used.
2. Please contact us for details of the outside dimensions.

MDS024 -NF2SWE MDS024 -NV2SWE/NVE2SWE
MDS060 -NF2SWE MDS060 -NV2SWE/NVE2SWE
MDSAD240-NF2SWE MDSAD240-NV2SWE/NVE2SWE



Breaker alarm switch (AL) (for small current) This refers to the status in which the circuit breaker and the electrical operation device is OFF.

others

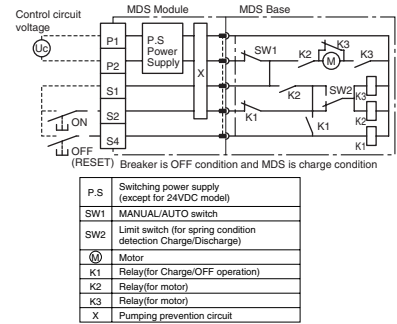

● 400A Frame and more

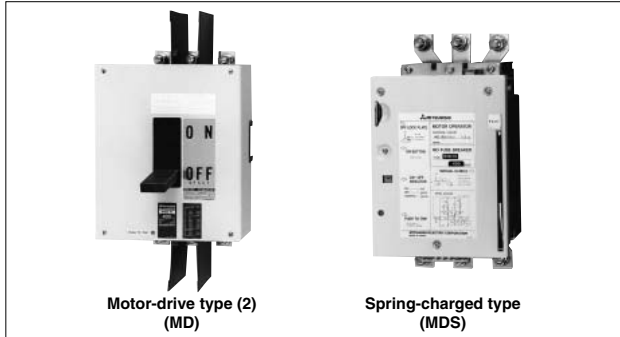

Table 5-30

MCCB type	NF-C series	NF400-CW NF630-CW NF800-CEW	—	NF400-CW NF630-CW NF800-CEW	—			
		NF-S-H series	NF400-SW NF400-SEW/HEW/REW NF630-SW NF630-SEW/HEW/REW NF800-SEW/HEW/REW	NF1000-SEW NF1250-SEW NF1250-SDW NF1600-SEW NF1600-SDW	NF400-SW NF400-SEW/HEW/REW NF630-SW NF630-SEW/HEW/REW NF800-SEW/HEW/REW	NF1000-SEW NF1250-SEW NF1250-SDW NF1600-SEW NF1600-SDW		
	NF-U, MB series	NF400-UW NF800-UW	—	NF400-UW NF800-UW	—			
ELCB type	NV-C series	NV400-CW NV630-CW	—	NV400-CW NV630-CW	—			
	NV-S-H series	NV400-SW NV400-SEW/HEW/REW NV630-SEW/HEW NV800-SEW/HEW	—	NV400-SW NV400-SEW/HEW/REW NV630-SEW/HEW NV800-SEW/HEW	—			
	MN series	—	—	—	—			
Electrical operation system		Motor-drive type (2)	Motor-drive type (2)	Spring-charged type	Spring-charged type			
Rated operating voltage (V) (Allowable voltage range 85~110%) (*1)		100/110VDC, 100/110VAC, 200/220VAC (125VDC, 240VAC)						
Operating current (A, rms) (*1)	DC	100/110V	3.0 (8.0)	4.0 (8.0)	1.0 (3.0)	8	1.0 (3.0)	9
		200/220V	2.0 (4.5)	3.5 (7.0)	0.5 (1.5)	8	0.5 (1.5)	8
	AC	100/110V	4.0 (8.0)	5.0 (10.0)	1.0 (3.0)	10	1.0 (3.0)	10
Operating time (s)	On	Less than 0.3 (self-holding)		0.05		0.07		
	Off	Less than 0.3 (self-holding)		Less than 3 (self-holding)		Less than 3 (self-holding)		
Required transformer capacity (VA)		400	700	700	700	700		
Endurance voltage (V)		1500						

Note (*1) () voltages are special options and might require an external resistor. For details, consult your dealer.
(*2) () shows starting currents.

General precautions for motor-operated electrical MCCBs

- Motor-operated types have intermittent ratings, and therefore they should not be operated more than 10 times consecutively (one on/off counts as an operation).
- The operating voltage should be between 85~110% of the rated control voltage.
- When the breaker is tripped by trip button or breakdown (i.e., overload or short circuit), the breaker will not show that it has been tripped (except for motor-operated type 1 breakers).
- The dielectric strength of the electrical operating circuits is 1500V. When performing a dielectric strength test simultaneously with another device at a voltage over 1500V, the operating circuit terminal should be disconnected.
- Please insulate each electric operation device by the relay when two or more electric operation devices are limped together and operated.

The circumference circuit might be formed when each control terminal is connected parallel directly, and it not operate normally.

Electrically Operated MCCBs and ELCBs

Motor-operated type (2)

- Electrical operation
Forward and reverse motor rotation is changed by ball screw to switch the breaker ON and OFF (reset).
- Manual operation
The manual operation handle can be used to switch the breaker ON and OFF directly.
- Cautions during electrical operation
 1. In case the UVT operates and a circuit breaker trips if the breaker has a UVT, the re-closing procedure may differ according to the state of the breaker before tripping.
When the circuit breaker trips while turned ON..... Reset (OFF) -> Turn ON
When the circuit breaker trips while turned OFF..... Turn ON (idle tripping) -> Reset (OFF) -> Turn ON
(If it fails to turn ON (idle tripping), please operate Reset (OFF) and turn ON.)
 2. Do not send ON and OFF signals consecutively. An interval of at least 0.5s is required between each ON and OFF.
 3. For models with auto reset capability, resetting after an NFB trip should be performed after an interval of 0.5s.

Automatic Reset

- If the breaker is an auto reset type, it contains a built-in alarm switch and the off-control circuit closes when the breaker is tripped. Since the breaker automatically resets itself after tripping, the power is easily restored by switching on the breaker again. With a UVT mounted, however, auto reset may not be possible. In this case, please consult your dealer.

4. The electrical operating device is equipped with a pumping prevention circuit. Although it is possible to set the device to OFF while it is set to ON, it is impossible to return it to ON immediately. To return to ON, first shut off the ON switch, then set it back to ON.
5. Special care is required during electrical operation because the manual operation handle moves at high speed. Also be sure to turn off the circuit power supply when using manual operation.
6. With manual operation, ensure that the handle is fully extended.



Manual operation

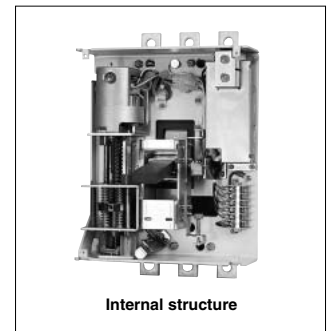

Internal structure

Control circuit

The dotted line shows an additional connection for the automatic-reset type.

(1) Control circuit 1.
(400,630 and 800AF)

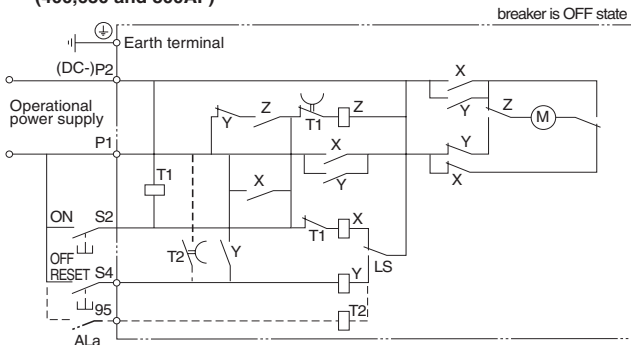

(2) Control circuit 2.
(NF1000-SEW to NF 1600-SEW)

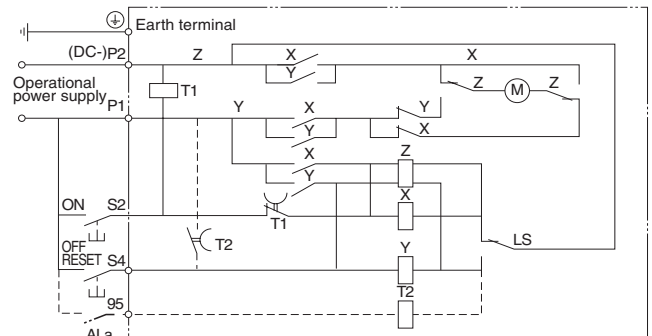

- M :Motor
- X :Relay for ON operation
- Y :Relay for OFF operation
- Z :Relay for changing Motor polarity
- T1 :Timer for antipumping
- T2 :Timer for automatic reset
- LS :Limit Switch
- ALa :Alarm switch for automatic reset (a contact)

5. Accessories

External Accessories

Spring-charged type

- Electrical operation

When the ON switch is closed, the coil is excited to release the latch mechanism and the force of the closing spring turns the breaker ON instantly.

When the OFF switch is closed, a relay starts the motor which turns the breaker OFF and charges the spring simultaneously.

- Manual operation

Pressing the ON button will release the latch mechanism and the force of the closing spring turns the breaker ON instantly.

Pressing the leaf spring, pulling out the manual handle and pumping it back and forth over 10 times will turn the breaker OFF and charge the spring at the same time.

- Cautions during electrical operation

Whenever an electrical operation device is to be installed in or removed from the breaker, the breaker must be tripped and the device discharged.

Pushing the TRIP button on an MCCB with an electrical-operation device installed will not trip the breaker in the OFF state. This does not mean the breaker is faulty.

Switching OFF a breaker with an electrical-operation device installed will take 3s. If instant opening is required, install an SHT or UVT to the breaker.

- The breaker contains a built-in pumping-prevention relay.

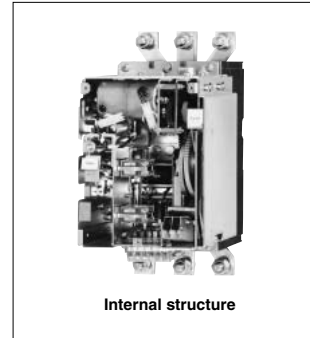

Control circuit

The dotted line shows an additional connection for the automatic-reset type.

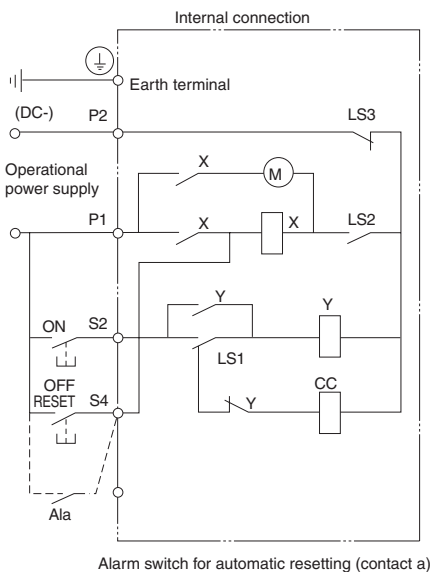

CC.....Coil for making
 Y.....Relay for pumping prevention
 X.....Relay for self-sustaining on OFF side
 LS1...Limit switch interlocking with cam
 LS2...Limit switch interlocking with cam
 LS3...Limit switch interlocking with OFF lock plate
 M.....Motor

Dimensions

Front connection

● NF125-CW, NF125-SW, NF125-HW

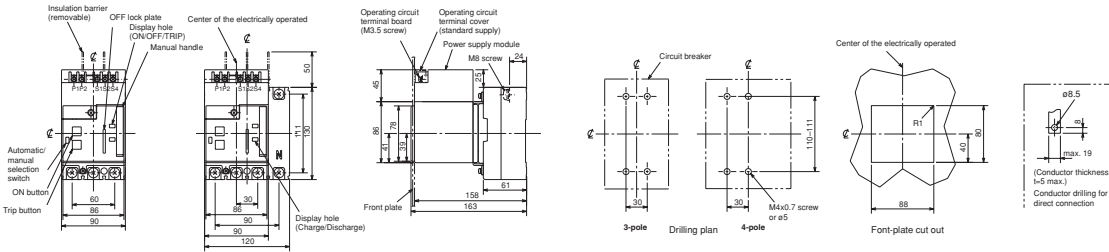

Remarks:
 The 2-pole models are 3-pole models with the central pole removed.
 The three-pole type only is available for the model NF125-CW, and the 3-pole and 4-pole types only are available for the model NF125-SW.

● NF160-SW, NF160-HW, NF250-CW, NF250-SW, NF250-HW, MB225-SW

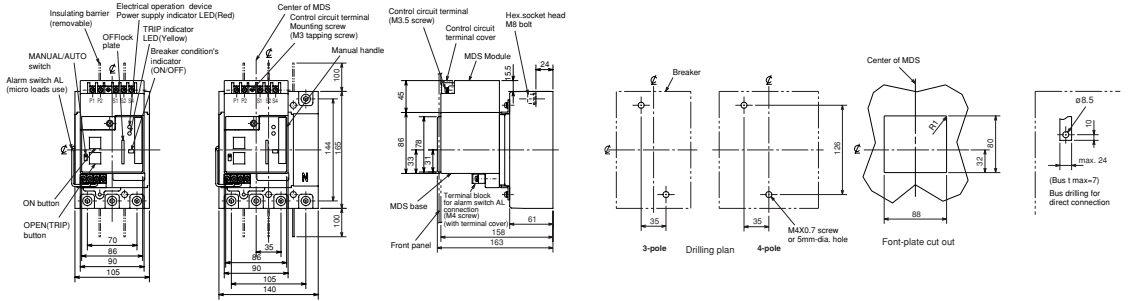

Note. 1. One AL (micro loads use) is used for the LED display for a trip indicator check.
 2. 2-pole breakers are 3-pole breakers with the central pole removed.
 3. NF250-CW is available in 2- and 3-pole only.
 MB225-SW is available in 3-pole only.

● NF125-SGW, NF125-HGW, NF160-SGW, NF160-HGW, NF250-SGW, NF250-HGW

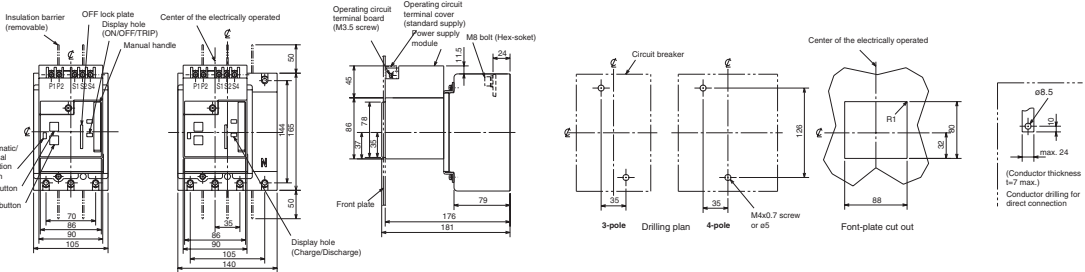

● NV125-CW, NV125-SW, NV125-HW

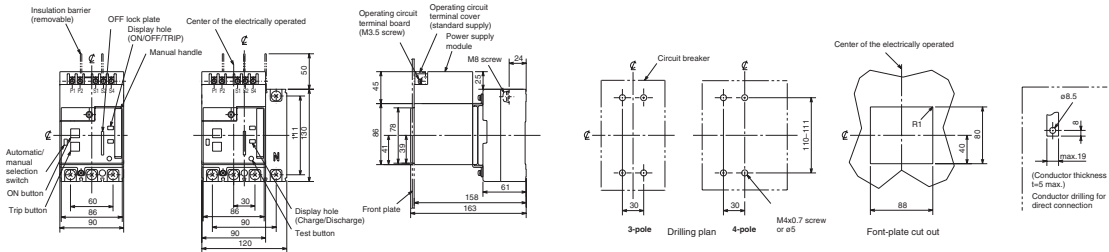

● NV250-SEW, NV250-HEW

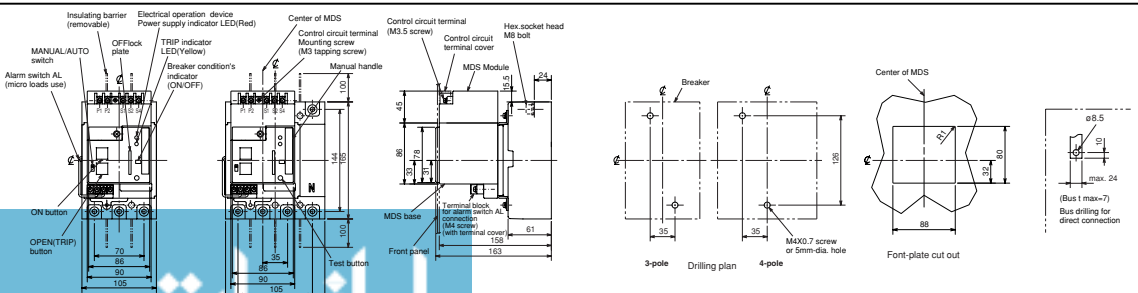

Note. 1. One AL (micro loads use) is used for the LED display for a trip indicator check.
 2. 4-pole breakers are only NV250-SEW.

5

5. Accessories

External Accessories

Front connection

● NF400-CW, NF400-SW, NF400-SEW, NF400-HEW, NF400-REW Motor drive type (2)

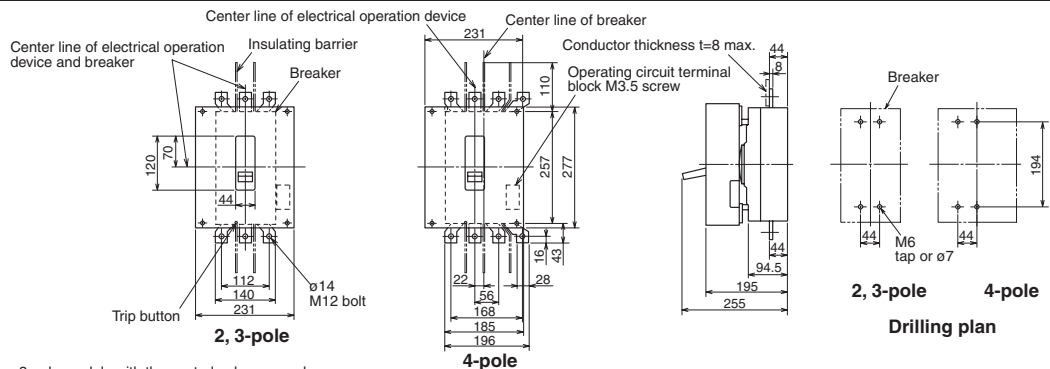

● NF400-UW (3-pole) Motor drive type (2)

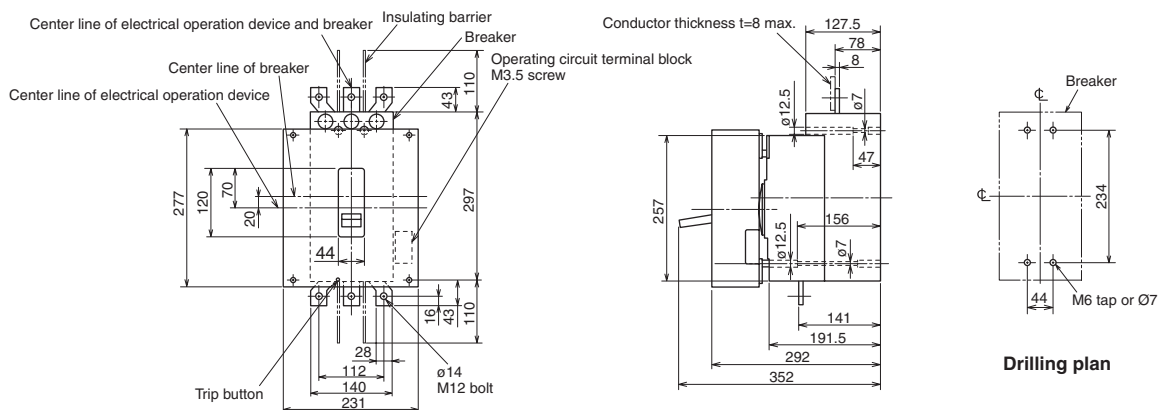

● NV400-CW, NV400-SW, NV400-SEW, NV400-HEW, NV400-REW Motor drive type (2)

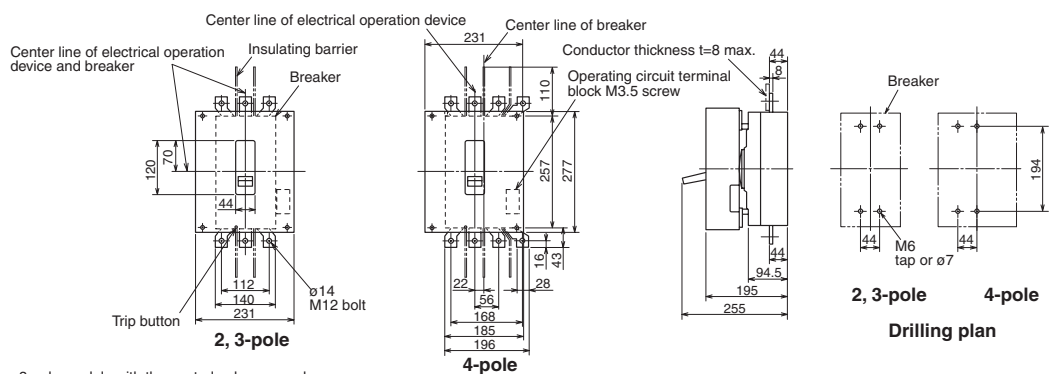

● NF630-CW, NF630-SW, NF630-SEW, NF630-HEW, NF630-REW Motor drive type (2)

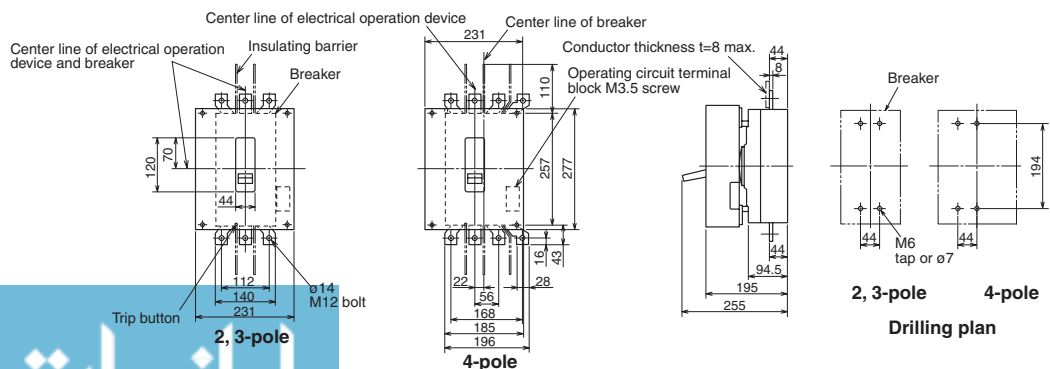

Front connection

● NF400-UEW 4-pole Motor drive type (2)

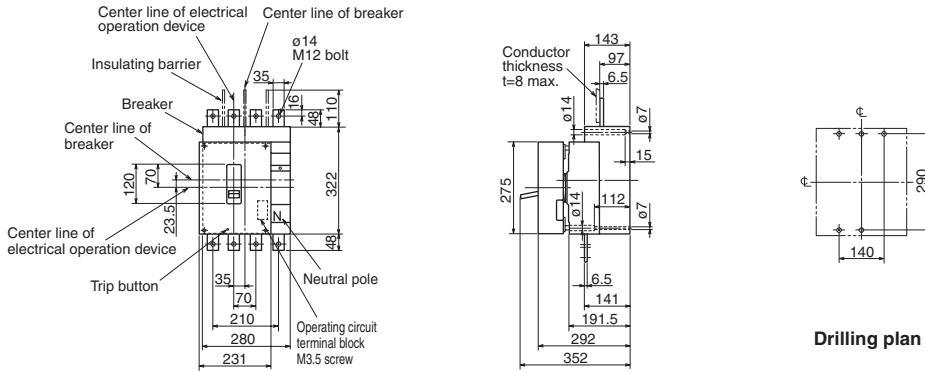

● NV630-CW, NV630-SW, NV630-SEW, NV630-HEW Motor drive type (2)

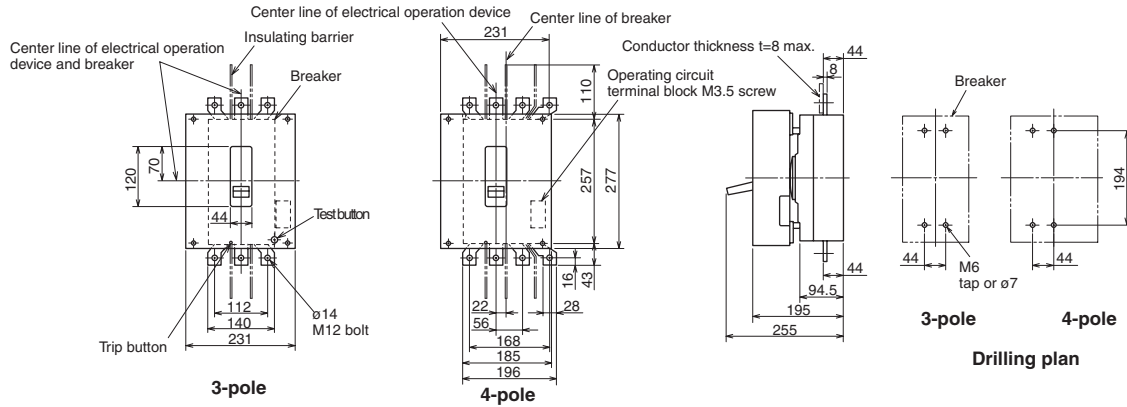

● NF800-CEW, NF800-SDW, NF800-SEW, NF800-HEW, NF800-REW Motor drive type (2)

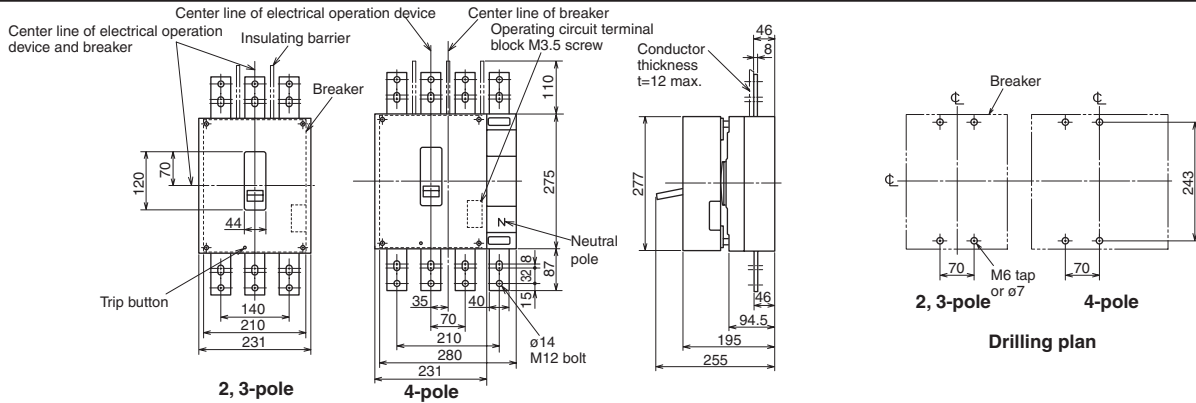

Remark: 2 pole models are 3-pole models with the central pole removed.

● NF800-UEW Motor drive type (2)

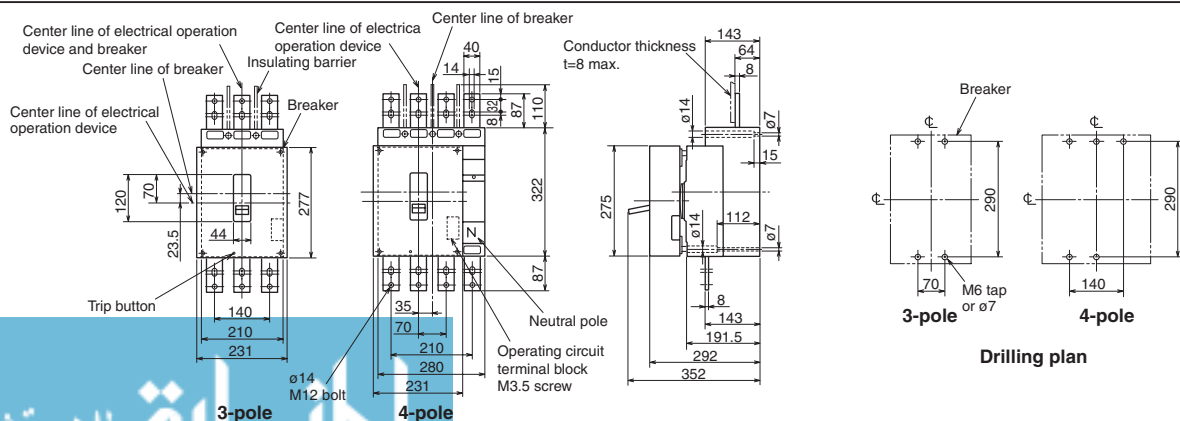

5. Accessories

External Accessories

Front connection

● NV800-SEW, NV800-HEW Motor drive type (2)

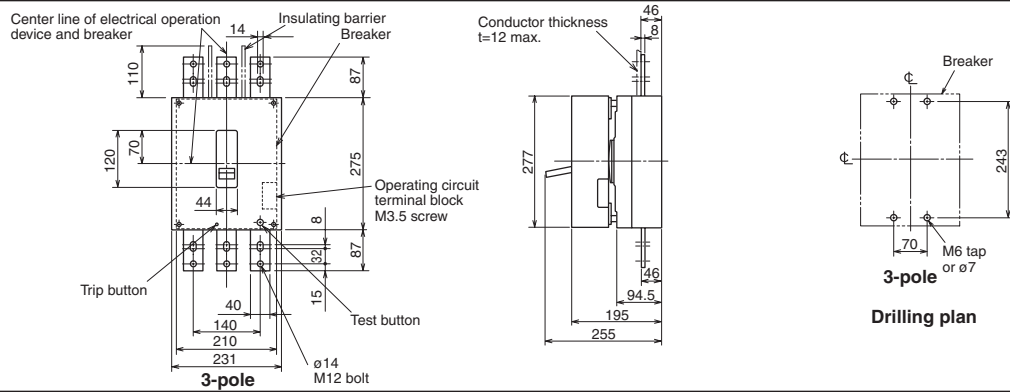

● NF1000-SEW, NF1250-SEW, NF1250-SDW Motor drive type (2)

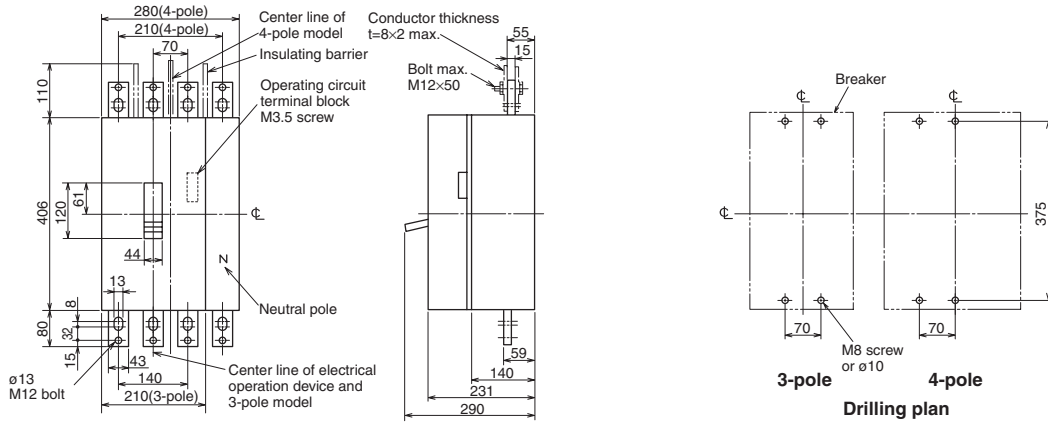

● NF1600-SEW, NF1600-SDW Motor drive type (2)

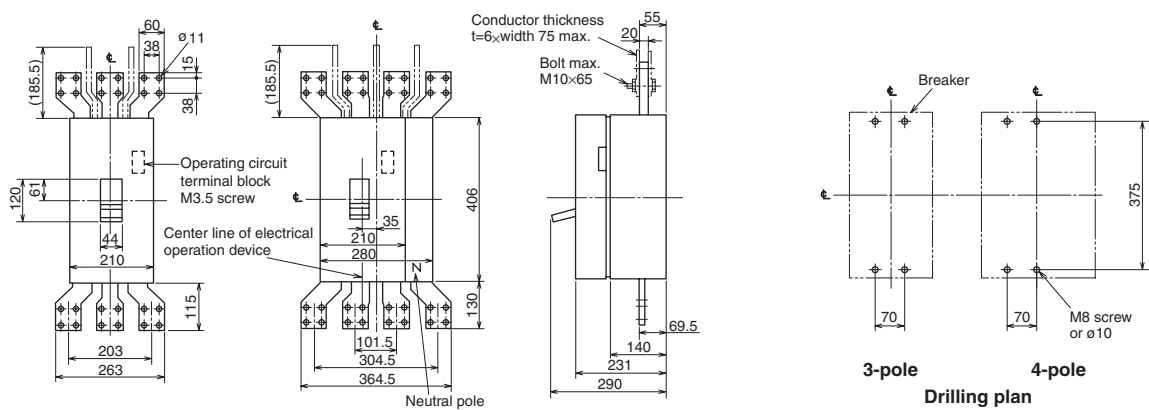

Rear connection

● NF1600-SEW (3-pole) Motor drive type (2)

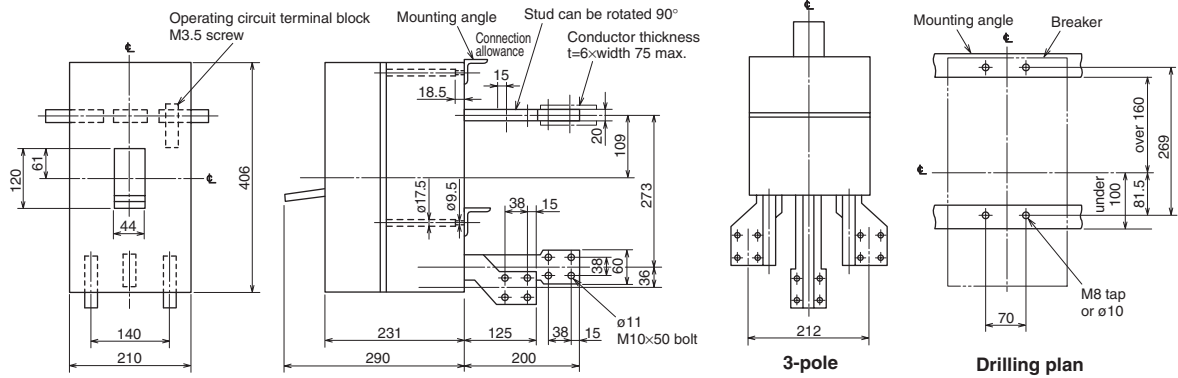

● NF1600-SEW (4-pole) Motor drive type (2)

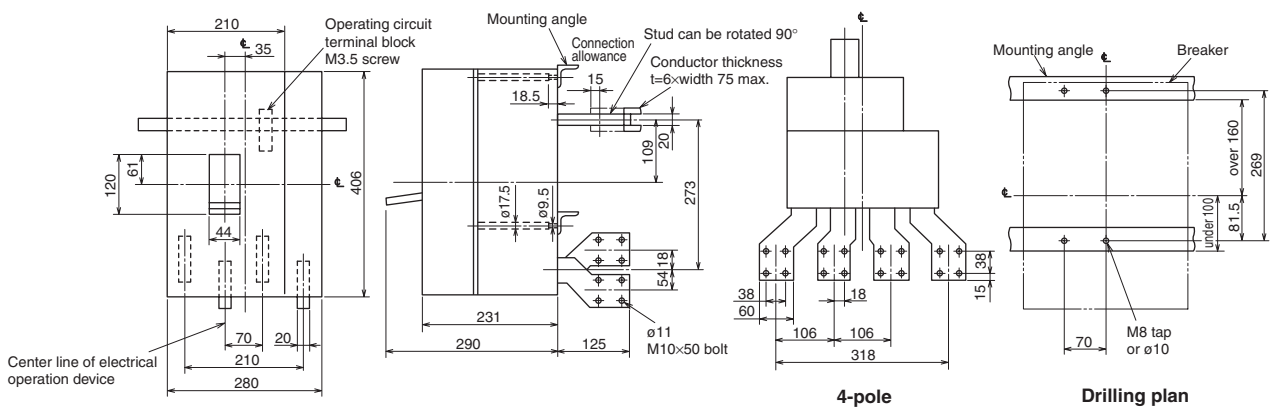

● NF1600-SDW Motor drive type (2)

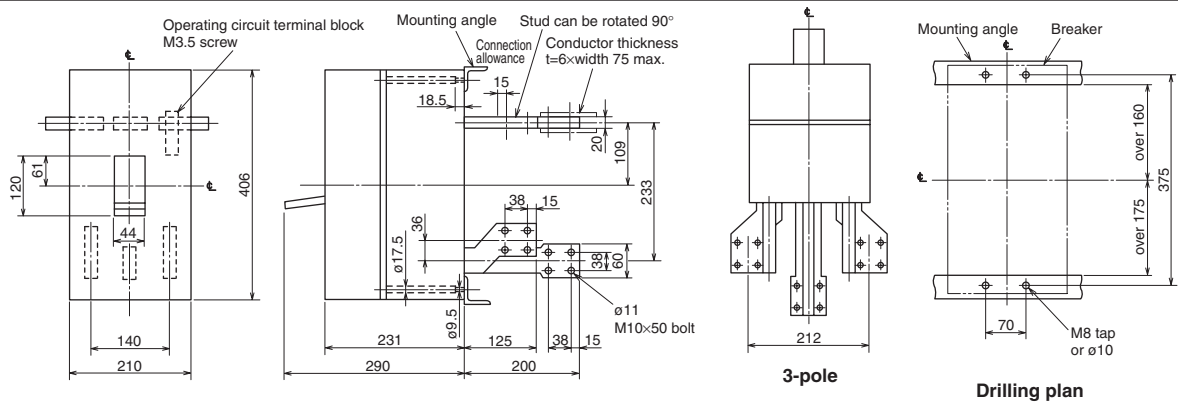

● NF1600-SDW (4-pole) Motor drive type (2)

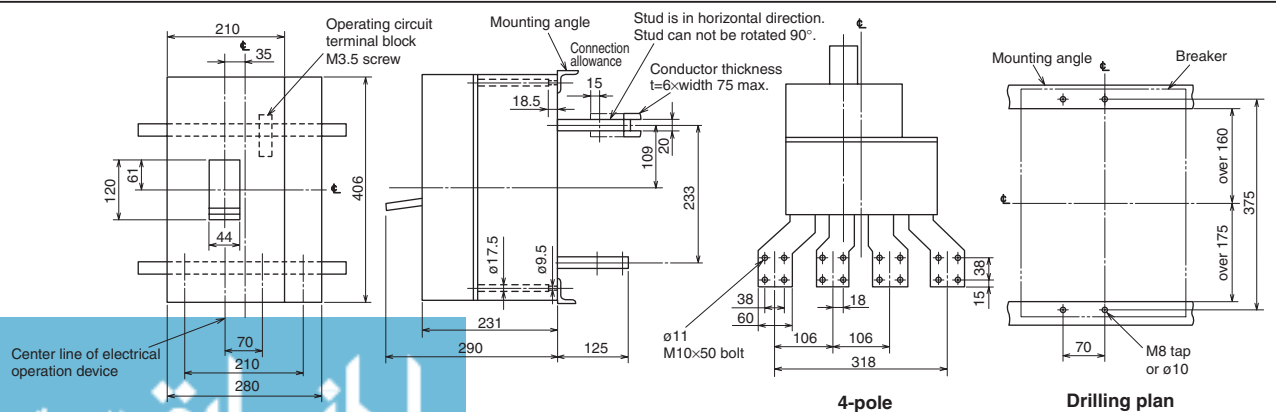

5

5. Accessories

External Accessories

6. Mechanical Interlocks (MI)

Table 5-33

Applicable models	Number of poles	Panel mounting		Direct mount on circuit breaker
		Front connection, Rear connection, Plug-in	Dimension A mm	
NF32-SW, NF63-CW/SW/HW	2P	MI-05SW3	47.5	-
NF32-SW, NF63-CW/SW/HW, NV32-SW, NV63-CW/SW/HW, MB30-SW, MB50-CW/SW	3P		-	MI-05SWFB3
NF63-SW/HW	4P	MI-05SW4	-	-
NF125-CW/SW/HW	2P	MI-05SW3	45	-
NF125-CW/SW/HW, NV125-CW/SW/HW, MB100-SW, NV125-RW	3P			MI-1SWFB3
	4P	MI-1SW4	-	-
NF160-SW/HW, NF250-CW/SW/HW, NV250-CW/SW/HW, NV250-SEW/HEW, MB225-SW, NV250-RW	2P	MI-05SW3	-	MI-2SWFB3
	3P			-
NF160-SW/HW, NF250-SW/HW, NV250-SW/HW/SEW/HEW	4P	MI-2SW4	-	-
NF125-SGW/HGW/RGW/UGW, NF160-SGW/HGW, NF250-SGW/HGW/RGW/UGW	3P	MI-05SW3	-	MI-2GSWFB3
NF125-SGW/HGW/UGW, NF160-SGW/HGW, NF250-SGW/HGW/UGW	4P	MI-2SW4	-	-

● Outside Dimension Diagram

(Front connection, Rear connection, and Plug-in)

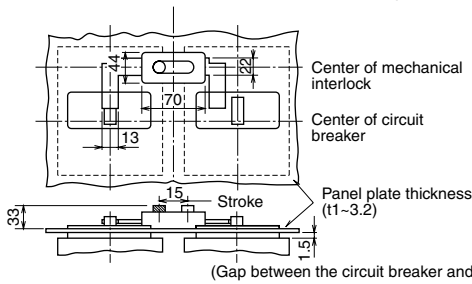

● Drilling Dimension Diagram

(Front connection, Rear connection, and Plug-in)

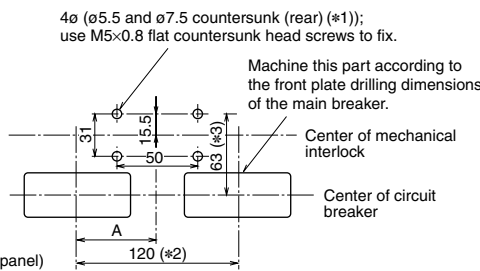

Note (*1) When the panel plate thickness is 2.3 or more, prepare four holes (ø5.5 and ø9.5 countersunk (rear)).

(*2) These are standard dimensions for 2- and 3-pole models, but can be altered upon request.

(*3) The U series have different dimensions. Please contact us for details.

Remark: 1. Please contact us for outside dimensions of other models of different specifications.

2. These are not isolation-compatible.

● Front, Rear, Plug-in

With two breakers, use a panel-mounted mechanical interlock for one-way only input. A breaker-mounting mechanical to mount on the breaker main unit can be made to order. Consult your dealer for more details.

Front, Rear, Plug-in (panel mounting)

Breaker mounting (front)

Type	F	G	P
MI-4SWFB3	44	194	190
MI-8SWFB3	70	243	260

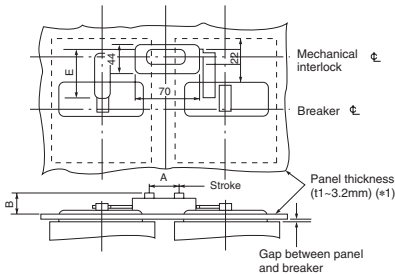

External dimensions

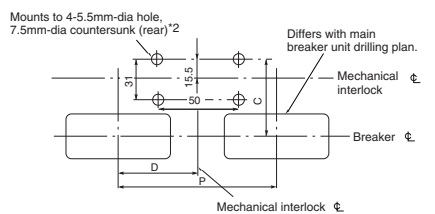

Drilling plan Fig.1

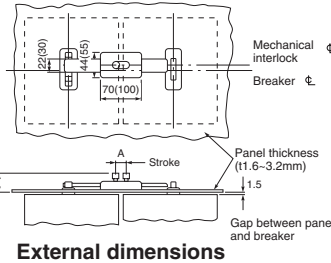

External dimensions

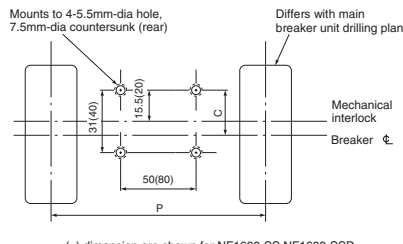

Drilling plan Fig.2

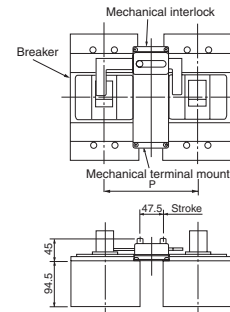

External dimensions

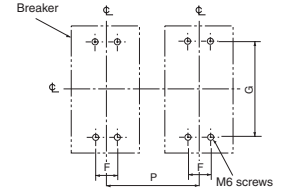

Drilling plan(breaker mount) Fig.3

Note (*1) Above 400AF, use panel thickness t=1.6-3.2mm.

(*2) When the panel thickness is greater than t=2.3mm, use 4-5.5mm-dia 9.5mm dia countersunk (rear).

● Table of Altered Dimensions

Table 5-34

Breaker type		Pitch (P) (*1)			Dimensions (mm)							Breaker mount (*4)		
MCCB	ELCB	Standard		Special Standard	Standard	t	A	B	C (*3)	D	E	Fig.	Type	Fig.
		Type	2P	3P										
NF400-CW/SW/SEW/HEW/REW	NV400-CW/SW/SEW/HEW/REW	MI-4SW3	190		210	-	47.5	33	83.5	-	74	Fig.1	MI-4SWFB3	Fig.3
NF630-CW/SW/SEW/HEW/REW	NV630-CW/SW/SEW/HEW		-										220	
NF400-UEW(3P)	-	MI-8SW3	190		240	-	47.5	33	83.5	-	74	Fig.1	MI-8SWFB3	-
NF800-CEW/SDW/SEW/HEW/REW	NV800-SEW/HEW		-										220	
NF400-UEW(4P), NF800-UEW	-	M-10SW3	220		-	-	47.5	47	37.5	-	-	Fig.2	-	-
NF1000-SEW, NF1250-SEW/SDW	-		-										220	
NF1600-SEW/SDW	-	M-16SW3	315		-	-	65	54.5	39	-	-	-	-	-

Note (*1) Specify the breaker mounting pitch (P)

(*2) No need to specify the panel thickness (t). (Usable panel thickness range: t=1-3.2mm. Above 400AF, use panel thickness t=1.6-3.2mm.)

(*3) For isolation purposes with 400/630/800AF models, keep the C dimension deviation within ±1mm.

(*4) Enquire for more details.

7. Handle Lock Devices and Card Holder

Table 5-35

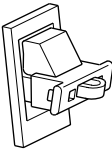
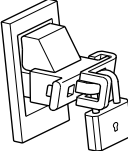
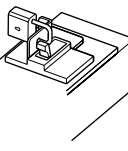
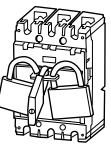
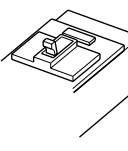

Description		Lock cover (LC)	Handle lock (HL)	Handle lock (HL-S) (*2)	OFF Lock with 3 Padlock	Card holder
Appearance						
NF30-CS, MB30-CS	2P	LC-03CS	HL-05FH	—	—	CH-P No.5
NF30-CS, NV30-CS, MB30-CS	3P					
NF32-SW, NF63-CW/SW/HW	2P	LC-05SW	HLF-05SW HLN-05SW	HLS-05SW2P HLS-05SW	—	
NF32-SW, NF63-CW/SW/HW, NV32-SW, NV63-CW/SW/HW MB30-SW, MB50-CW/SW	3P					
NF63-SW/HW	4P					
NF125-CW/SW	2P					
NF125-HW	2P	LC-1SW	HLF-1SW HLN-1SW	HLS-1SW2P HLS-1SW	—	
NF125-CW/SW/HW, NV125-CW/SW/HW MB100-SW, NV125-RW	3P					
NF125-SW/HW, NV125-SW/HW	4P					
NF160-SW/HW, NF250-CW/SW/HW, NV250-CW/SW/HW NV250-SEW/HEW, MB225-SW NV250-RW	2P 3P 4P	LC-2SW	HLF-2SW HLN-2SW	HLS-2SW	—	
NF125-SGW/HGW, NF160-SGW/HGW, NF250-SGW/HGW NF125-RGW/UGW, NF250-RGW/UGW	3P, 4P	LC-2GSW	HLF-2GSW HLN-2GSW	HLS-2GSW	HLF3-2GSW	

Note (*1) HLF types are used for OFF-lock, and HLN types for ON-lock.

(*2) HL-S types are used for OFF-lock.

Remark: 1. Users are requested to prepare padlocks for HL and HL-S types. (25mm padlock for HL, and 35mm padlock for HL-S.)

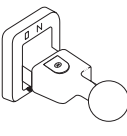
Table 5-36

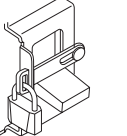
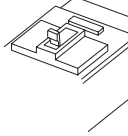
Product	Handle (HT)	Handle lock (HL)	Handle lock (HL-S)	Card holder
Breaker type				
NF400-CW, NV400-CW	HT-4CW	HL-4CW (*1)	HLS-4SW (*2)	CH-P No.3
NF400-SW/SEW/HEW/REW/UEW NV400-SW/SEW/HEW/REW NF630-CW/SW/SEW/HEW/REW NV630-CW/SW/SEW/HEW	HT-4SW	HL-4SW (*1)		
NF400-UEW (3P)			HLS-4UW (*2)	
NF400-UEW (4P) NF800-CEW/SDW/SEW/HEW/REW/UEW NV800-SEW/HEW	HLS-8SW (*2) HLS-8UW (*3)			
NF1000-SEW NF1250-SEW/SDW NF1600-SEW/SDW		HT-10SW		

Note (*1) The HL without padlock can be used as a lock cover (LC).

(*2) Must be ordered with breaker.

(*3) Applicable types are NF400-UEW (4P) and NF800-UEW (3P, 4P).

Remark: 1. Padlocks for HL and HL-S must be provided by the customer.

8. IEC 35mm Rail Mounting Adapters

Table 5-37

Applicable models	Number of poles	Parts number	Outline
NF30-CS, NV30-CS, MB30-CS	2P, 3P	DIN-03CS	Fig.1
NF32-SW, NF63-CW/SW/HW NV32-SW, NV63-CW/SW/HW, MB30-SW MB50-CW/SW	2P 3P	DIN-05SW	Fig.2
NF125-CW/SW	2P	DIN-1SW2	Fig.3
	3P	DIN-1SW3	
NF125-HW, NV125-CW/SW/HW, MB100-SW	2P 3P		

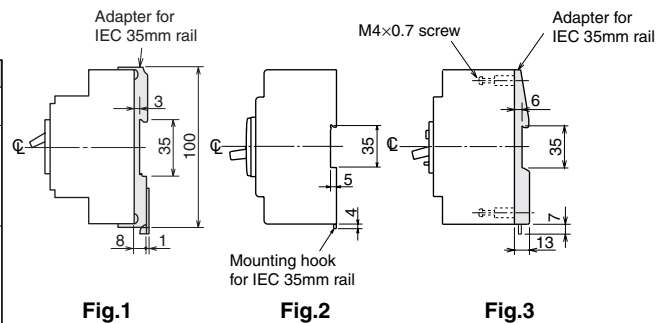

6. Characteristics and Dimensions

Molded-Case Circuit Breakers and Motor Breakers

NF30-CS
MB30-CS



Type NF30-CS

Series		C series		
Frame size		30		
Type name		NF30-CS	MB30-CS	
Rated current In (Amp.)		3, 5, 10, 15, 20, 30	(2), (3.2), 4, (5), 6.3, (8), 10, 16	
Number of poles		2	3	
Rated insulation voltage Ui (V)		500		
Rated short-circuit breaking capacity (kA)	IEC 60947-2 (Icu/Ics)	AC	690V	—
			500V	—
			415V	1.5/1.5
			380V	1.5/1.5
			240V	2.5/2
Standard Attached Parts (Front connection)		Mounting screw: M4×0.7×20 (2pcs) Small terminal cover 2pcs Only MB30-CS		

Operating Characteristics

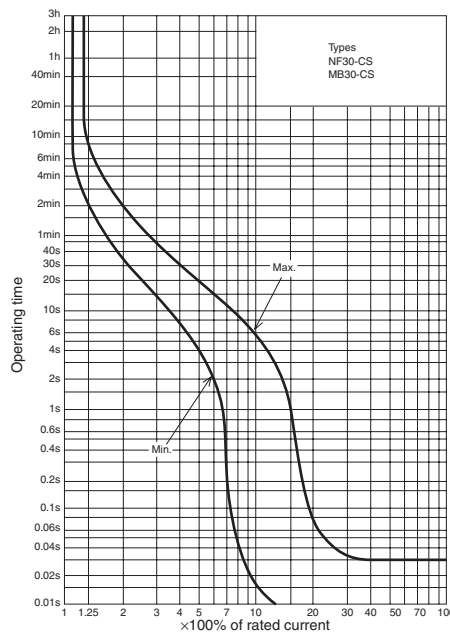

Internal Accessories

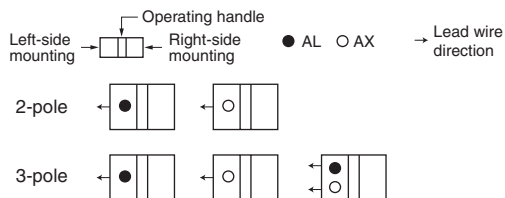

Remark: 1. Standard lead wire is drawn from side. However, lead wire drawn by load can be produced upon request.
2. Refer to page 48.

Temperature Characteristics

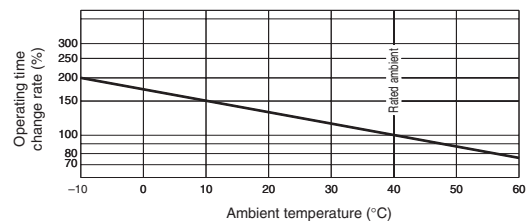

External Accessories

Accessories		Type name	Reference page
Terminal cover	Small	(TC-S) TCS-03CS3W (*1)	70
	Large	(TC-L) TCL-03CS3W (*1)	
	Rear	(BTC) BTC-03CS3W (*1)	
	Skeleton	(TTC) TTC-03CS (*1)	
Handle lock		(HL) HL-05FH	80
Lock cover		(LC) LC03CS	80
Rail mounting adapters		(DIN) DIN-03CS	80

Note (*1) The designation depends on the number of poles. Refer to the reference page.

Front connection

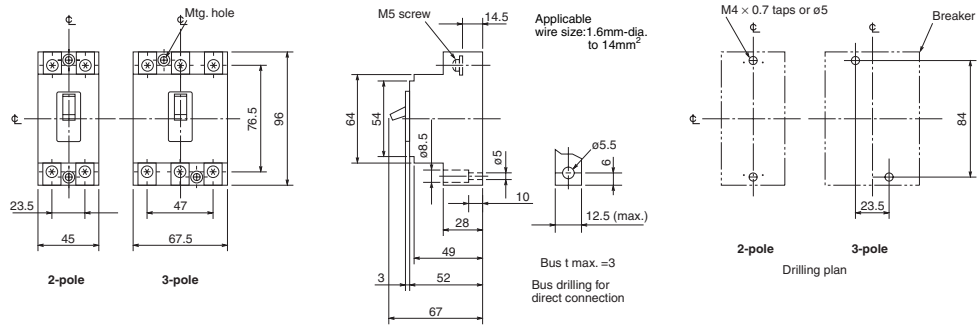

Rear connection

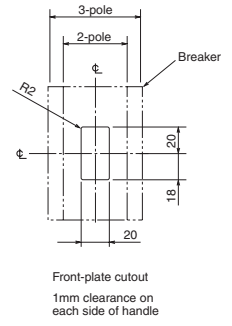
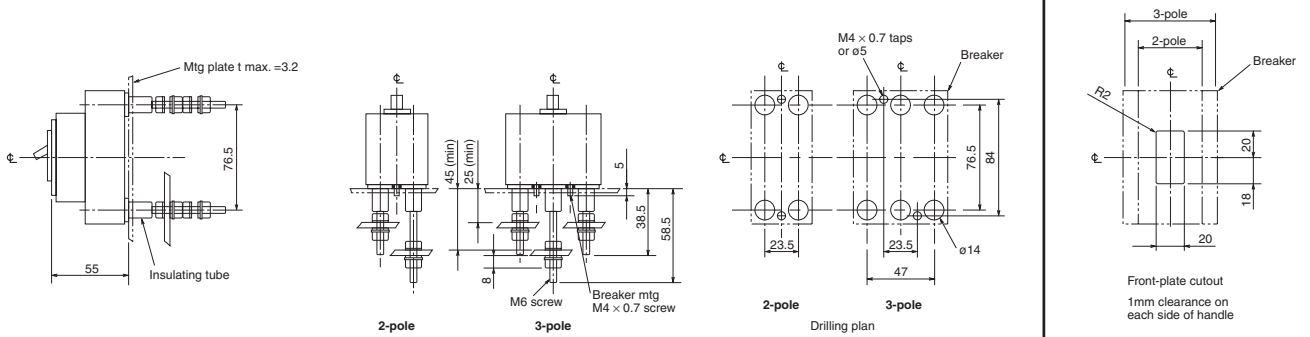

IEC Rail Mounting Adapter

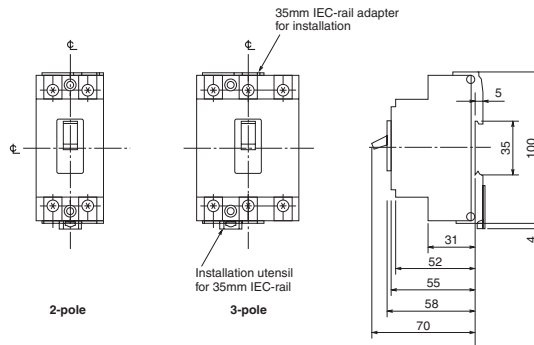

6. Characteristics and Dimensions

Molded-Case Circuit Breakers and Motor Breakers

NF32-SW **NF63-CW**
NF63-SW **NF63-HW**
MB30-SW **MB50-CW**
MB50-SW



Type NF63-SW

Type name	NF32-SW	NF63-CW	NF63-SW	NF63-HW	MB30-SW	MB50-CW	MB50-SW		
Rated current In (Amp.)	3 4 (5) 6 10 (15) 16 20 25 (30) 32	3 4 (5) 6 10 (15) 16 20 25 (30) 32 40 50 (60) 63	3 4 (5) 6 10 (15) 16 20 25 (30) 32 40 50 (60) 63	10 (15) 16 20 25 (30) 32 40 50 (60) 63	0.8 1.2 1.4 2 2.5 4 5 7.1 8 10 12 16 25 32	8 10 12 16 25 32 40 45	0.8 1.2 1.4 2 2.5 4 5 7.1		
Number of poles	2 (*1) 3	2 (*1) 3	2 (*1) 3 4	2 (*1) 3 4	3	3	3		
Rated insulation voltage Ui (V)	600	600	600	690	500	500	500		
Rated short-circuit breaking capacity (kA)	IEC 60947-2 (Icu/Ics)	AC	690V	—	—	—	2.5/1	—	—
			500V	2.5/1	2.5/1	7.5/4	7.5/4	—	—
			440V	2.5/1	2.5/1	7.5/4	10/5	2.5/1	2.5/1
			400V	5/2	5/2	7.5/4	10/5	5/2	5/2
			230V	7.5/4	7.5/4	15/8	25/13	7.5/4	7.5/4
			DC	250V	2.5/1	—	2.5/1	—	7.5/4
Standard Attached Parts (Front connection)	Mounting screw: M4×0.7×55 (2 and 3P: 2pcs, 4P: 4pcs) Insulation barrier: (2P: 1pc, 3P: 2pcs, 4P: 3pcs) (*2)								

Note (*1) Types of DC specifications can be produced upon request.
 (*2) These are supplied with NF63-SW, NF63-HW, and MB50-SW models.

Operating Characteristics

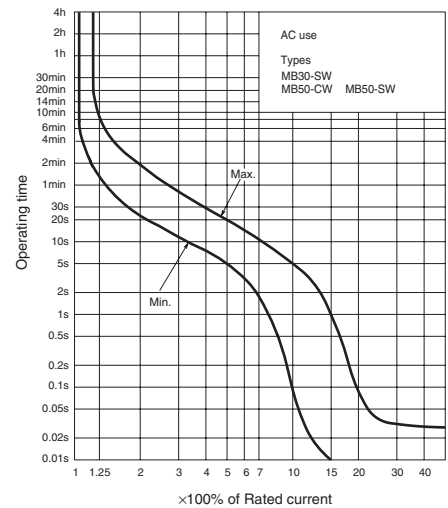
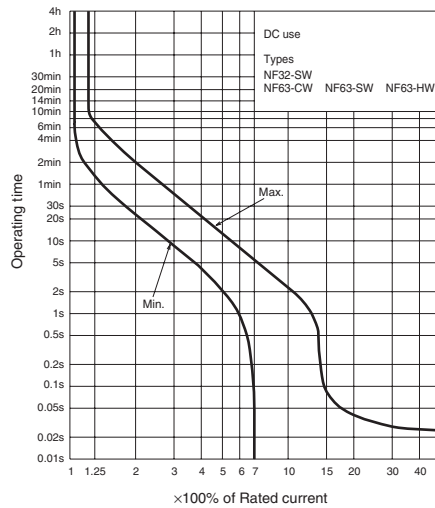
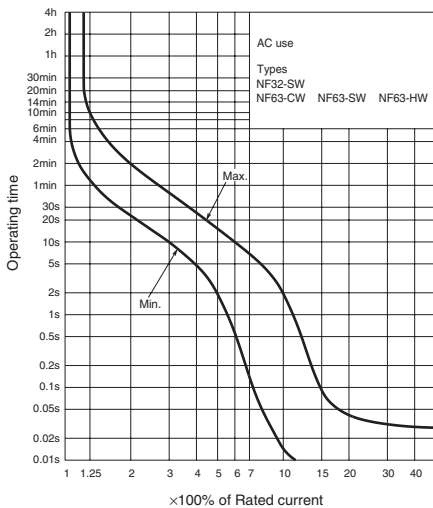

Internal Accessories

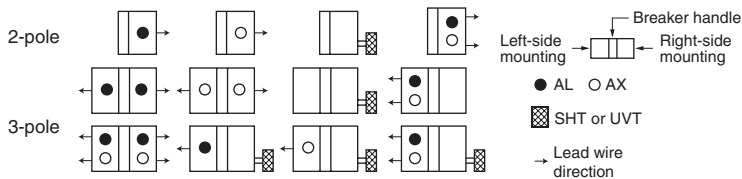

Remark: 1. Refer to page 48.

Temperature Characteristics

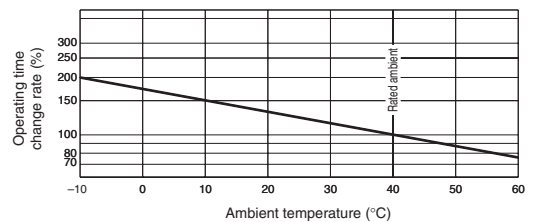

External Accessories

Accessories	Type name	Reference page	Accessories	Type name	Reference page
Operating handle	F F-05S (*1)	61	Mechanical interlock	MI MI-05SW3 (*1)	79
	V V-05S	64		Terminal cover	Small TC-S TCS-05SW3W (*1)
	S S05SW	68	Large TC-L TCL-05SW3W (*1)		
Handle lock device	(*2) HLF-05SW	80	Skeleton TTC TTC-05SW3 (*1)		
	HL HLN-05SW		Rear BTC BTC-05SW3W (*1)		
	HL-S HLS-05SW (*1)		Plug-in PTC PTC-05SW3W (*1)		
IEC 35mm rail mounting adapters (option)			DIN-05SW	80	

Note (*1) The designation depends on the number of poles. Refer to the reference page.
 (*2) HLF types are used for OFF-lock, and HLN types for ON-lock.

Front connection

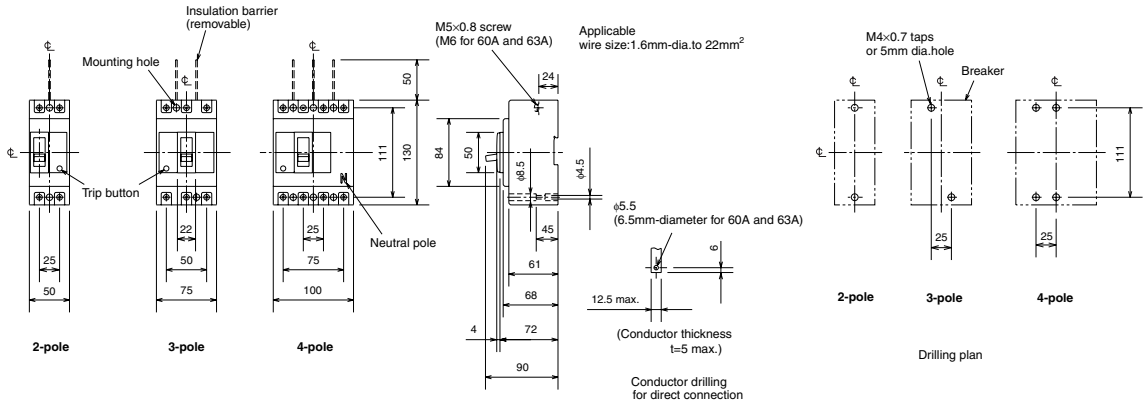

Rear connection

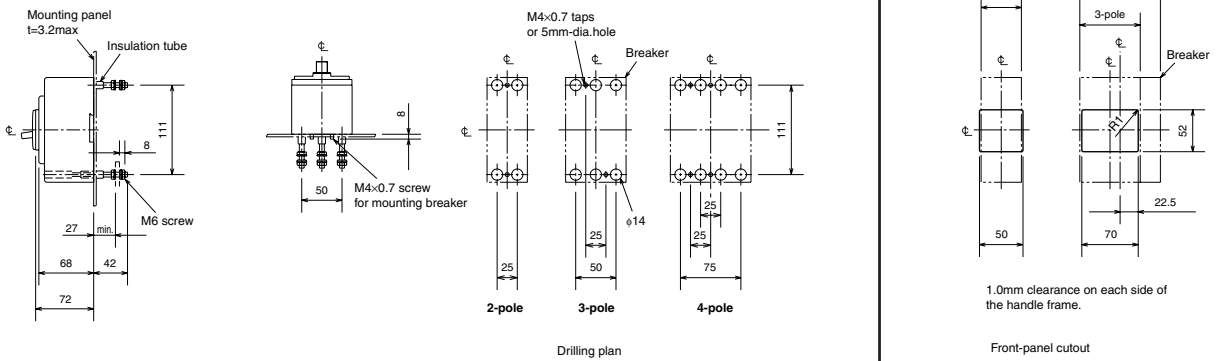

Plug-in

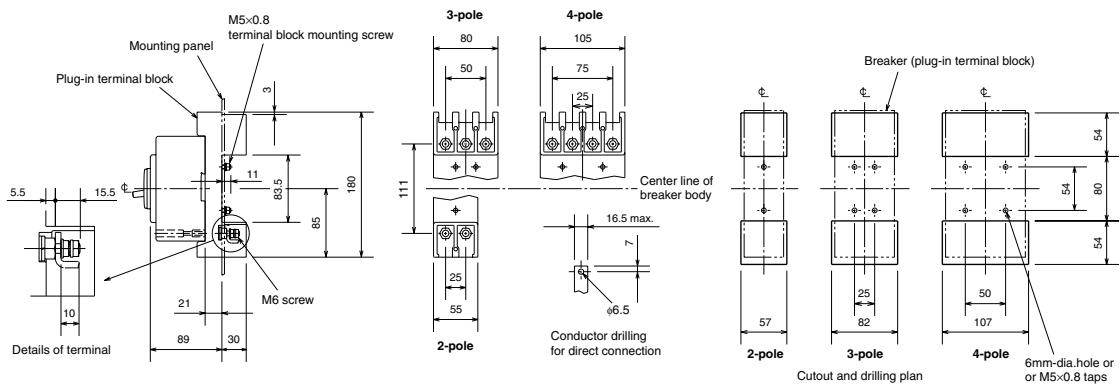

6. Characteristics and Dimensions

Molded-Case Circuit Breakers and Motor Breakers

NF125-CW NF125-SW
NF125-HW MB100-SW



Type NF125-SW

Type name		NF125-CW			NF125-SW			NF125-HW			MB100-SW				
Rated current In (Amp.)		50 (60) 63 (75) 80 100 125			(15) 16 20 (30) 32 40 50 (60) 63 (75) 80 100 125			(15) 16 20 (30) 32 40 50 (60) 63 (75) 80 100			(12.5) (16) (25) 32 (40) 45 63 71 90 100				
Number of poles		2 3			2 3 4			2 3 4			3				
Rated insulation voltage Ui (V)		600			690			690			500				
Rated short-circuit breaking capacity (kA)	IEC 60947-2 (Icu/Ics)	AC	690V	-			8/4			10/5			-		
			500V	7.5/4			18/9			30/15			-		
			440V	10/5			25/13			50/25			25/13		
			400V	10/5			30/15			50/25			30/15		
		DC (*1)	230V	30/15			50/25			100/50			50/25		
			250V	7.5/4	-		15/8	-		40/20	-		-		
			400V	-	7.5/4	-		15/8	-		40/20	-		-	
			500V	-			-			15/8	-		40/20	-	
Standard Attached Parts (Front connection)		Mounting screw: M4×0.7×55 (2 and 3P: 2pcs, 4P: 4pcs) Insulation barrier: (2P: 1pc, 3P: 2pcs, 4P: 3pcs) (*2)													

Note (*1) When wired as shown at the bottom of page 13, 3-pole models can be used for up to 400 V DC, and 4-pole models for up to 500 V DC.

(*2) These are supplied with NF125-SW, NF125-HW, and MB100-SW models.

Operating Characteristics

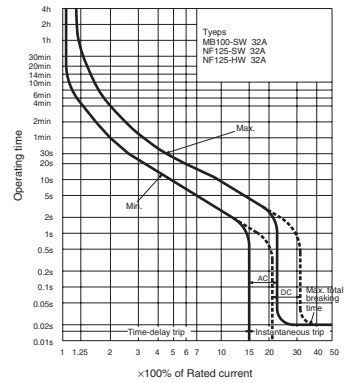
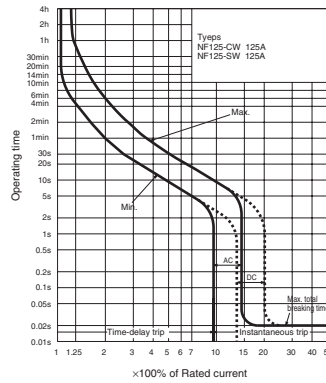
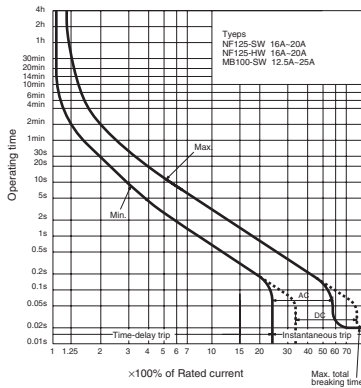
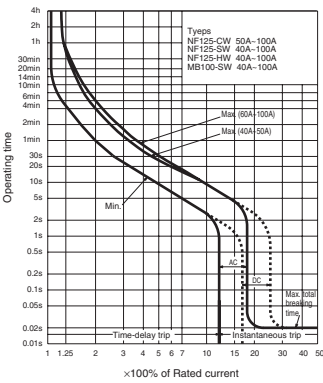

Remark: 1. Only AC characteristics are available for the model MB100-SW.

Internal Accessories

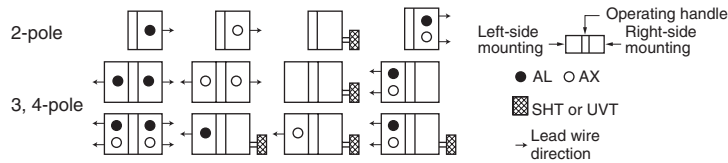

Remark: 1. Refer to page 48.

Ambient Compensating Curve

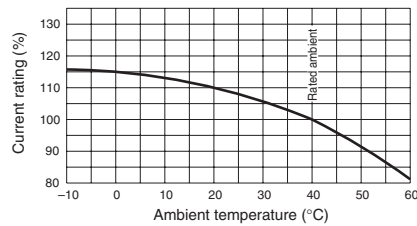

External Accessories

Accessories	Type name	Reference page	Accessories	Type name	Reference page
Operating handle	F F-1S (*1)	61	Mechanical interlock	MI MI-05SW3 (*1)	79
	V V-1S	64		Terminal cover	Small TC-S TCS-1SW3W (*1)
	S S1SW	68	Large TC-L TCL-1SW3W (*1)		
Handle lock device	LC LC-1SW	80	Skeleton TTC TTC-1SW3 (*1)		
	(*2) HLF-1SW		Rear BTC BTC-1SW3W (*1)		
	HL HLN-1SW		Pulg-in PTC PTC-1SW3W (*1)		
	HL-S HLS-1SW (*1)(*2)		IEC 35mm rail mounting adapters	DIN-1SW3 (*1)	80
			Electrical operation device	MDS-NF1SWE (*3)	71

Note (*1) The designation depends on the number of poles. Refer to the reference page.

(*2) Specify the working voltage. An order should be placed at the same time as an order of circuit breaker main body.

(*3) HLF and HLS types are used for OFF-lock, and HLN types for ON-lock.

Front connection

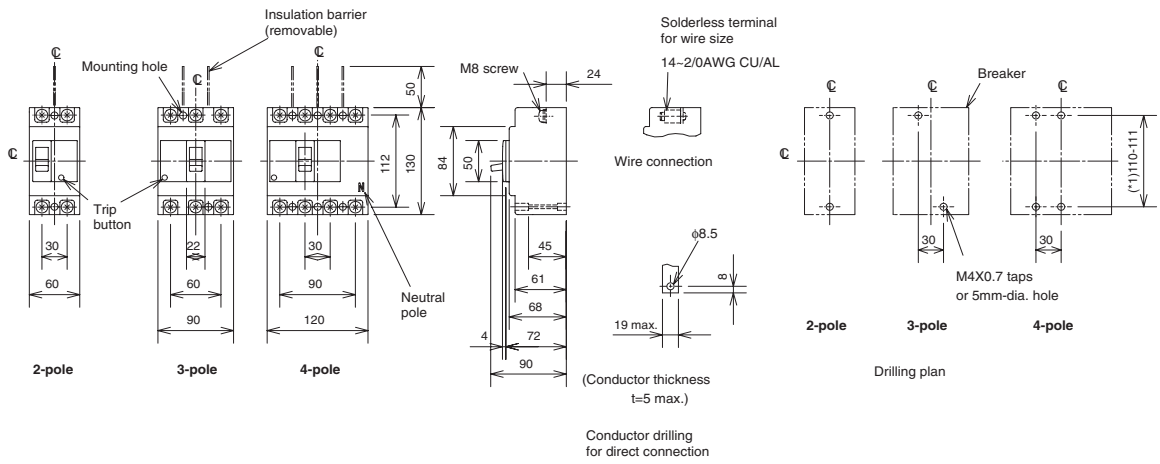

Rear connection

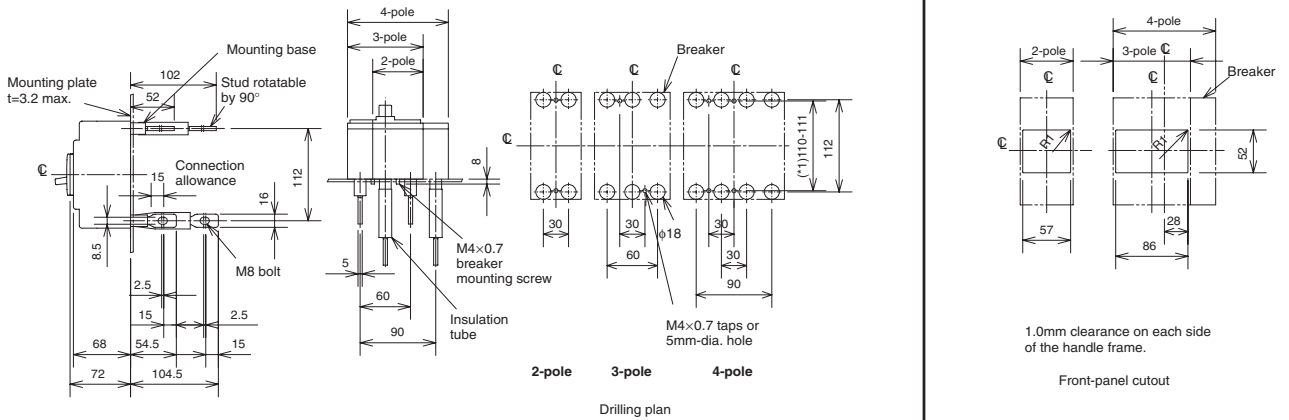

Plug-in

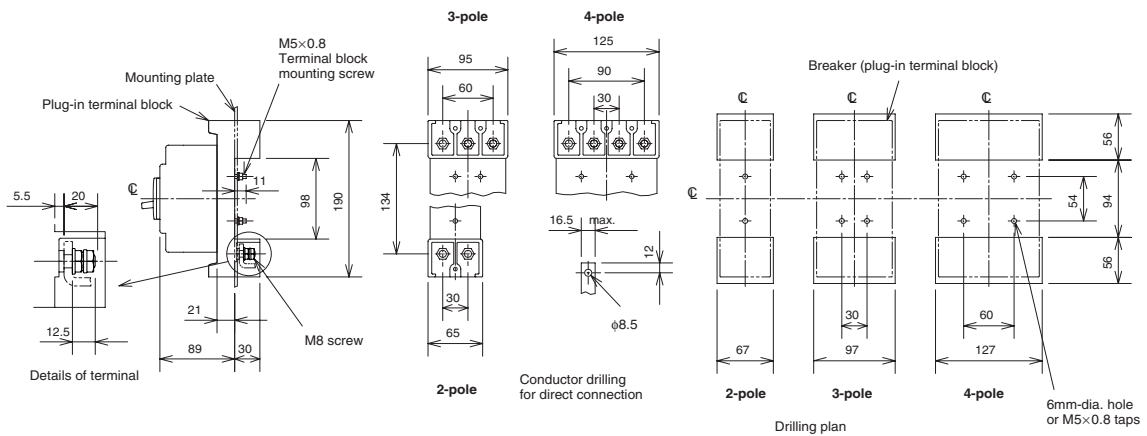

Note (*1) It can respond to the attachment size of 110 and 111 both sides.

Remark: 1. 2-pole model of NF125-HW are 3-pole model with the central pole removed.

6. Characteristics and Dimensions

Molded-Case Circuit Breakers and Motor Breakers

NF250-CW NF250-SW
 NF250-HW NF160-SW
 NF160-HW MB225-SW



Type NF250-SW

Type name	NF160-SW	NF160-HW	NF250-CW	NF250-SW	NF250-HW	MB225-SW								
Rated current In (Amp.)	125 150 160	125 150 160	(100) 125 150 175 200 225 250	(100) 125 150 175 200 225 250	125 150 175 200 225 250	125 150 175 200 225								
Number of poles	2 3 4	2 3 4	2 3	2 3 4	2 3 4	3								
Rated insulation voltage Ui (V)	690	690	600	690	690	500								
Rated short-circuit breaking capacity (kA)	IEC 60947-2 (Icu/Ics)	AC	690V	–	5/3	–	–	5/3	–					
			500V	15/8	30/8	10/5	15/8	30/8	–					
			440V	25/13	50/13	15/8	25/13	50/13	25/13					
			400V	30/15	50/13	18/9	30/15	50/13	30/15					
			230V	50/25	100/25	35/18	50/25	100/25	50/25					
			DC (*1)	250V	15/8	–	40/20	–	10/5	–	15/8	–	40/20	–
				400V	–	15/8	–	40/20	–	–	10/5	–	15/8	–
500V	–	15/8		–	40/20	–	–	15/8	–	40/20	–			
Standard Attached Parts (Front connection)	Mounting screw: M4×0.7×55 (2 and 3P: 2pcs, 4P: 4pcs) Insulation barrier: (2P: 2pcs, 3P: 4pcs, 4P: 6pcs)													

Note (*1) When wired as shown at the bottom of page 13, 3-pole models can be used for up to 400 V DC, and 4-pole models for up to 500 V DC.

Operating Characteristics

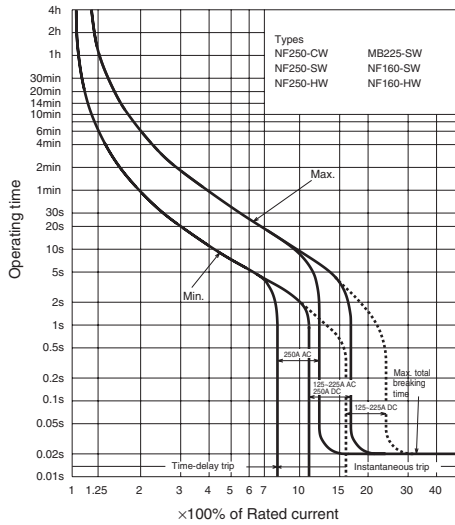

Remark: 1. Only AC characteristics are available for the model MB225-SW.
 2. Refer to page 48.

Ambient Compensating Curve

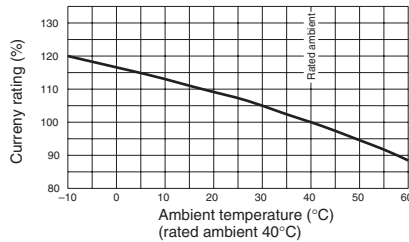

Internal Accessories

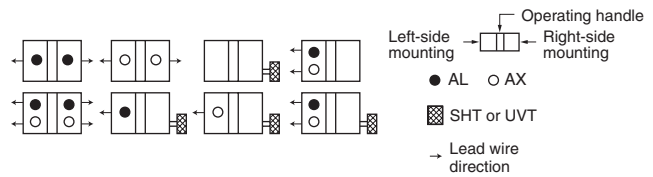

External Accessories

Accessories	Type name	Reference page	Accessories	Type name	Reference page
Operating handle	F F-2S	61	Mechanical interlock	MI MI-05SW3 (*1)	79
	V V-2S	64		Terminal cover	Small TC-S TCS-2SW3W (*1)
	S S2SW	68	Large TC-L TCL-2SW3W (*1)		
Handle lock device	LC LC-2SW	80	Skeleton TTC TTC-2SW3 (*1)		
	(*3) HLF-2SW		Rear BTC BTC-2SW3W (*1)		
	HL HLN-2SW		Plug-in PTC PTC-2SW3W (*1)		
	HL-S HLS-2SW		Electrical operation device	MDS-NF2SWE (*2)	71

Note (*1) The designation depends on the number of poles. Refer to the reference page.
 (*2) Specify the working voltage. An order of MB225-SW should be placed at the same time as an order of circuit breaker main body.
 (*3) HLF types are used for OFF-lock, and HLN types for ON-lock.

Front connection

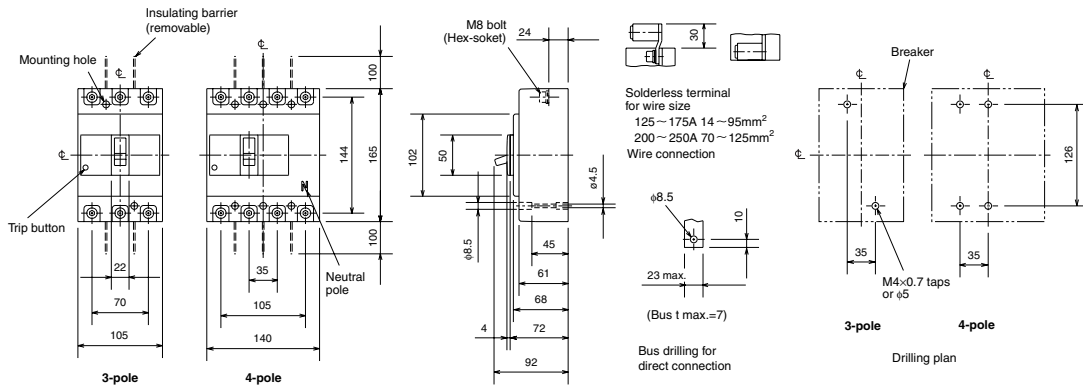

Rear connection

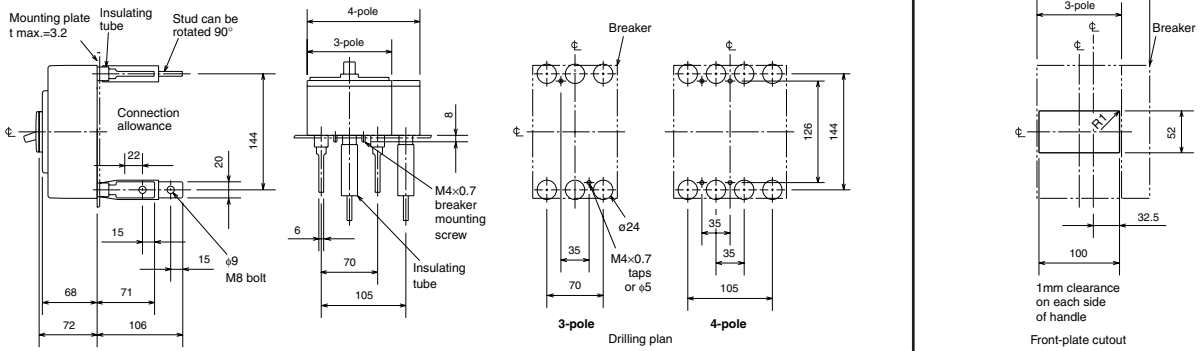

Plug-in

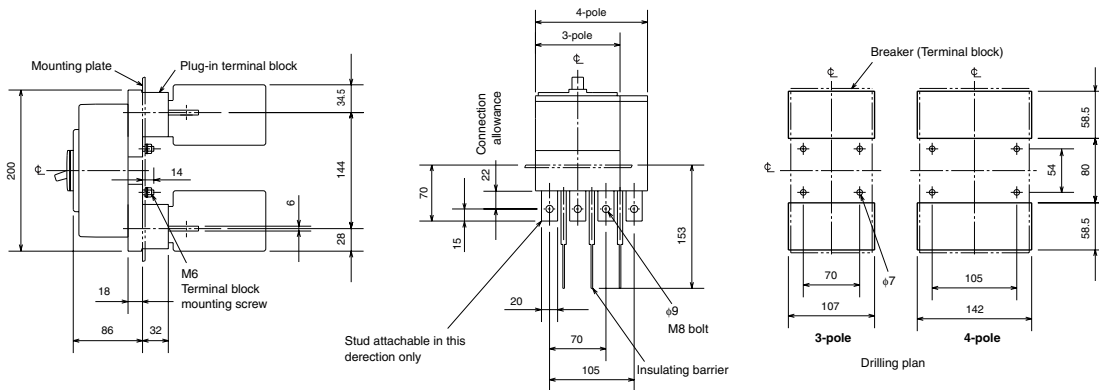

Remark: 1. 2-pole models are 3-pole models with the central pole removed.

2. Only 2- and 3-pole models are available for the model of NF250-CW, and only 3-pole models are available for the model of MB225-SW.

6. Characteristics and Dimensions

Molded-Case Circuit Breakers

NF250-SGW NF250-HGW
NF160-SGW NF160-HGW
NF125-SGW NF125-HGW



Type NF250-SGW

Type name	NF125-SGW RT	NF125-SGW RE	NF125-HGW RT	NF125-HGW RE	NF160-SGW RT	NF160-SGW RE		
Rated current In (Amp.)	16-25, 25-40, 40-63, 63-100, 80-125	16-32, 32-63, 63-100, 75-125	16-25, 25-40, 40-63, 63-100, 80-125	16-32, 32-63, 63-100, 75-125	125-160	80-160		
Number of poles	2 3 4	3 4	2 3 4	3 4	2 3 4	3 4		
Rated insulation voltage Ui (V)	690	690	690	690	690	690		
Rated short-circuit breaking capacity (kA)	AC	690V	8/8	8/8	20/20	20/20	30/30	30/30
		500V	30/30	30/30	50/50	50/50	30/30	30/30
		440V	36/36	36/36	65/65	65/65	36/36	36/36
		400V	36/36	36/36	75/75	75/75	36/36	36/36
		230V	85/85	85/85	100/100	100/100	85/85	85/85
	DC (#1)	300V	20/20	-	40/40	-	20/20	-
		500V	-	20/20	-	40/40	-	20/20
		600V	-	20/20	-	40/40	-	20/20
		600V	-	20/20	-	40/40	-	20/20
		600V	-	40/40	-	20/20	-	40/40
Standard Attached Parts (Front connection)	Mounting screw: M4x0.7x73 (4pcs) Insulation barrier: (2P: 2pcs, 3P: 4pcs, 4P: 6pcs)							

Type name	NF160-HGW RT	NF160-HGW RE	NF250-SGW RT	NF250-SGW RE	NF250-HGW RT	NF250-HGW RE		
Rated current In (Amp.)	125-160	80-160	125-160, 160-250	125-250	125-160, 160-250	125-250		
Number of poles	2 3 4	3 4	2 3 4	3 4	2 3 4	3 4		
Rated insulation voltage Ui (V)	690	690	690	690	690	690		
Rated short-circuit breaking capacity (kA)	AC	690V	20/20	20/20	8/8	8/8	20/20	20/20
		500V	50/50	50/50	30/30	30/30	50/50	50/50
		440V	65/65	65/65	36/36	36/36	65/65	65/65
		400V	75/75	75/75	36/36	36/36	75/75	75/75
		230V	100/100	100/100	85/85	85/85	100/100	100/100
	DC (#1)	300V	40/40	-	20/20	-	40/40	-
		500V	-	40/40	-	20/20	-	40/40
		600V	-	40/40	-	20/20	-	40/40
		600V	-	40/40	-	20/20	-	40/40
		600V	-	40/40	-	20/20	-	40/40
Standard Attached Parts (Front connection)	Mounting screw: M4x0.7x73 (4pcs) Insulation barrier: (2P: 2pcs, 3P: 4pcs, 4P: 6pcs)							

Note (#1) Use either 2-pole. When wired as shown at the bottom of page 13, 3-pole models can be used for up to 500 V DC, and 4-pole models for up to 600V DC.

Operating Characteristics

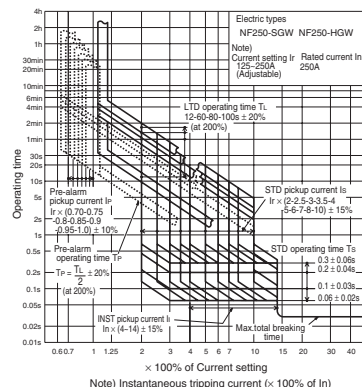
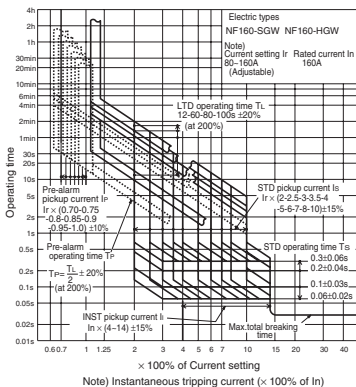
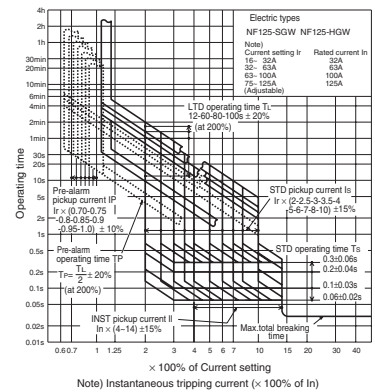
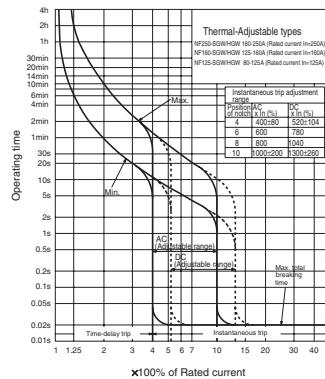
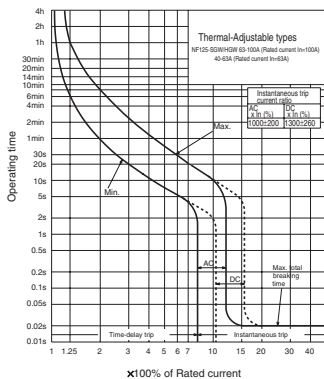
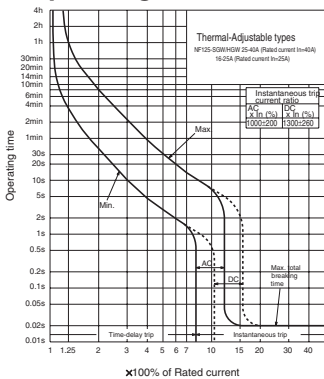

Ambient Compensating Curve

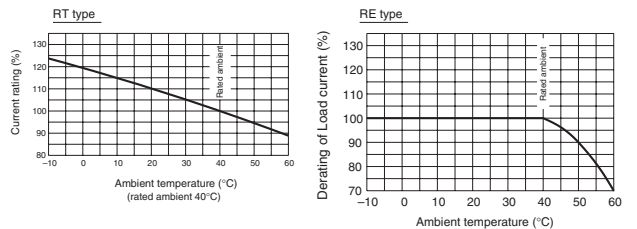

Internal Accessories

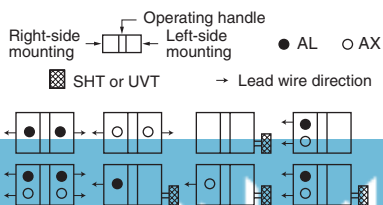

External Accessories

Accessories	Type name	Reference page	Accessories	Type name	Reference page
Operating handle	F	F-2SG	Mechanical interlock	MI	MI-05SW3 (#1)
	V	V-2SG		MI	MI-05SW3 (#1)
	S	S2GSW		MI	MI-05SW3 (#1)
Handle lock device	LC	LC-2GSW	Terminal cover	Small	TC-S
	HL	HLF-2GSW		Large	TC-L
	HL	HLN-2GSW		Skeleton	TTC
	HL-S	HLN-2GSW		Rear	BTC
OFF Lock with 3 Padlock	HLF3-2GSW	80	Plug-in	PTC	PTC-2GSW3W (#1)
Electrical operation device	MDS-NF2GSWE	71			

Note (#1) The designation depends on the number of poles. Refer to the reference page.
 (#2) HLF types are used for OFF-lock, and HLN types for ON-lock.
 (#3) Specify the working voltage.

Remark: 1. Refer to page 48.

Front connection

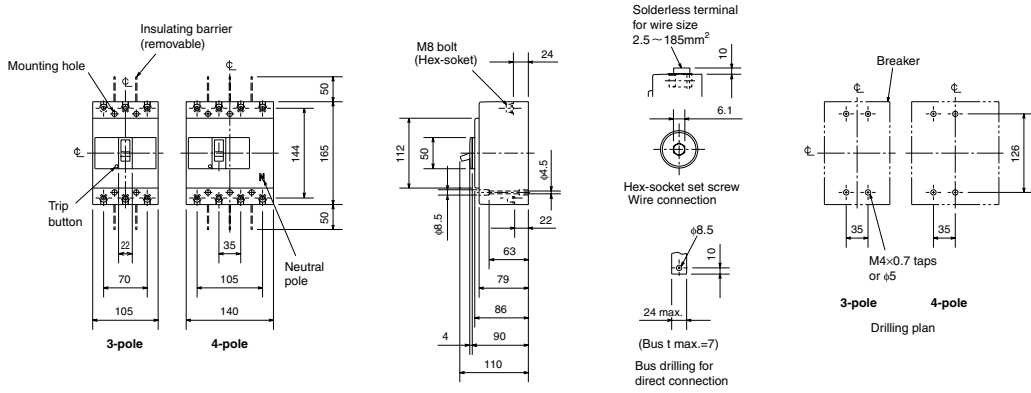

Rear connection

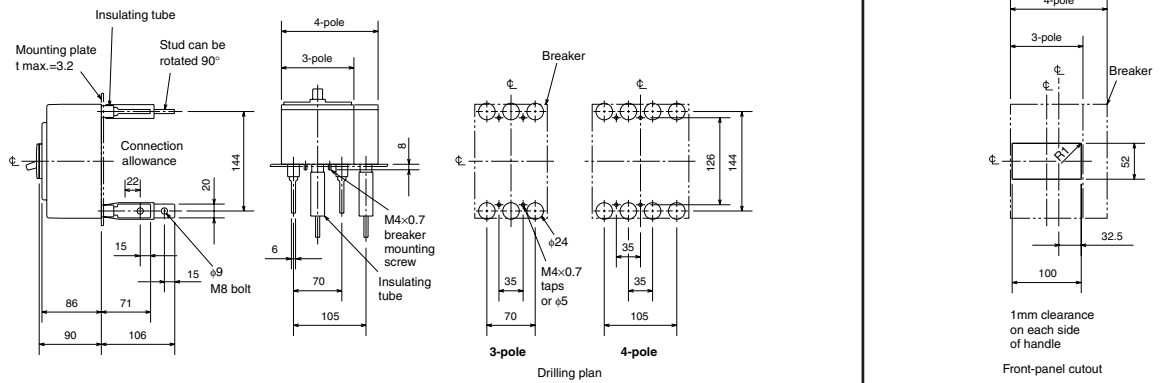

Plug-in

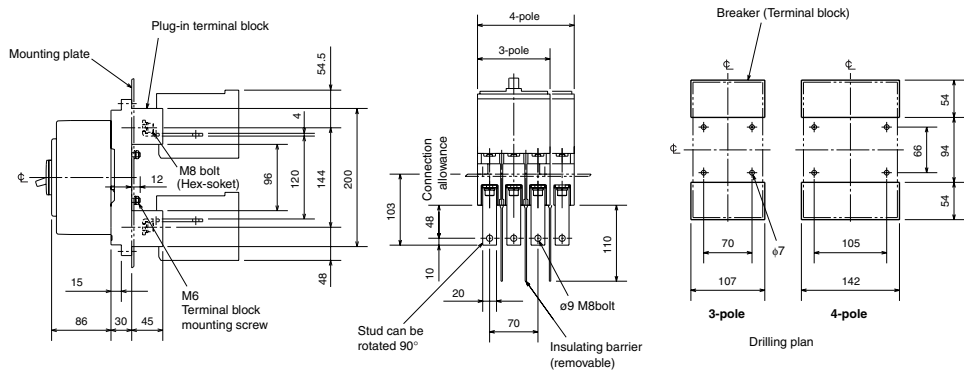

Remark: 1. 2-pole models are 3-pole models with the central pole removed.

6. Characteristics and Dimensions

Molded-Case Circuit Breakers

NF250-RGW NF250-UGW
NF125-RGW NF125-UGW



Type NF250-RGW

Type name	NF125-RGW RT	NF125-UGW RT	NF250-RGW RT	NF250-UGW RT			
Rated current In (Amp.)	16-25 25-40 40-63 63-100	16-25 25-40 40-63 63-100	125-160 160-225	125-160 160-225			
Number of poles	2 3	2 3 4	2 3	2 3 4			
Rated insulation voltage Ui (V)	690		690				
Rated short-circuit breaking capacity (kA)	IEC 60947-2 (Icu/Ics)	AC	690V	25/25	30/30	25/25	30/30
			500V	125/125	200/200	125/125	200/200
			440V	125/125	200/200	125/125	200/200
			400V	125/125	200/200	125/125	200/200
			230V	125/125	200/200	125/125	200/200
		DC	300V	-	-	-	-
500V	-	-	-	-			
600V	-	-	-	-			
Standard Attached Parts (Front connection)	Mounting screw: M4×0.7×73 (4pcs) Insulation barrier: (2P: 2pcs, 3P: 4pcs, 4P: 6pcs)						

Operating Characteristics

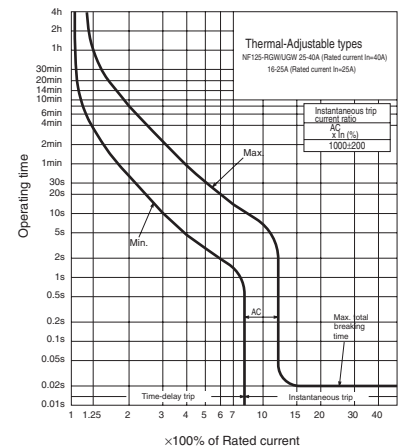
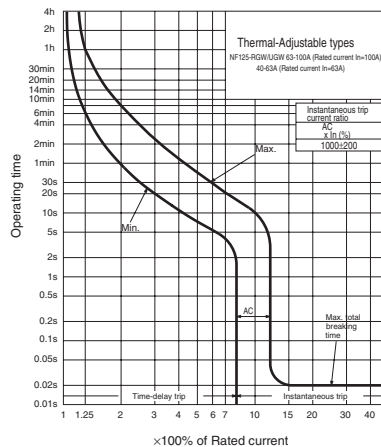
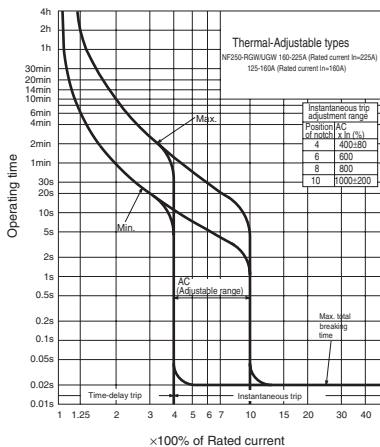

Internal Accessories

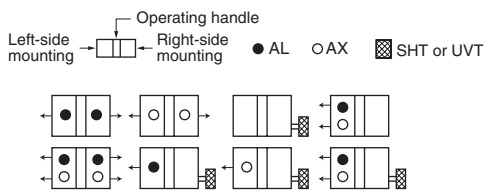

Remark: 1. Refer to page 48.

Ambient Compensating Curve

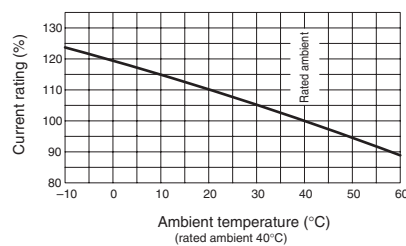

External Accessories

Accessories	Type name	Reference page	Accessories	Type name	Reference page			
Operating handle	F	F-2UG	61	Terminal cover	Small	TC-S	TCS-2GSW3W (*1)	70
	V	V-2UG	64		Large	TC-L	TCL-2GSW3W (*1)	
	S	—	—		Skeleton	TTC	TTC-2GSW3 (*1)	
Mechanical interlock	MI	MI-05SW3 (*1)	79		Rear	BTC	BTC-2GSW3W (*1)	
Electrical operation device	—	—	—		Plug-in	PTC	PTC-2GSW3W (*1)	
Handle lock device	LC	LC-2GSW	80	LC	LC-2GSW			
	(*2) HL	HLF-2GSW						
	HL	HLN-2GSW						
	HL-S	HLS-2GSW						

Note (*1) The designation depends on the number of poles. Refer to the reference page.
(*2) HLF and HLS types are used for OFF-lock, and HLN types for ON-lock.

Front connection

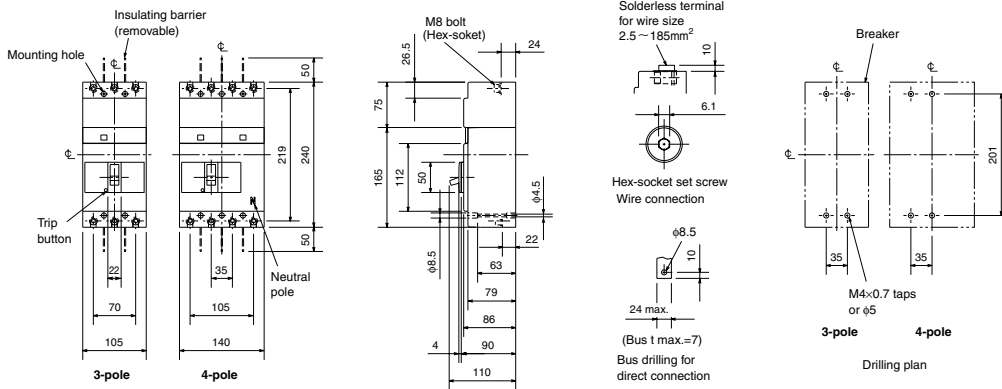

Rear connection

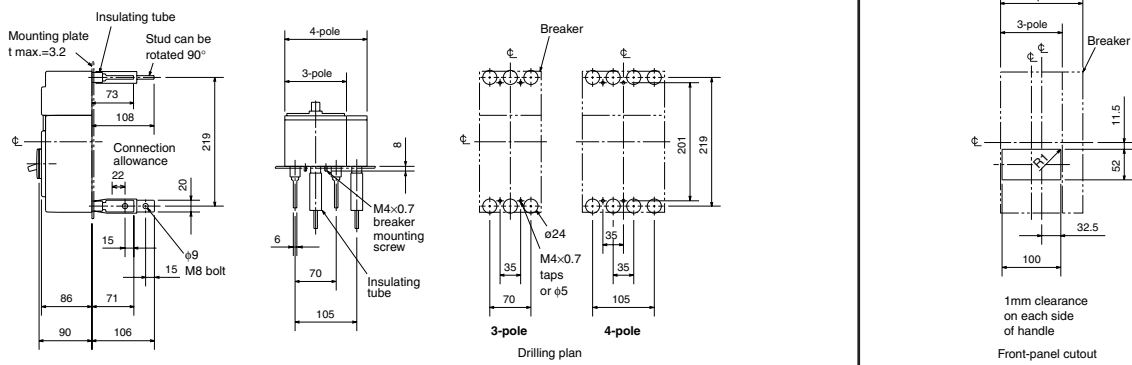

Plug-in

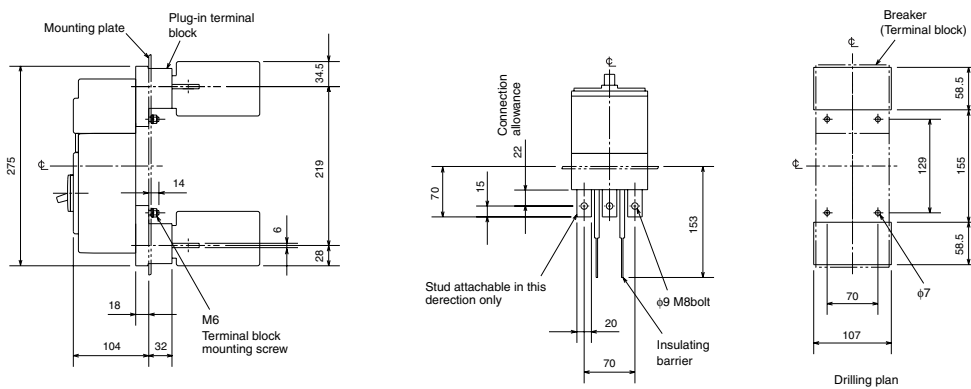

Remark: 1. 2-pole models are 3-pole models with the central pole removed.

6. Characteristics and Dimensions

Molded-Case Circuit Breakers

NF400-CW NF400-SW



Type NF400-SW

Type name		NF400-CW			NF400-SW	
Rated current In (Amp.)		250	300	350	400	
Number of poles		2	3	2	3	4
Rated insulation voltage Ui (V)		690			690	
Rated short-circuit breaking capacity (kA)	IEC 60947-2 (Icu/Ics)	AC	690V	10/10		
			500V	30/30		
			440V	42/42		
		DC(*1)	400V	45/45		
			230V	85/85		
			250V	40/40		
Standard Attached Parts		Front connection: Mounting screw: M6×60 (4pcs) Insulating barrier: (2P: 2pcs, 3P: 4pcs, 4P: 6pcs)				
		Rear connection: Mounting screw: M6×72 (4pcs)				

Note (*1) When wired as shown at the bottom of page 17, 3-pole models can be used for up to 400VDC, and 4-pole models for up to 500VDC.

Operating Characteristics

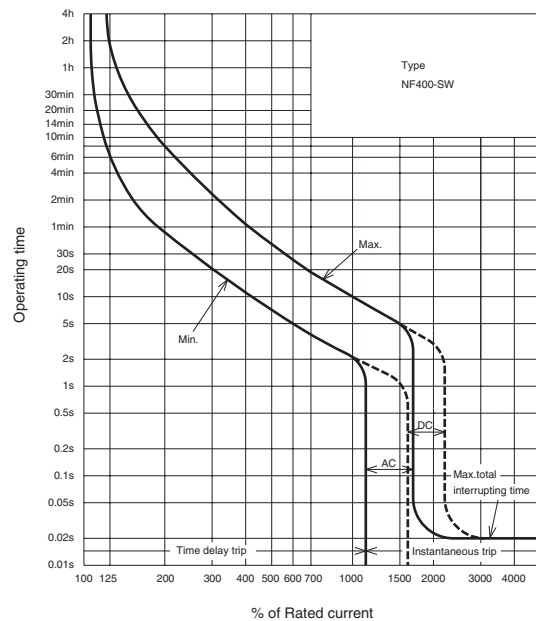
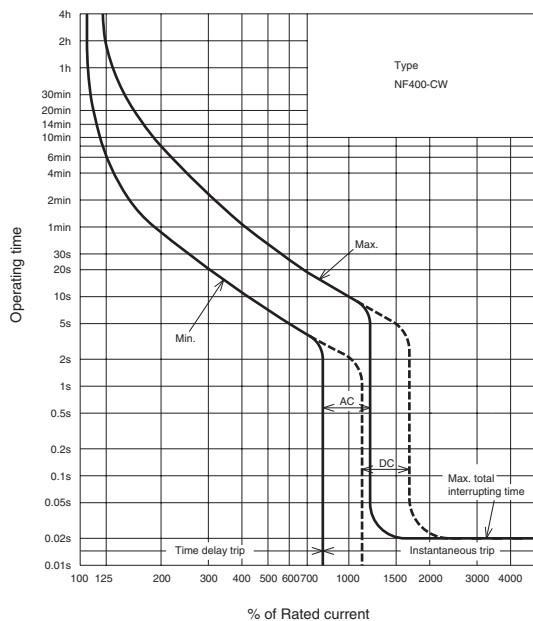

Internal Accessories

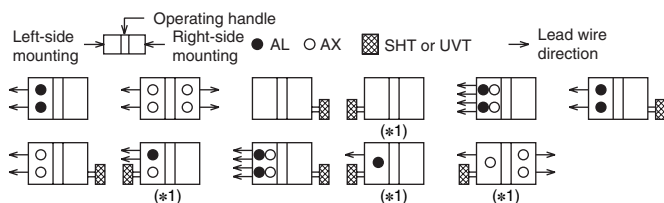

Note (*1) Right-side mounting is standard of SHT and UVT. Specify separately for left-side mounting.
Remark: 1. Refer to page 49.

Ambient Compensating Curve

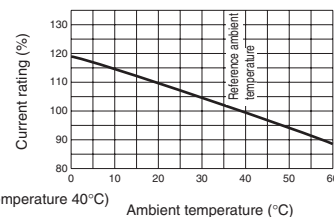

(Reference ambient temperature 40°C)

External Accessories

(An order for ☆ should be placed at the same time as an order of circuit breaker main body.)

Accessories	Type name	Reference page	Accessories	Type name	Reference page
Operating handle	F F-4S	62	Terminal cover	Large (TC-L)	TCL-4SW3 (*1)
	V V-4S	65		Skeleton (TTC)	TTC-4SW3 (*1)
	S S4CW, S4SW	68		Rear (BTC)	BTC-4SW3 (*1)
Mechanical interlock (MI)	MI-4SW3 (*1)	79	Handle lock device	HL	HL-4CW, HL-4SW
Auxiliary handle (HT)	HT-4CW, HT4SW	80		HL-S	HLS-4SW
			Electrical operation device	☆	71

Note (*1) The designation depends on the number of poles. Refer to the reference page.

Front connection

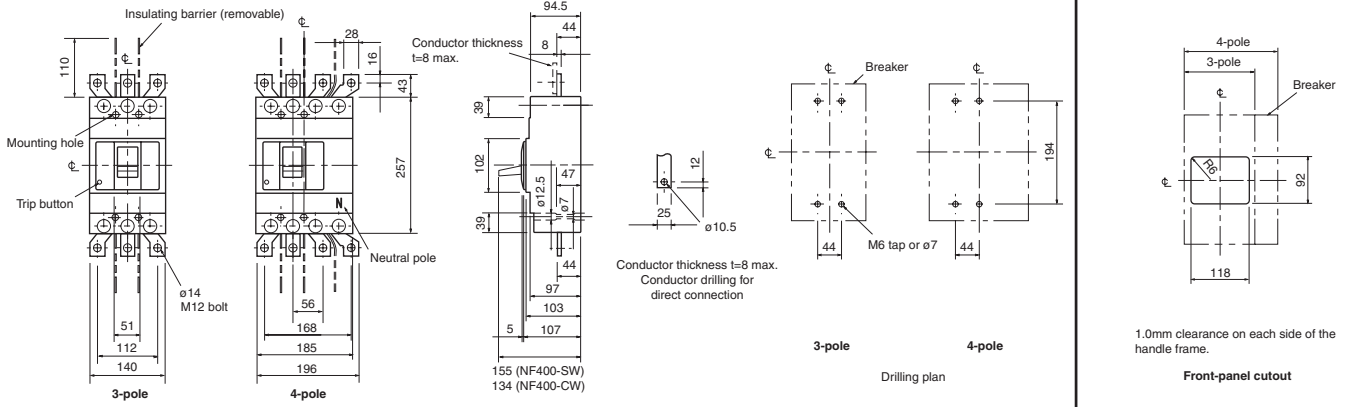

Rear connection

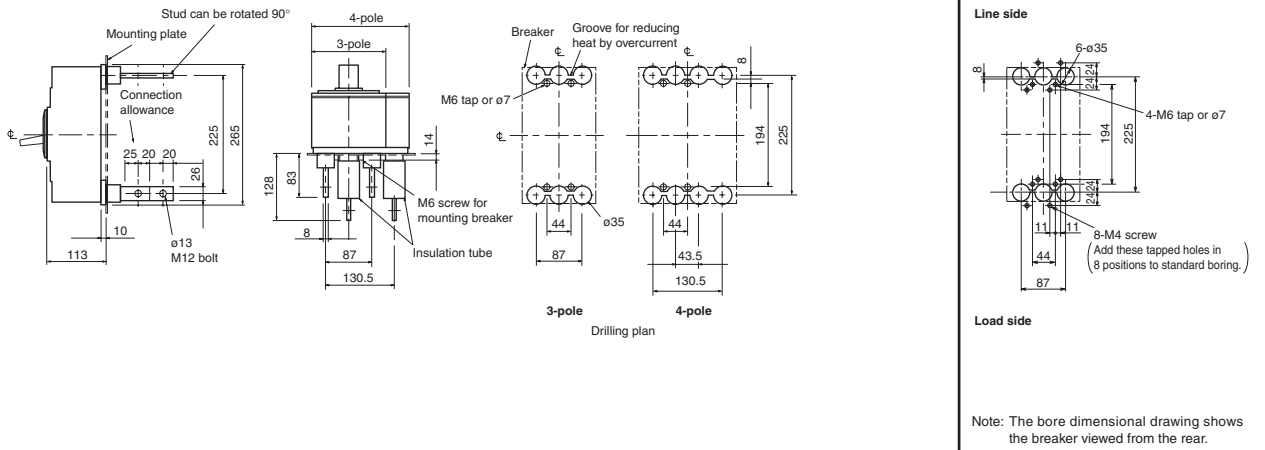

Plug-in

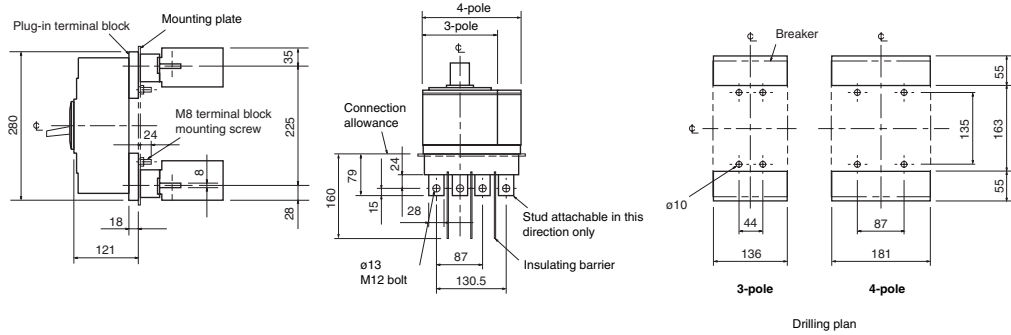

Remark: 1. 2-pole models are 3-pole models with the central pole removed.

6. Characteristics and Dimensions

Molded-Case Circuit Breakers

NF400-SEW
NF400-HEW
NF400-REW



Type NF400-SEW

Type name	NF400-SEW	NF400-HEW	NF400-REW			
Rated current In (Amp.)	200-400 adjustable					
Number of poles	3	4	3			
Rated insulation voltage Ui (V)	690	690	690			
Rated short-circuit breaking capacity (kA)	IEC 60947-2 (Icu/Ics)	AC	690V	10/10	35/18	—
			500V	30/30	50/50	70/35
			440V	42/42	65/65	125/63
			400V	50/50	70/70	125/63
			230V	85/85	100/100	150/75
Standard Attached Parts	Front connection	Mounting screw: M6×72 (4pcs) Insulating barrier: (3P: 4pcs, 4P: 6pcs)				
	Rear connection	Mounting screw: M6×85 (4pcs)				

Operating Characteristics

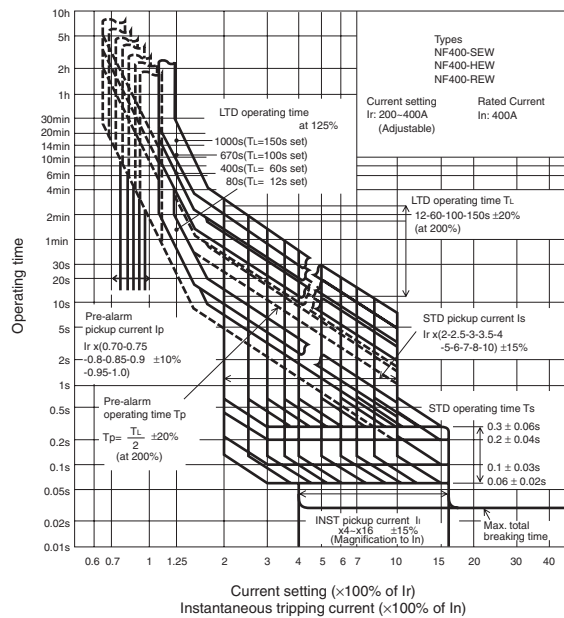

Internal Accessories

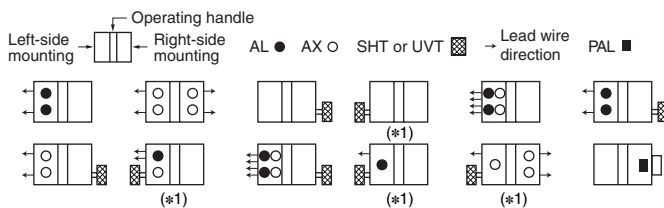

Temperature Characteristics

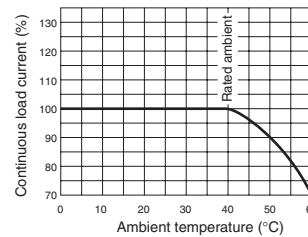

Note (*1) Right-side mounting is standard of SHT and UVT. Specify separately for left-side mounting.
Remark: 1. Refer to page 49.

External Accessories

(An order for ☆ should be placed at the same time as an order of circuit breaker main body.)

Accessories	Type name	Reference page	Accessories	Type name	Reference page
Operating handle	F F-4S	62	Terminal cover	Large (TC-L) TCL-4SW3 (*1)(*2)	70
	V V-4S	65		Skeleton (TTC) TTC-4SW3 (*2)	
	S S4SW	68		Rear (BTC) BTC-4SW3 (*1)(*2)	
Mechanical interlock (MI)	MI-4SW3 (*2)	79	Handle lock device	HL HL-4SW	80
Auxiliary handle (HT)	HT-4SW	80		HL-S HLS-4SW	
Electrical operation device				☆	71

Note (*1) This is for NF400-SEW.

(*2) The designation depends on the number of poles. Refer to the reference page.

Front connection

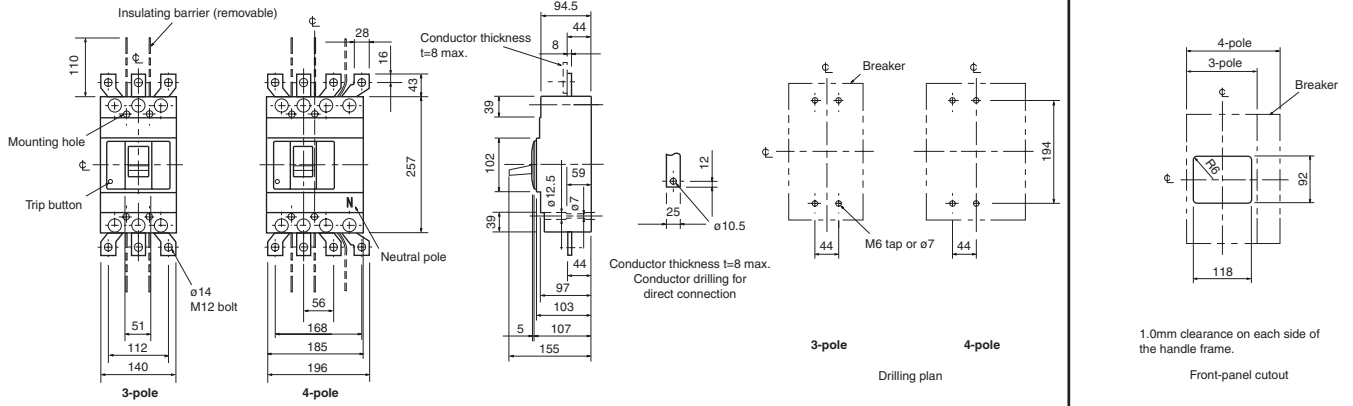

Rear connection

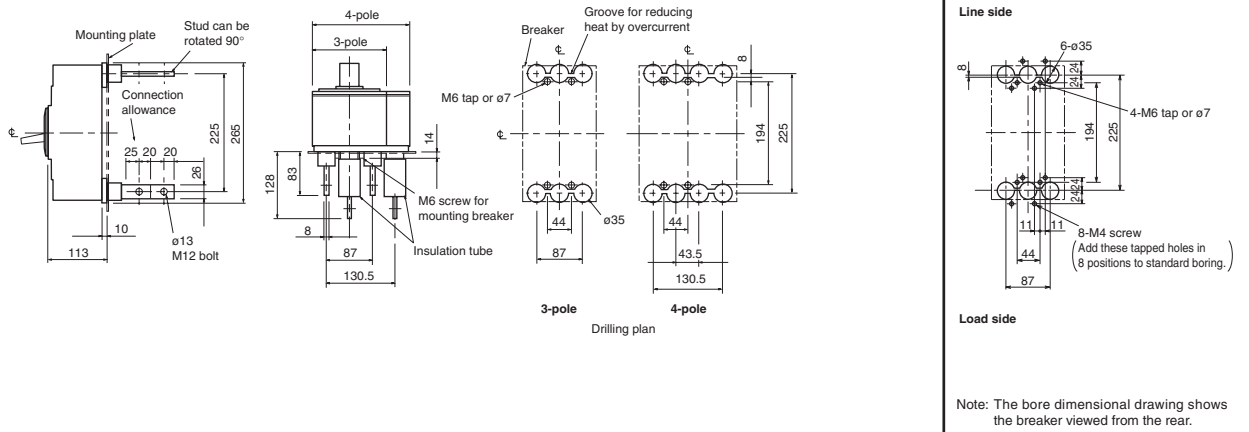

Plug-in

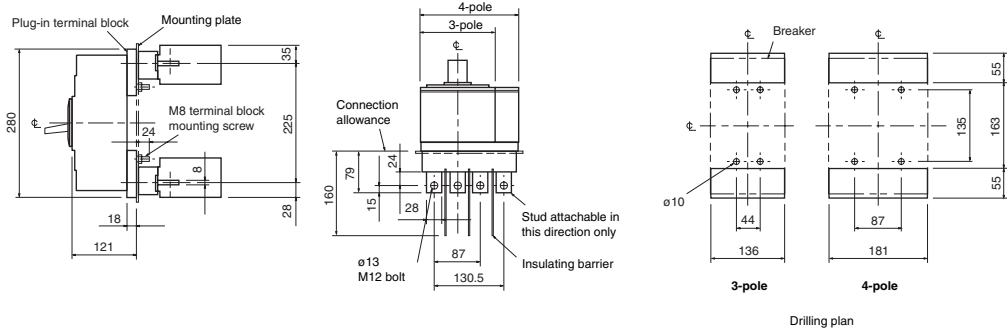

6. Characteristics and Dimensions

Molded-Case Circuit Breakers

NF400-UEW



Type NF400-UEW

Type name		NF400-UEW		
Rated current In (Amp.)		200-400 adjustable		
Number of poles		3	4	
Rated insulation voltage Ui (V)		690		
Rated short-circuit breaking capacity (kA)	IEC 60947-2 (Icu/Ics)	AC	690V	—
			500V	170/170
			440V	200/200
			400V	200/200
			230V	200/200
Standard Attached Parts (4-pole models are provided with auxiliary handle.)		Front connection	Mounting screw: M6×65 (2pcs), M6×174 (2pcs) Insulating barrier: (3P: 4pcs)	
		Rear connection	Mounting screw: M6×72 (2pcs), M6×181 (2pcs)	

Operating Characteristics

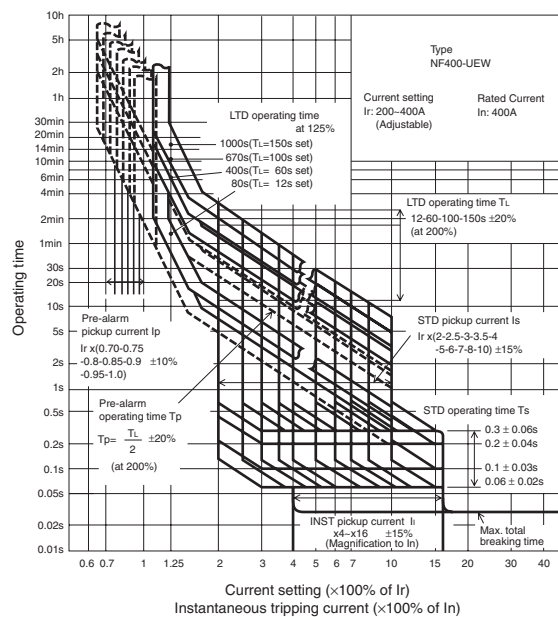

Internal Accessories

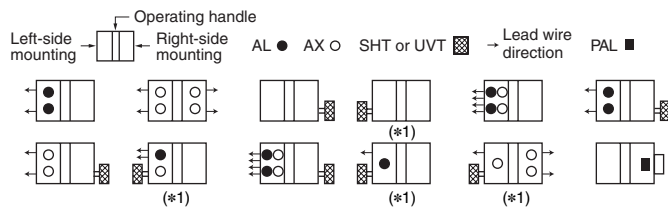

Note (*) Right-side mounting is standard of SHT and UVT. Specify separately for left-side mounting.

Remark: 1. Specification of 4-pole model is same as that of NF800-UEW.
2. Refer to page 107.

Current reducing curve

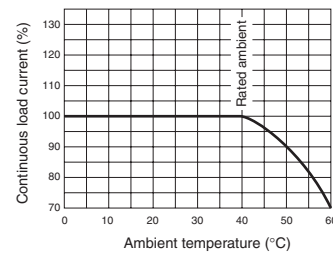

External Accessories

(An order for ☆ should be placed at the same time as an order of circuit breaker main body.)

Accessories	Type name	Reference page	Accessories	Type name	Reference page		
Operating handle	F	F-4U (*)	62	Terminal cover	Large (TC-L)	TCL-4SW3 (*)	70
	S	S4SW	68		Skeleton (TTC)	—	—
Mechanical interlock (MI)	MI-4SW3 (*)	79	Terminal cover	Rear (BTC)	BTC-4SW3 (*)	70	
Auxiliary handle (HT)	HT-4SW	80	Handle lock device	HL	HL-4SW	80	
				HL-S	HLS-4UW		
			Electrical operation device	☆		71	

Note (*) The designation depends on the number of poles. Refer to the reference page.

Front connection

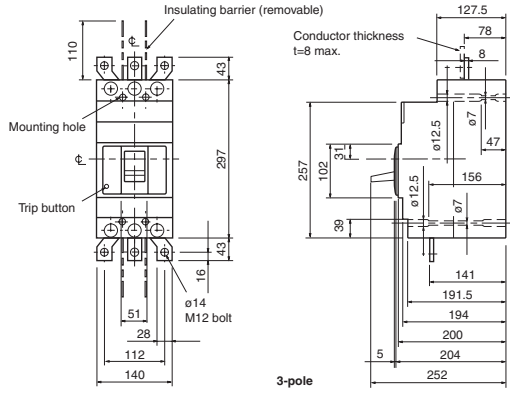

Conductor thickness $t=8$ max.
Conductor drilling for direct connection

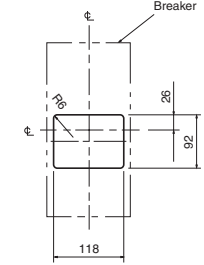
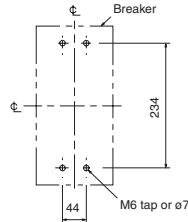

1.0mm clearance on each side of the handle frame.

Front-panel cutout

Rear connection

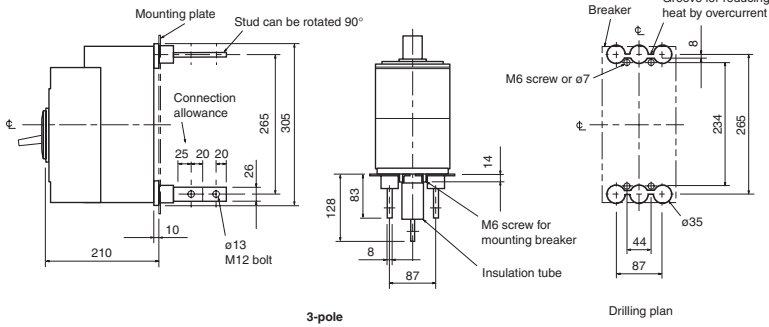

Boring dimensions for rear connection type barriers (3-pole)

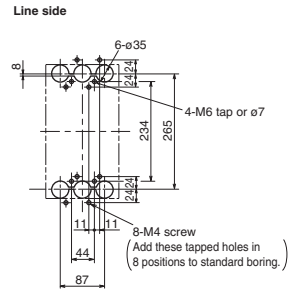

Note: The bore dimensional drawing shows the breaker viewed from the rear.

Plug-in

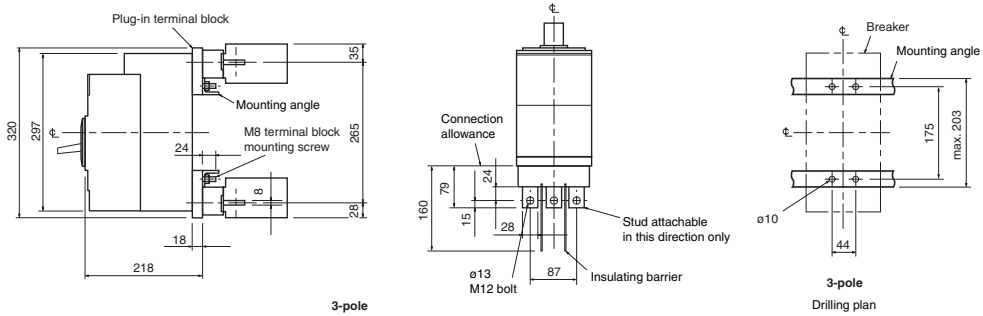

Remark: 1. Overall dimension of 4-pole model is same as that of 4-pole model of NF800-UEW. Refer to page 98.

6. Characteristics and Dimensions

Molded-Case Circuit Breakers

NF630-CW
NF630-SW



Type NF630-SW

Type name		NF630-CW			NF630-SW		
Rated current In (Amp.)		500 600 630					
Number of poles		2	3	2	3	4	
Retard insulation voltage Ui (V)		690					
Rated short-circuit breaking capacity (kA)	IEC 60947-2 (Icu/Ics)	AC	690V	-			10/10
			500V	18/9			30/30
			440V	36/18			42/42
		DC (*1)	400V	36/18			50/50
			230V	50/25			85/85
			250V	20/10			40/40
Standard Attached Parts (4-pole models are provided with auxiliary handle.)		Front connection	Mounting screw: M6×72 (4pcs) Insulating barrier: (2P: 2pcs, 3P: 4pcs, 4P: 6pcs)				
		Rear connection	Mounting screw: M6×85 (4pcs)				

Note (*1) When wired as shown at the bottom of page 17, 3-pole models can be used for up to 400VDC, and 4-pole models for up to 500VDC.

Operating Characteristics

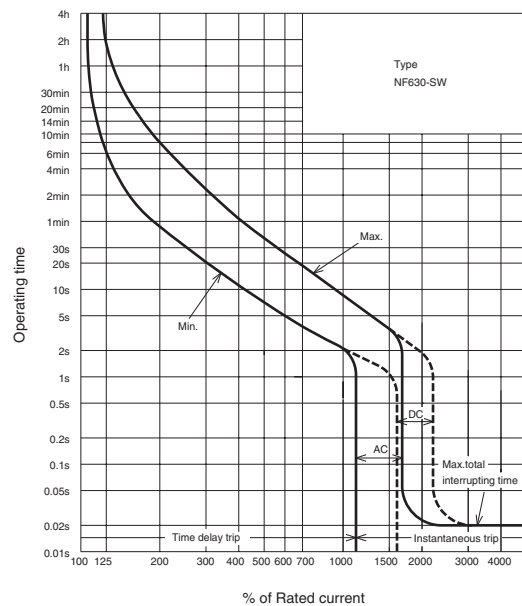
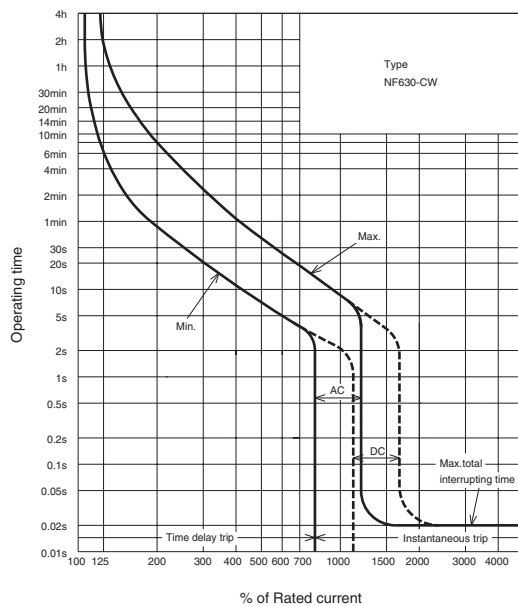

Internal Accessories

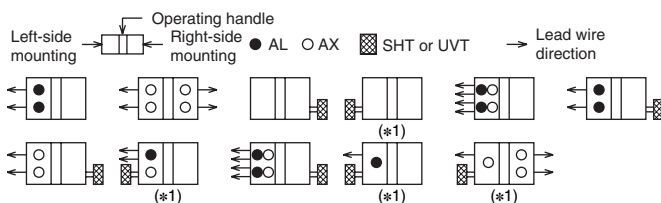

Note (*1) Right-side mounting is standard of SHT and UVT. Specify separately for left-side mounting.
Remark: 1. Refer to page 49.

Ambient Compensating Curve

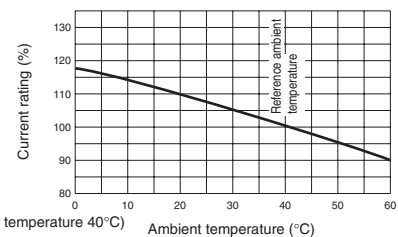

(Reference ambient temperature 40°C)

External Accessories

(An order for ☆ should be placed at the same time as an order of circuit breaker main body.)

Accessories	Type name	Reference page	Accessories	Type name	Reference page
Operating handle	F F-4S	62	Terminal cover	Large (TC-L)	TCL-4SW3 (*1)
	V V-4S	65		Skeleton (TTC)	TTC-4SW3 (*1)
	S S4SW	68		Rear (BTC)	BTC-4SW3 (*1)
Mechanical interlock (MI)	MI-4SW3 (*1)	79	Handle lock device	HL	HL-4SW
Auxiliary handle (HT)	HT-4SW	80		HL-S	HLS-4SW
			Electrical operation device	☆	71

Note (*1) The designation depends on the number of poles. Refer to the reference page.

Front connection

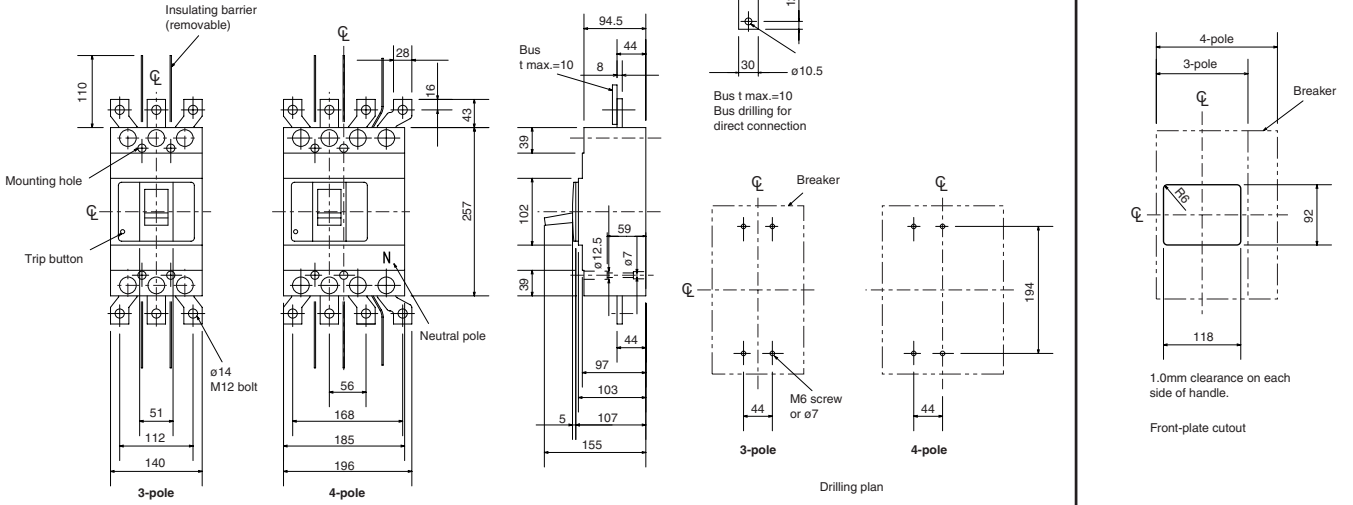

Rear connection

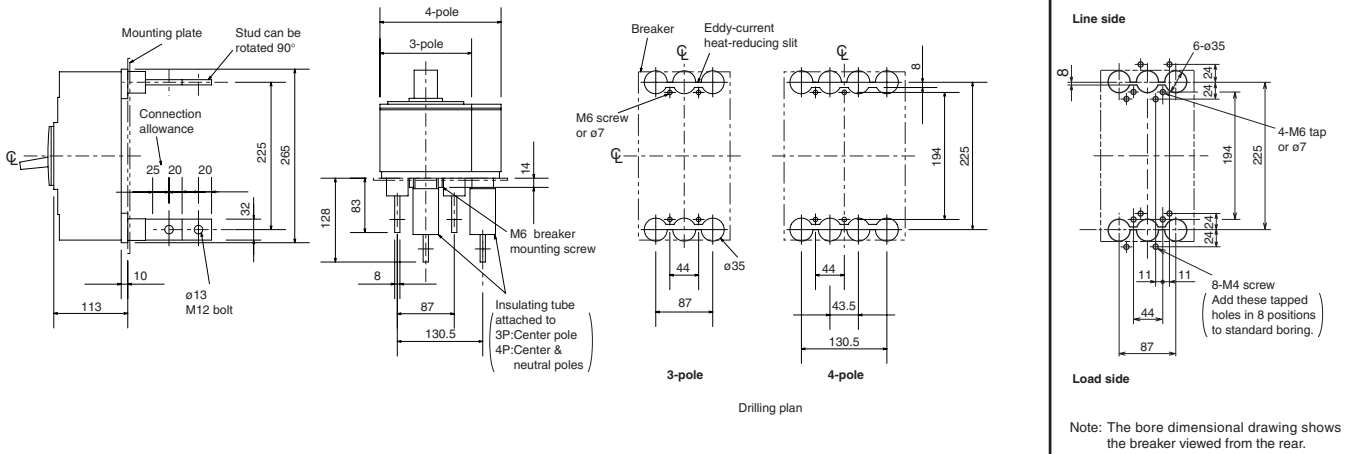

Plug-in

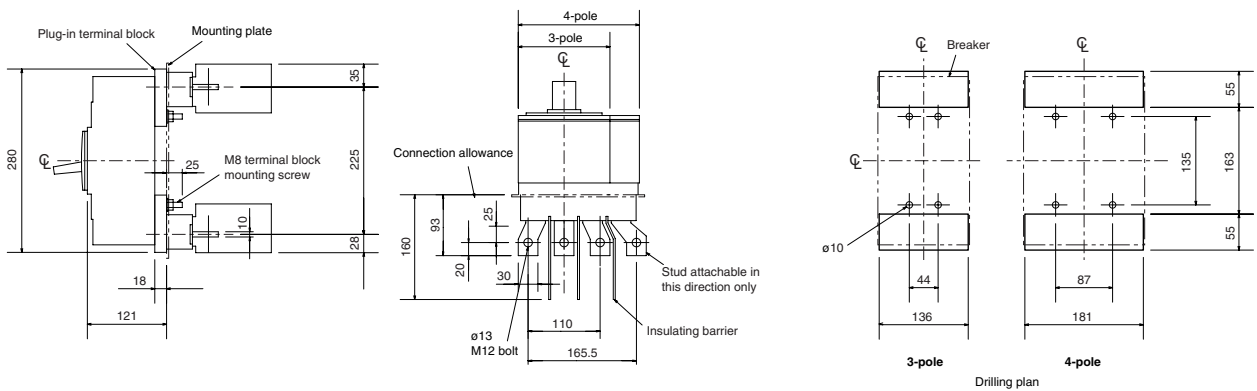

Remark: 1. 2-pole models are 3-pole models with the central pole removed.

6. Characteristics and Dimensions

Molded-Case Circuit Breakers

NF630-SEW
NF630-HEW
NF630-REW



Type NF630-SEW

Type name		NF630-SEW	NF630-HEW	NF630-REW		
Rated current In (Amp.)		300-630 adjustable				
Number of poles		3	4	3		
Rated insulation voltage Ui (V)		690	690	690		
Rated short-circuit breaking capacity (kA)	IEC 60947-2 (Icu/Ics)	AC	690V	10/10	35/18	—
			500V	30/30	50/50	70/35
			440V	42/42	65/65	125/63
			400V	50/50	70/70	125/63
			230V	85/85	100/100	150/75
Standard Attached Parts (4-pole models are provided with auxiliary handle.)		Front connection: Mounting screw: M6×72 (4pcs) Insulating barrier: (3P: 4pcs, 4P: 6pcs)				
		Rear connection: Mounting screw: M6×85 (4pcs)				

Operating Characteristics

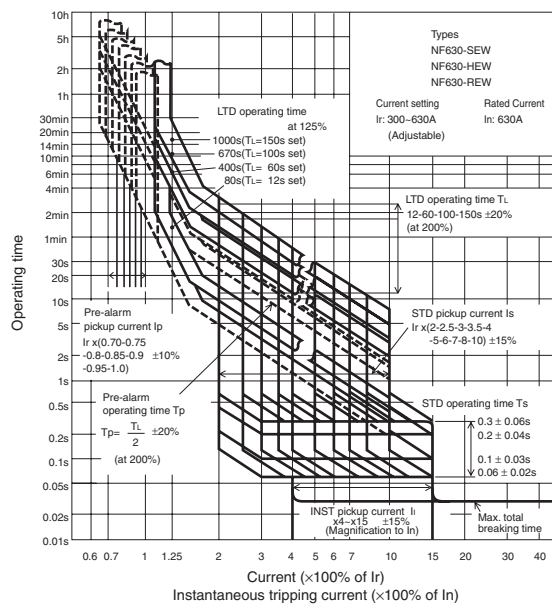

Internal Accessories

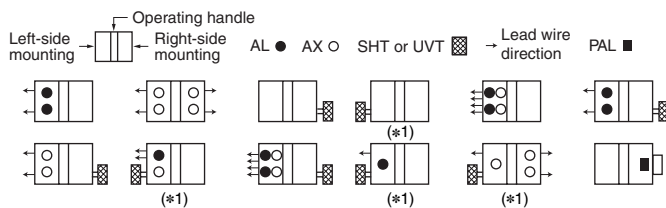

Temperature Characteristics

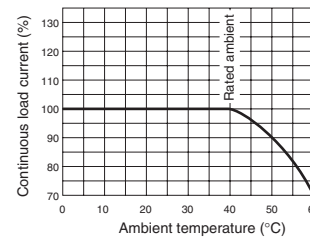

Note (*1) Right-side mounting is standard of SHT and UVT. Specify separately for left-side mounting.
Remark: 1. Refer to page 49.

External Accessories

(An order for ☆ should be placed at the same time as an order of circuit breaker main body.)

Accessories	Type name	Reference page	Accessories	Type name	Reference page
Operating handle	F F-4S	62	Terminal cover	Large (TC-L) TCL-4SW3 (*2)	70
	V V-4S	65		Skeleton (TTC) TTC-4SW3 (*2)	
	S S4SW	68		Rear (BTC) BTC-4SW3 (*2)	
Mechanical interlock (MI)	MI-4SW3 (*1)	79	Handle lock device	HL HL-4SW	80
Auxiliary handle (HT)	HT-4SW	80		HL-S HLS-4SW	
			Electrical operation device	☆	71

Note (*1) This is for NF630-SEW

(*2) The designation depends on the number of poles. Refer to the reference page.

Front connection

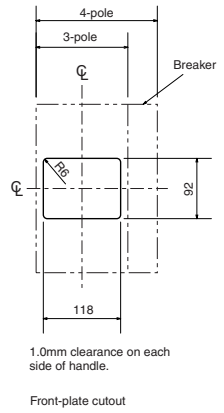
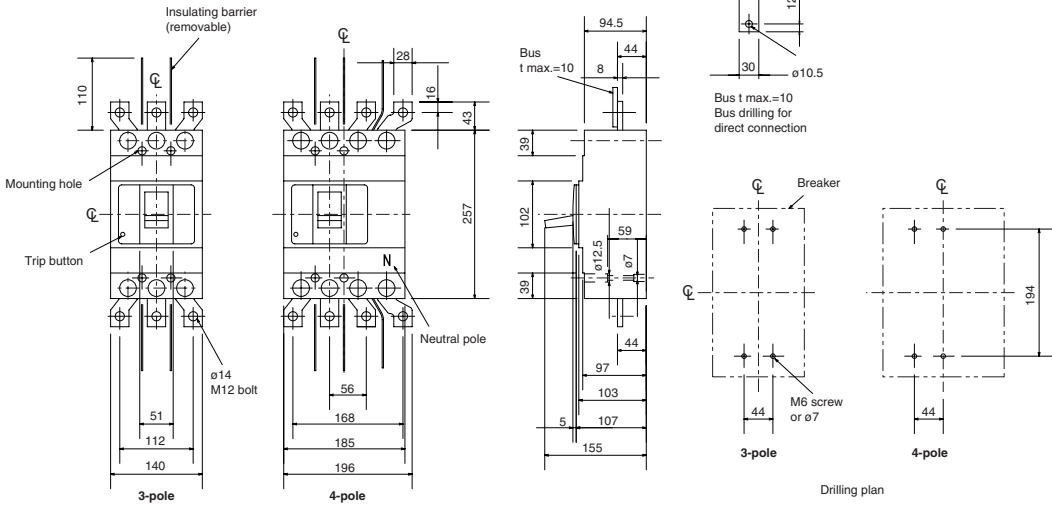

Rear connection

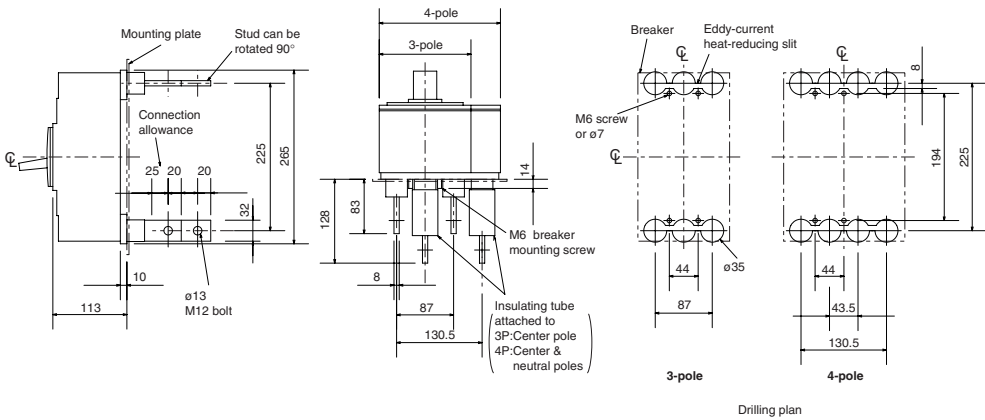

Boring dimensions for rear connection type barriers (3-pole)

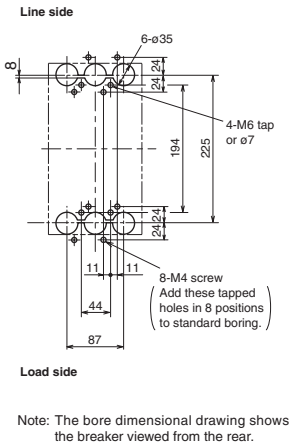

Plug-in

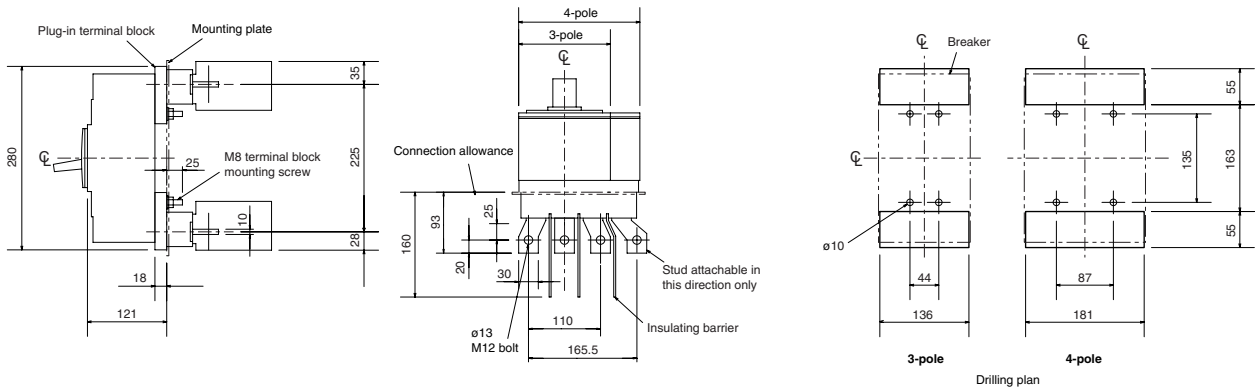

6. Characteristics and Dimensions

Molded-Case Circuit Breakers

NF800-CEW
NF800-SEW
NF800-HEW
NF800-REW



Type NF800-SEW

Type name	NF800-CEW	NF800-SEW	NF800-HEW	NF800-REW			
Rated current In (Amp.)	400-800 adjustable						
Number of poles	3	3	4	3			
Rated insulation voltage Ui (V)	690	690	690	690			
Rated short-circuit breaking capacity (kA)	IEC 60947-2 (Icu/Ics)	AC	690V	—	10/10	15/15	—
			500V	18/9	30/30	50/50	70/35
			440V	36/18	42/42	65/65	125/63
			400V	36/18	50/50	70/70	125/63
			230V	50/25	85/85	100/100	150/75
Standard Attached Parts (4-pole models are provided with auxiliary handle.)	Front connection	Mounting screw: M6×35 (4pcs) Insulating barrier: (3P: 2pcs, 4P: 3pcs)					
	Rear connection	Mounting screw: M6×40 (4pcs)					

Operating Characteristics

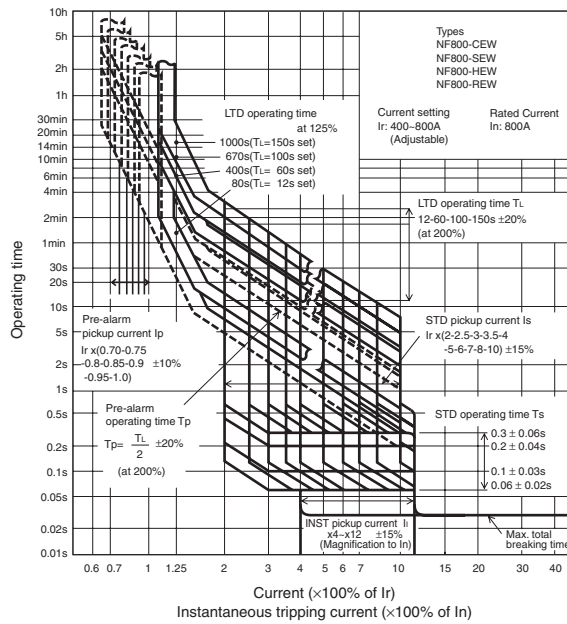

Internal Accessories

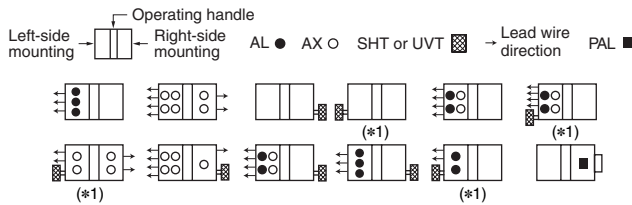

Current Reducing Curve

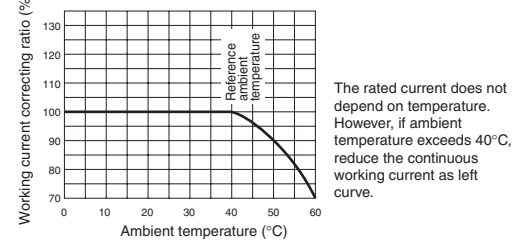

Note (*1) Right-side mounting is standard of SHT and UVT. Specify separately for left-side mounting.
Remark: 1. Refer to page 49.

External Accessories

(An order for ☆ should be placed at the same time as an order of circuit breaker main body.)

Accessories	Type name	Reference page	Accessories	Type name	Reference page
Operating handle	F F-8S	62	Terminal cover	Large (TC-L) TCL-8SW3 (*1)	70
	V V-8S	65		Skeleton (TTC) TTC-8SW3 (*1)	
	S S4SW	68		Rear (BTC) BTC-8SW3 (*1)	
Mechanical interlock (MI)	MI-8SW3 (*1)	79	Handle lock device	HL HL-4SW	80
Auxiliary handle (HT)	HT-4SW	80		HL-S HLS-8SW	
			Electrical operation device	☆	71

Note (*1) The designation depends on the number of poles. Refer to the reference page.

Front connection

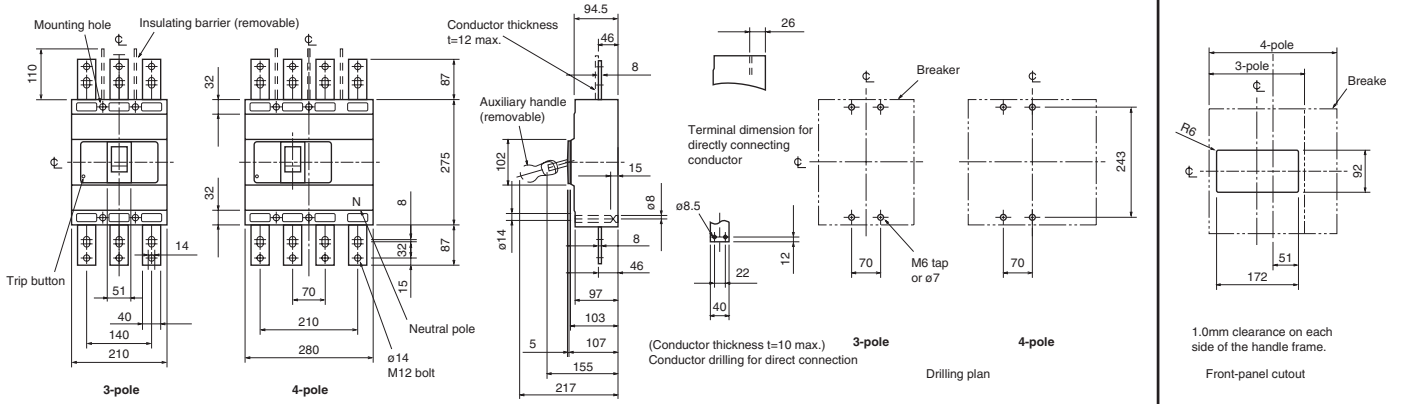

Rear connection

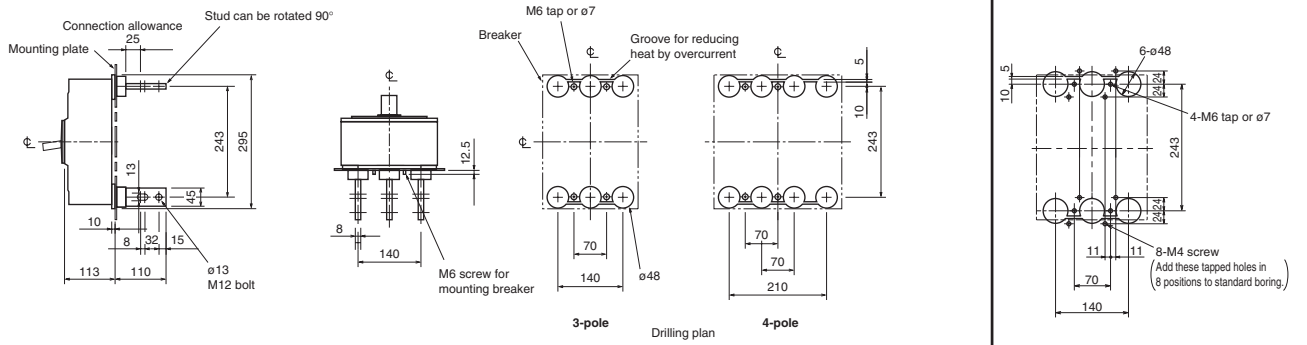

Plug-in

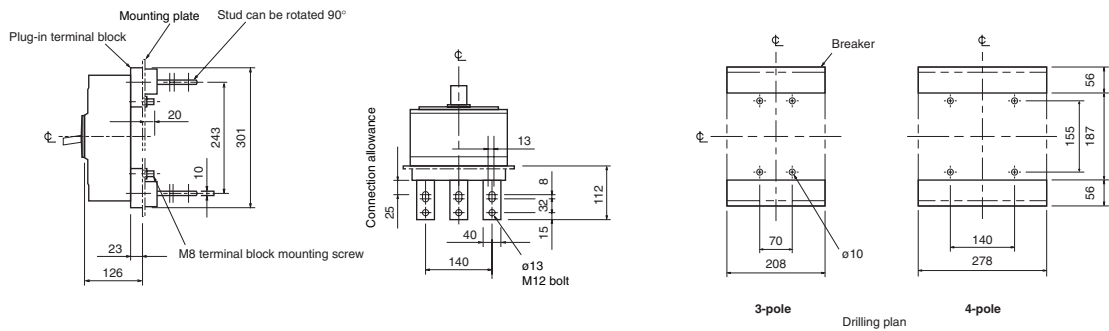

6. Characteristics and Dimensions

Molded-Case Circuit Breakers

NF800-SDW



Type NF800-SDW

Type name		NF800-SDW	
Rated current In (Amp.)		(700), 800	
Number of poles		2	
Rated insulation voltage Ui (V)		690	
Rated short-circuit breaking capacity (kA)	IEC 60947-2 (Icu/Ics)	DC	250V
	Time constant not larger than 10ms		
Standard Attached Parts (4-pole models are provided with auxiliary handle.)	Front connection	Mounting screw: M6×35 (4pcs) Insulating barrier: (2P: 1pc, 3P: 2pcs, 4P: 3pcs)	
	Rear connection	Mounting screw: M6×40 (4pcs)	

Operating Characteristics

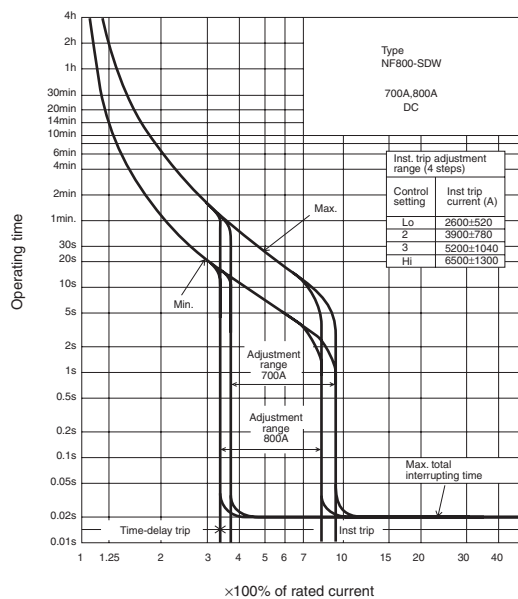

Internal Accessories

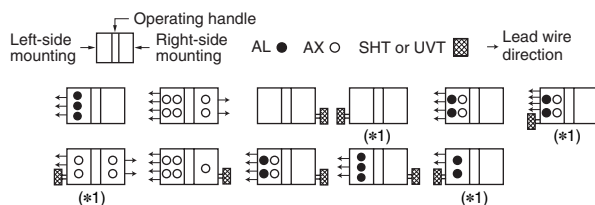

Note (*1) Right-side mounting is standard of SHT and UVT. Specify separately for left-side mounting.
Remark: 1. Refer to page 49.

Ambient Compensating Curve

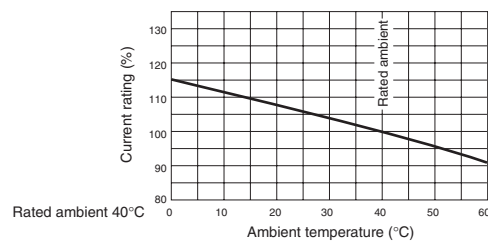

External Accessories

(An order for ☆ should be placed at the same time as an order of circuit breaker main body.)

Accessories	Type name	Reference page	Accessories	Type name	Reference page	
Operating handle	F F-8S	62	Terminal cover	Large (TC-L) TCL-8SW3 (*1)	70	
	V V-8S	65		Skeleton (TTC) TTC-8SW3 (*1)		
	S S4SW	68		Rear (BTC) BTC-8SW3 (*1)		
Mechanical interlock (MI)	MI-8SW3 (*1)	79	Handle lock device	HL HL-4SW	80	
Auxiliary handle (HT)	HT-4SW	80		HL-S HLS-8SW		
				Electrical operation device	☆	71

Note (*1) The designation depends on the number of poles. Refer to the reference page.

Front connection

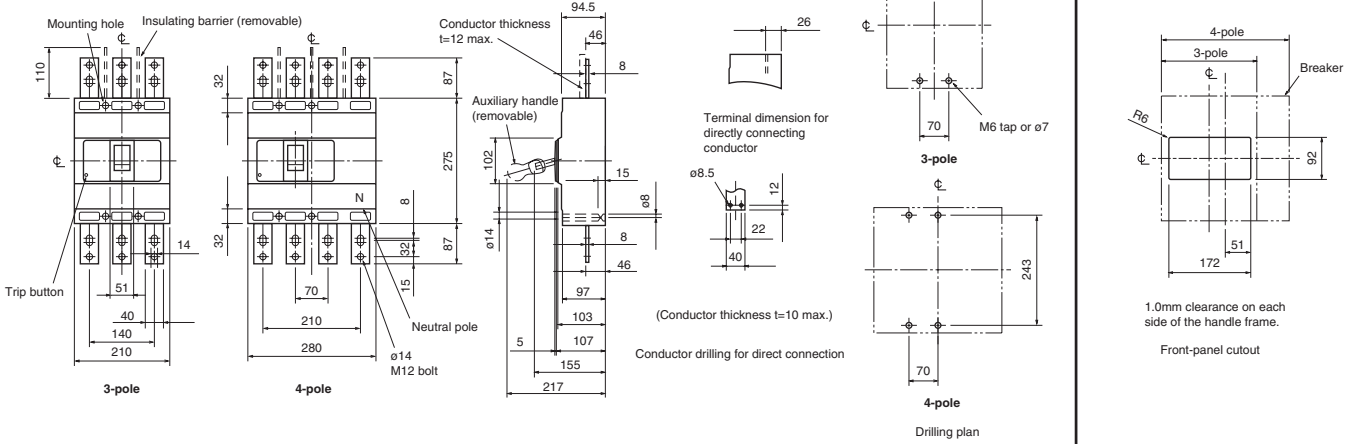

Rear connection

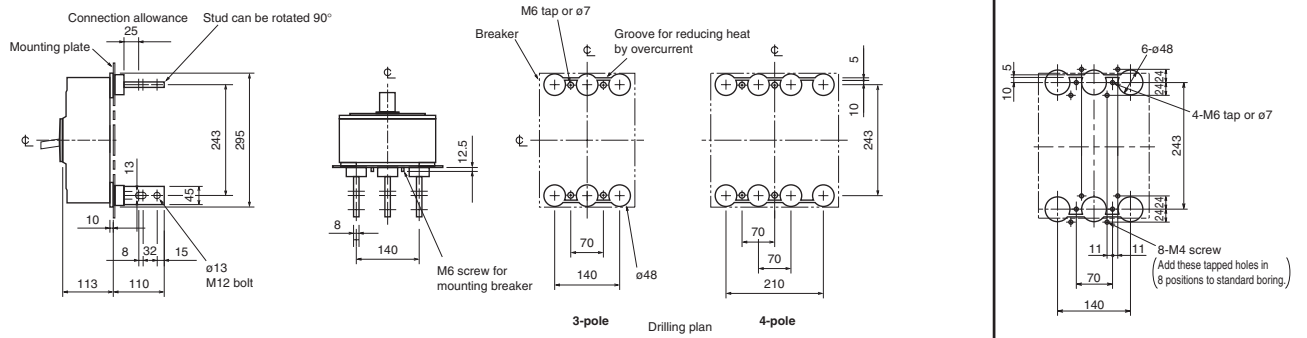

Plug-in

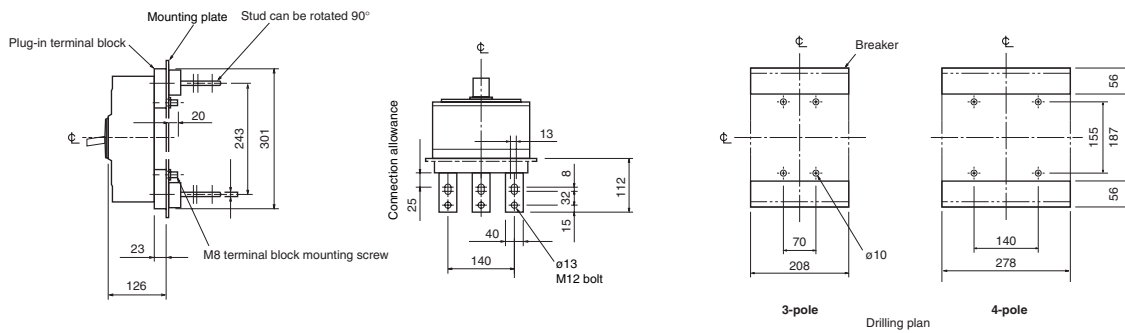

Remark: 1. Standard specification of NF800-SDW is 2-pole model. 3-pole and 4-pole models are available for DC special voltage.
2. 2-pole models are 3-pole models with the central pole removed.

6. Characteristics and Dimensions

Molded-Case Circuit Breakers

NF800-U EW



Type NF800-U EW

Type name		NF800-U EW		
Rated current I_n (Amp.)		400-800 adjustable		
Number of poles		3	4	
Rated insulation voltage U_i (V)		690		
Rated short-circuit breaking capacity (kA)	IEC 60947-2 (Icu/Ics)	AC	690V	35/35
			500V	170/170
			440V	200/200
			400V	200/200
			230V	200/200
Standard Attached Parts (4-pole models are provided with auxiliary handle.)	Front connection	Mounting screw: 3P: M6×35, M6×132 (2pcs each) 4P: M6×35 (3pcs), M6×132 (2pcs) Insulating barrier: (3P: 2pcs, 4P: 3pcs)		
	Rear connection	Mounting screw: 3P: M6×40, M6×137 (2pcs each) 4P: M6×40 (3pcs), M6×137 (2pcs)		

Operating Characteristics

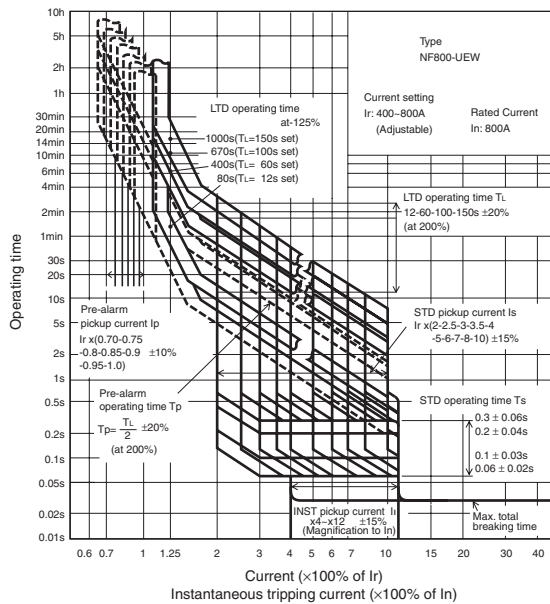

Internal Accessories

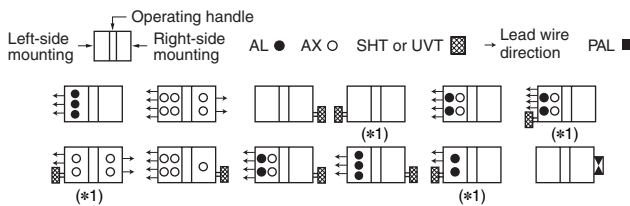

Note (*) Right-side mounting is standard of SHT and UVT. Specify separately for left-side mounting.
Remark: 1. Refer to page 49.

Current reducing curve

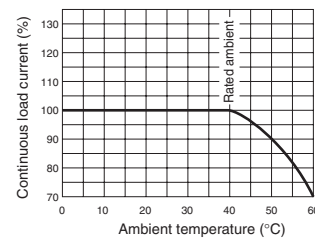

External Accessories

(An order for ☆ should be placed at the same time as an order of circuit breaker main body.)

Accessories	Type name	Reference page	Accessories	Type name	Reference page	
Operating handle	F	F-8U(*)	62	Terminal cover	Large (TC-L) TCL-8UW3 (*)	70
	V	—	—	Skeleton (TTC)	—	—
	S	S4SW	68	Rear (BTC)	BTC-8SW3 (*)	70
Mechanical interlock (MI)	MI-8SW3 (*)	79	Handle lock device	HL	HL-4SW	80
Auxiliary handle (HT)	HT-4SW	80		HL-S	HLS-8UW	
			Electrical operation device	☆	71	

Note (*) The designation depends on the number of poles. Refer to the reference page.

Front connection

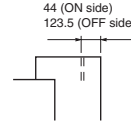
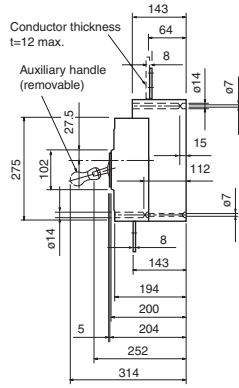
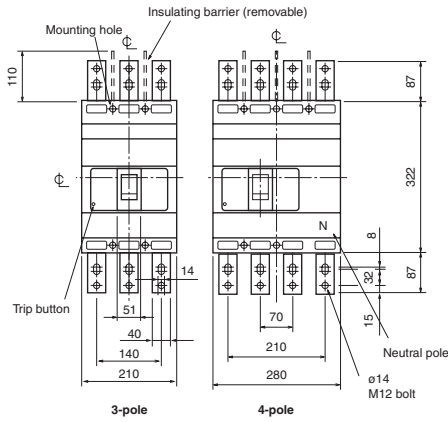

(Conductor thickness $t=10$ max.)

Conductor drilling for direct connection

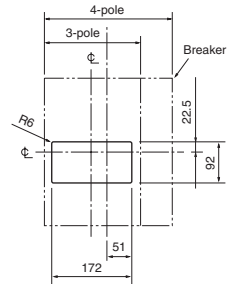

1.0mm clearance on each side of the handle frame.

Front-panel cutout

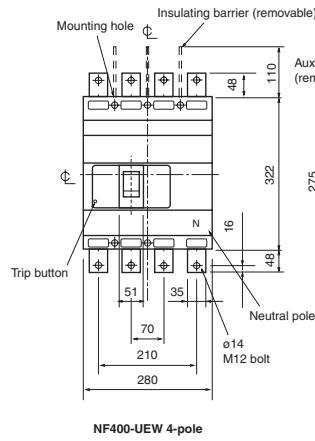
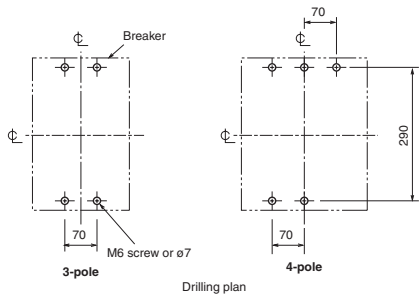

Rear connection

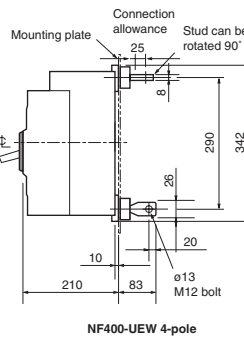
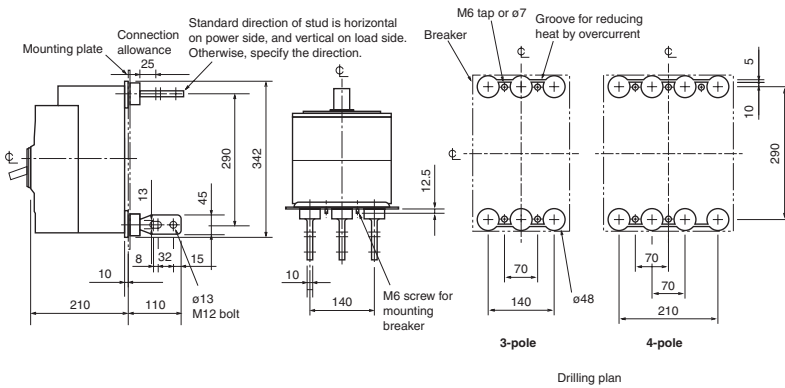

Boring dimensions for rear connection type barriers (3-pole)

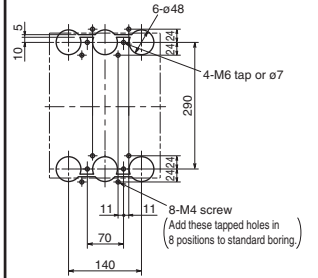

6. Characteristics and Dimensions

Molded-Case Circuit Breakers

NF1000-SEW
NF1250-SEW



Type NF1250-SEW

Type name		NF1000-SEW	NF1250-SEW		
Rated current In (Amp.)		500–1000 Adjustable	600–1250 Adjustable		
Number of poles		3 4	3 4		
Rated insulation voltage Ui (V)		690			
Rated short-circuit breaking capacity (kA)	IEC 60947-2 (Icu/Ics)	AC	690V	25/13	25/13
			500V	65/33	65/33
			440V	85/43	85/43
			400V	85/43	85/43
			230V	125/63	125/63
Standard Attached Parts		Front connection Mounting screw: M8×40 (4pcs) Insulating barrier: (3P: 2pcs, 4P: 3pcs) Auxiliary handle: (1pc)			
		Rear connection Mounting screw: M8×40 (4pcs) Insulating barrier: (3P: 2pcs, 4P: 4pcs) Auxiliary handle: (1pc)			

Operating Characteristics

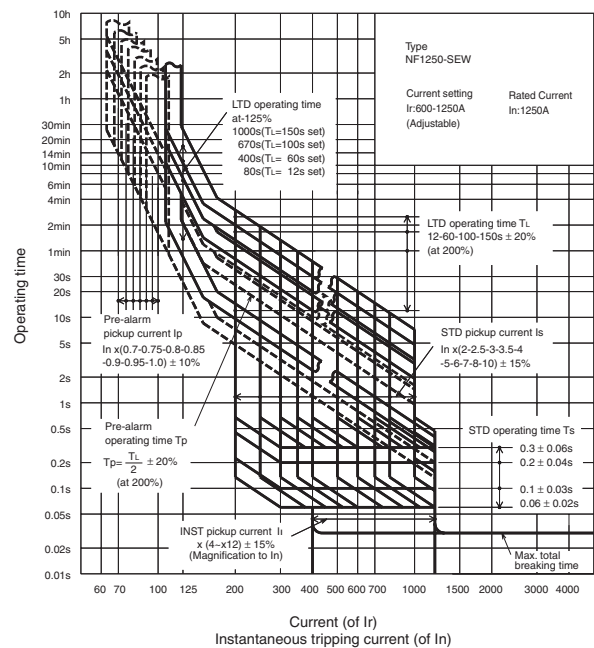
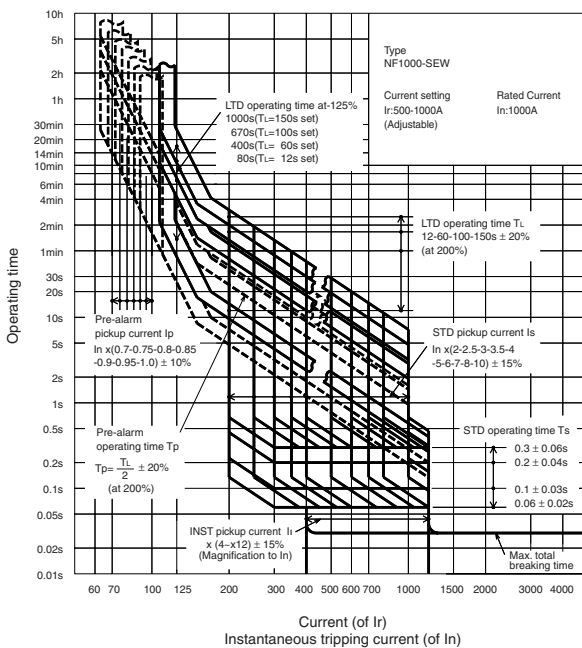

Internal Accessories

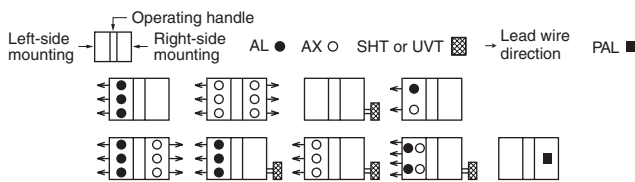

Remark: 1. Refer to page 49.

Current reduction curve

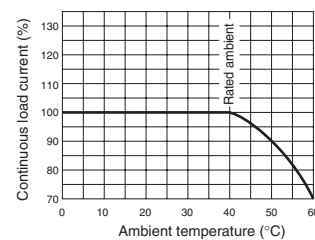

External Accessories

(An order for ☆ should be placed at the same time as an order of circuit breaker main body.)

Accessories	Type name	Reference page	Accessories	Type name	Reference page
Operating handle	F	F10SW (*1)	Auxiliary handle	HT-10SW	80
	S	S10SW		Handle lock (HL)	
Mechanical interlock (MI)	MI-10SW3 (*1)	79	Large terminal cover (TC-L)	TCL-10SW3 (*1)	70
			Electrical operation device	☆	71

Note (*1) The designation depends on the number of poles. Refer to the reference page.

Front connection

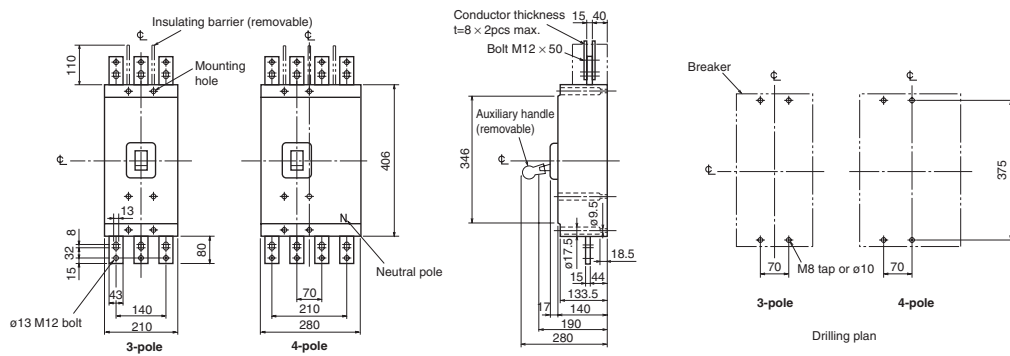

Rear connection

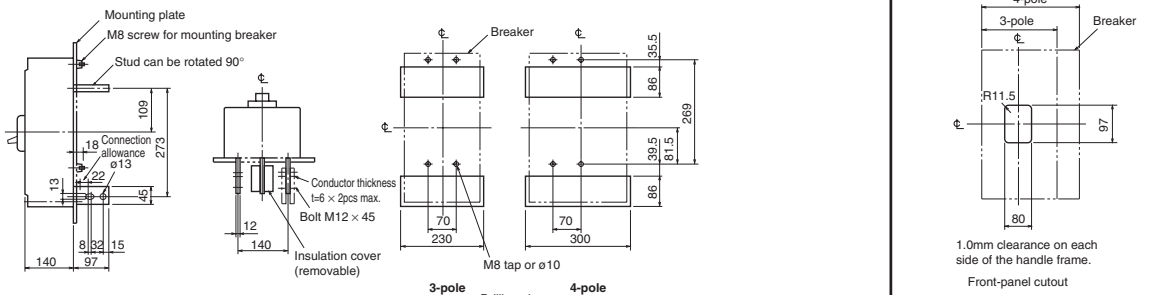

Plug-in

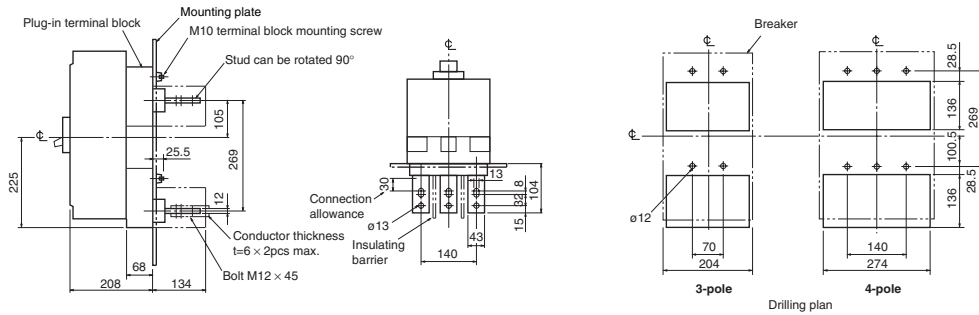

6. Characteristics and Dimensions

Molded-Case Circuit Breakers

NF1250-SDW



Type NF1250-SDW

Type name		NF1250-SDW	
Rated current In (Amp.)		1000, 1250	
Number of poles		2	
Rated insulation voltage Ui (V)		690	
Rated short-circuit breaking capacity (kA) IEC 60947-2 (Icu/Ics) Time constant not larger than 10ms	DC	250V	40/20
Standard Attached Parts	Front connection	Mounting screw: M8 x 40 (4pcs) Insulating barrier: (2P: 1pc, 3P: 2pcs, 4P: 3pcs) Auxiliary handle: (1pc)	
	Rear connection	Mounting screw: M8 x 40 (4pcs) Insulating cover: (3P: 2pcs, 4P: 4pcs) Auxiliary handle: (1pc)	

Operating Characteristics

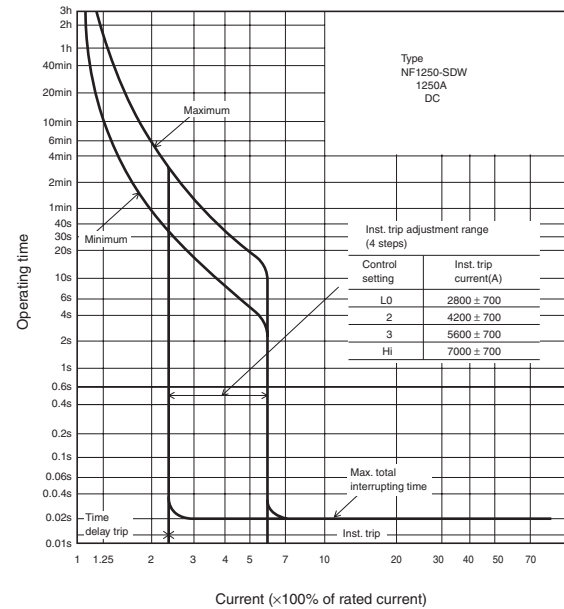
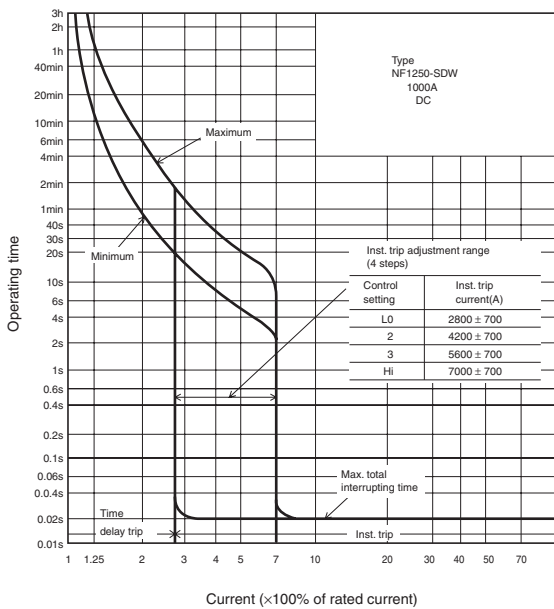

Internal Accessories

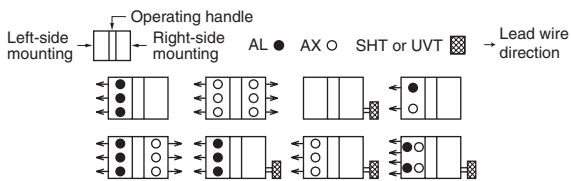

Remark: 1. Refer to page 49.

Ambient Compensating Curve

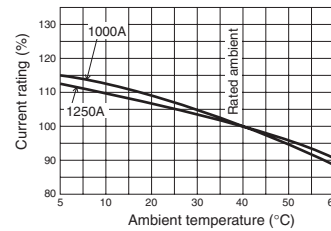

External Accessories

(An order for ☆ should be placed at the same time as an order of circuit breaker main body.)

Accessories	Type name	Reference page	Accessories	Type name	Reference page
Operating handle	F	F10SW (*1)	Auxiliary handle	HT-10SW	80
	S	S10SW	Handle lock (HL)	☆	
Mechanical interlock (MI)	MI-10SW3 (*1)	79	Large terminal cover (TC-L)	TCL-10SW3 (*1)	70
			Electrical operation device	☆	71

Note (*1) The designation depends on the number of poles. Refer to the reference page.

Front connection

Outside dimensions are same as those of NF1000-SEW and NF1250-SEW.

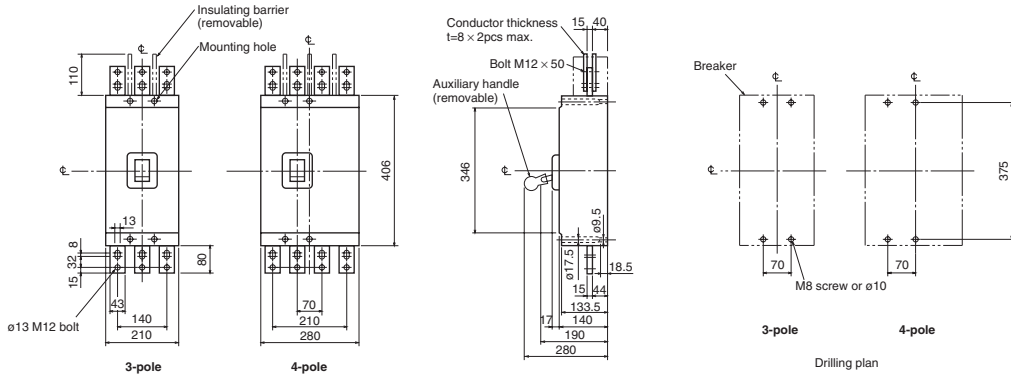

Rear connection

Outside dimensions are different from those of NF1000-SEW and NF1250-SEW.

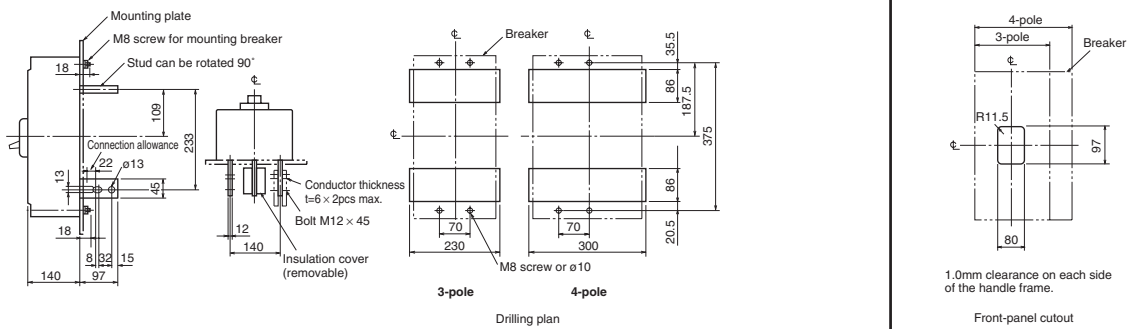

Plug-in

Outside dimensions are different from those of NF1000-SEW and NF1250-SEW.

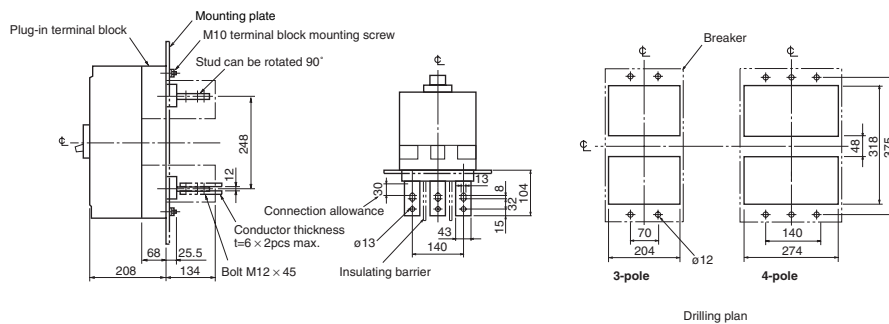

Remark: 1. Standard specifications of NF1250-SDW is 2-pole models. 3-pole and 4-pole models are for DC special voltage.
2. 2-pole models are 3-pole models with the central pole removed.

6. Characteristics and Dimensions

Molded-Case Circuit Breakers

NF1600-SEW



Type NF1600-SEW

Type name		NF1600-SEW		
Rated current In (Amp.)		Adjustable 800-1600		
Number of poles		3	4	
Rated insulation voltage Ui (V)		690		
Rated short-circuit breaking capacity (kA)	IEC 60947-2 (Icu/Ics)	AC	690V	25/13
			500V	65/33
			440V	85/43
			400V	85/43
			230V	125/63
Standard Attached Parts	Front connection	Mounting screw: M8 × 40 (4pcs) Insulating barrier: (3P: 2pcs, 4P: 3pcs) Auxiliary handle: (1pc)		
	Rear connection	Mounting screw: M8 × 40 (4pcs) Auxiliary handle: (1pc)		

Operating Characteristics

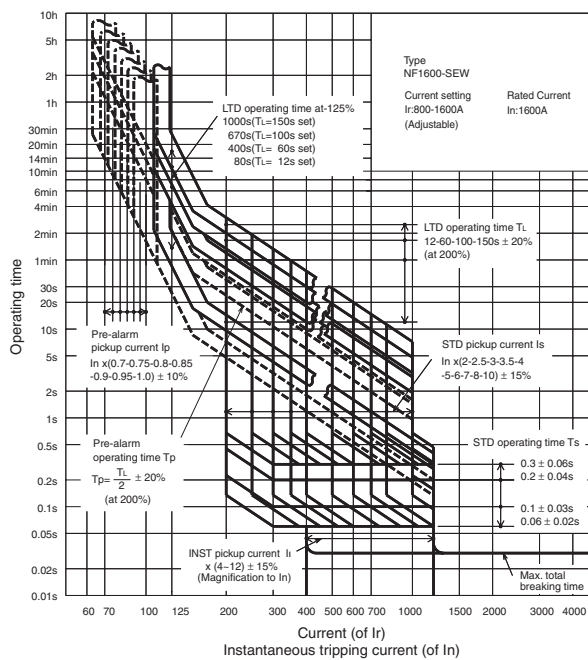

Internal Accessories

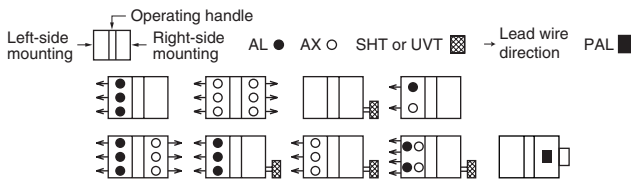

Remark: 1. Refer to page 49.

Current reducing curve

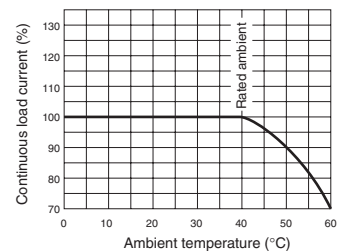

External Accessories

(An order for ☆ should be placed at the same time as an order of circuit breaker main body.)

Accessories	Type name	Reference page	Accessories	Type name	Reference page
Operating handle	F	F10SW (※1)	Auxiliary handle	HT-10SW	80
	S	S10SW		68	
Mechanical interlock (MI)	MI-16SW3 (※1)	79	Electrical operation device	☆	71

Note (※1) The designation depends on the number of poles. Refer to the reference page.

Front connection

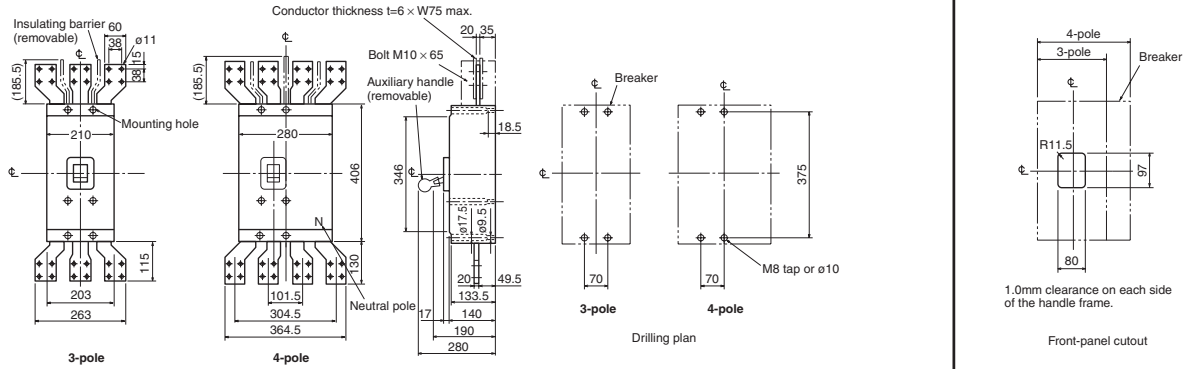

Rear connection

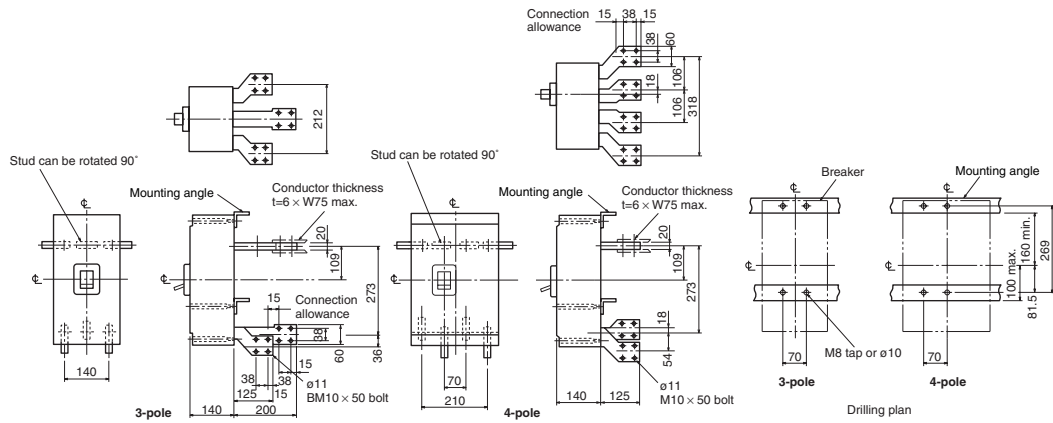

6. Characteristics and Dimensions

Molded-Case Circuit Breakers

NF1600-SDW



Type NF1600-SDW

Type name		NF1600-SDW	
Rated current In (Amp.)		1600	
Number of poles		2	
Rated insulation voltage Ui (V)		690	
Rated short-circuit breaking capacity (kA) IEC 60947-2 (Icu/Ics) Time constant not larger than 10msec	DC	250V	40/20
Standard Attached Parts	Front connection	Mounting screw: M8 × 40 (4pcs) Insulating barrier: (2P: 1pc, 3P: 2pcs, 4P: 3pcs) Auxiliary handle: (1pc)	
	Rear connection	Mounting screw: M8 × 40 (4pcs) Auxiliary handle: (1pc)	

Operating Characteristics

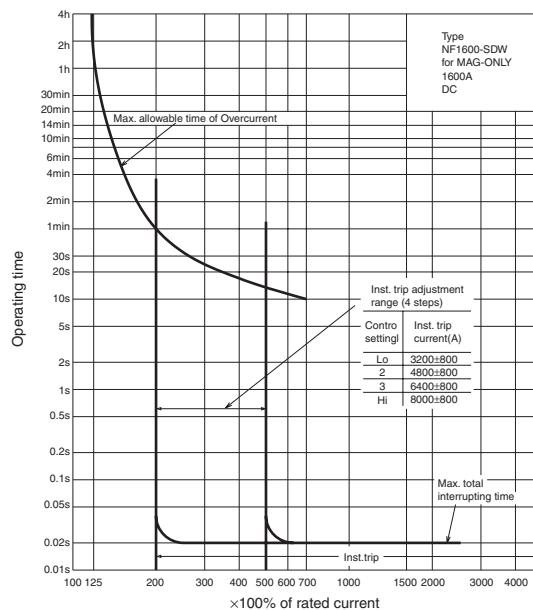

Internal Accessories

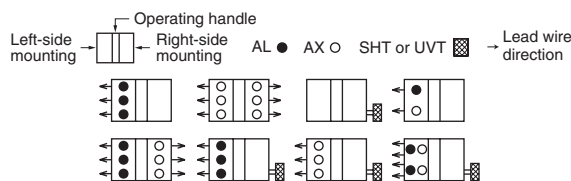

Remark: 1. Refer to page 49.

External Accessories

(An order for ☆ should be placed at the same time as an order of circuit breaker main body.)

Accessories	Type name	Reference page	Accessories	Type name	Reference page
Operating handle	F	F10SW (*1)	Auxiliary handle	HT-10SW	80
	S	S10SW		68	
Mechanical interlock (MI)	MI-16SW3 (*1)	79	Electrical operation device	☆	71

Note (*1) The designation depends on the number of poles. Refer to the reference page.

Front connection

Outside dimensions are same as those of NF1600-SEW.

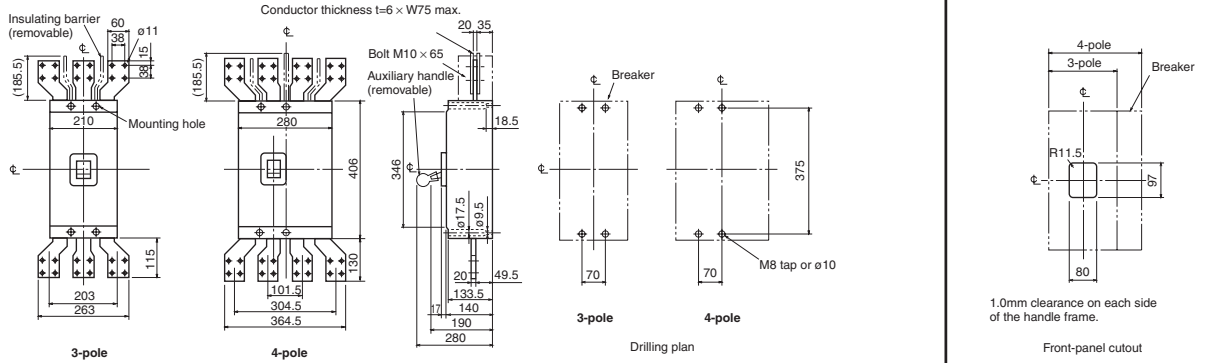

Rear connection

Outside dimensions are different from those of NF1600-SEW.

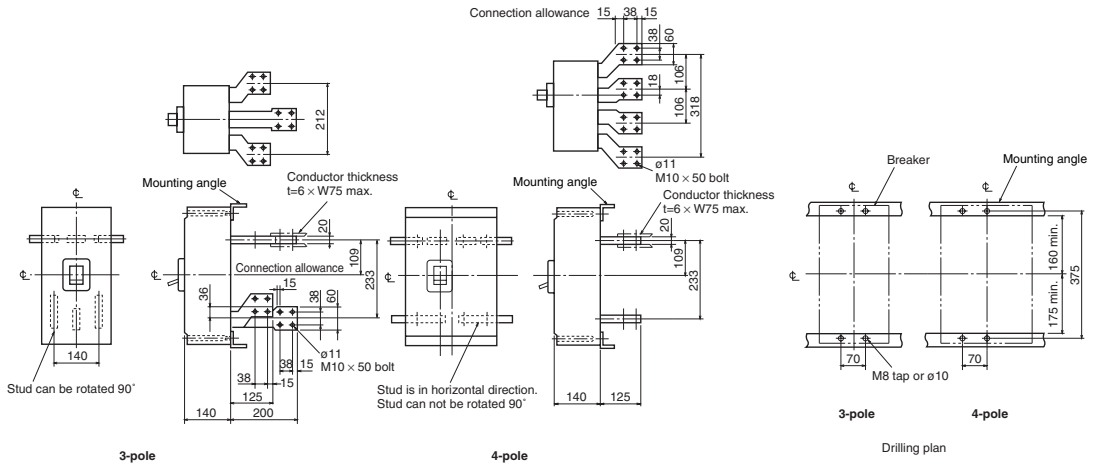

- Remark: 1. Standard specification of NF1600-SDW is 2-pole model. 3-pole and 4-pole models are for DC special voltage.
 2. 2-pole models are 3-pole models with the central pole removed.

6. Characteristics and Dimensions

Earth-Leakage Circuit Breakers

NV30-CS



Type NV30-CS

Type name		NV30-CS	
Number of poles		3	
Rated operational voltage Ue (V AC)		100-230 Multi-voltage type	
Rated current In (A)		5 10 15 20 30	
High-speed type	Rated current sensitivity I Δ n (mA)	30	
	Max. operating time at 5I Δ n (s)	0.04	
Time-delay type	Rated current sensitivity I Δ n (mA)	—	
	Max. operating time at 2I Δ n (s)	—	
	Inertial non-operating time at 2I Δ n (s)	—	
Earth-leakage indication system		Button	
Rated short-circuit breaking capacity (kA) IEC 60947-2 2nd. ed lcu/lcs	AC	440V	—
		400V	—
		230V	2.5/2
Standard Attached Parts (Front connection)		Mounting screw: M4 × 0.7 × 20 (2pcs.)	

Operating Characteristics

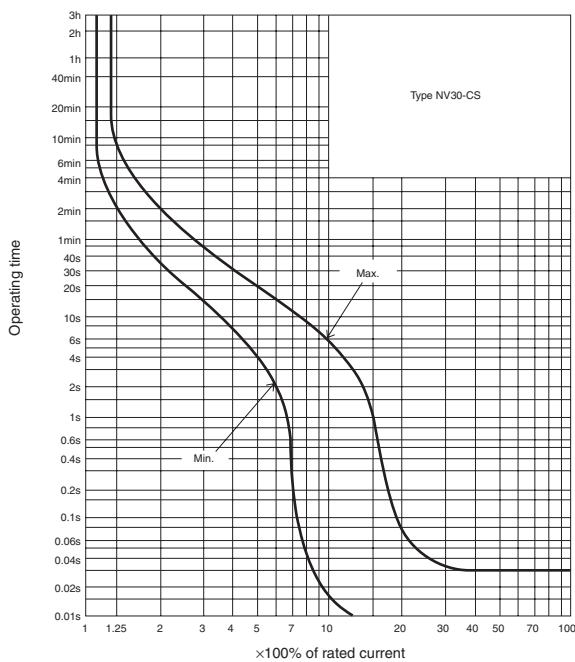

Earth-Leakage Tripping Characteristics

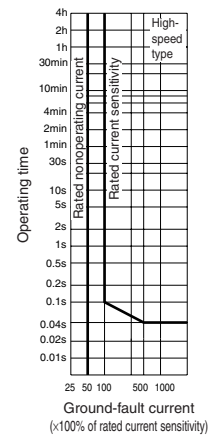

Internal Accessories

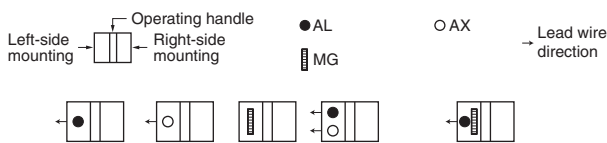

Remark: 1. Standard lead wire is drawn from side. However, lead wire drawn by load can be produced upon request.
2. Refer to page 48.

Temperature Characteristics

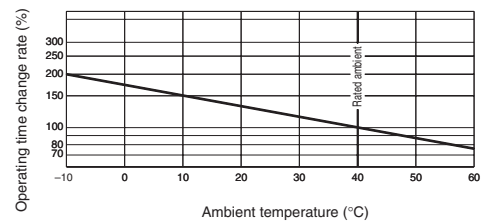

External Accessories

Accessories	Type name	Reference page	Accessories	Type name	Reference page
Lock cover (LC)	LC03CS	80	Small (TC-S)	TCS-03CS3W	70
Rail mounting adapter	DIN-03CS	80	Large (TC-L)	TCL-03CS3W	
Handle lock device	HL-05FH	80	Rear (BTC)	BTC-03CS	
			Skeleton (TTC)	TTC-03CS	

Internal Wiring Diagram

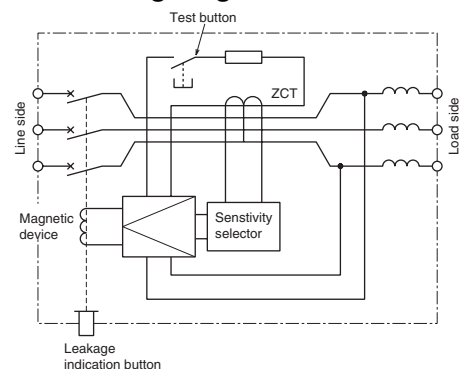

Front connection

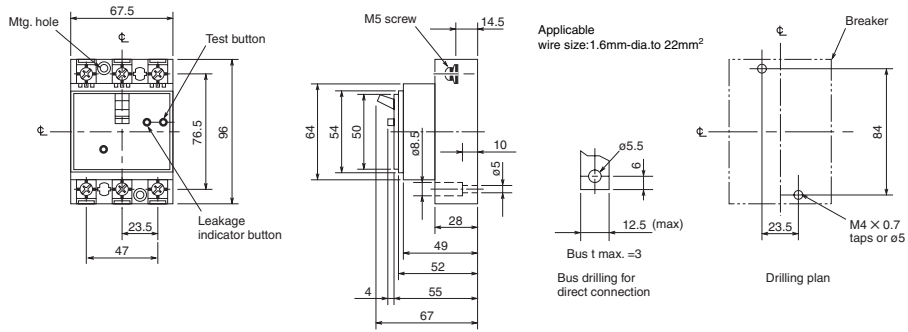

Rear connection

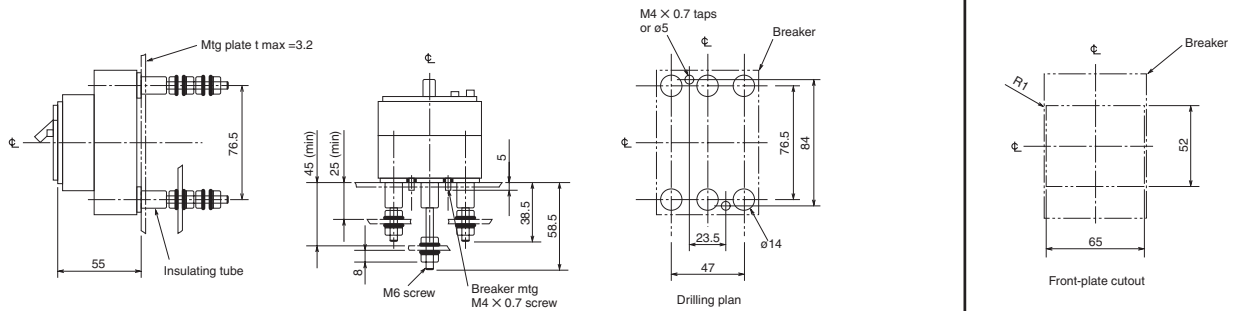

6. Characteristics and Dimensions

Earth-Leakage Circuit Breakers

NV32-SW **NV63-CW**
NV63-SW **NV63-HW**



Type NV63-SW

Type name	NV32-SW	NV63-CW	NV63-SW	NV63-HW
Rated current I _n (Amp.)	(5) 6 10 (15) 16 20 25 (30) 32	(5) (10) (15) 16 20 25 (30) 32 40 50 (60) 63	(5) (10) (15) 16 20 25 (30) 32 40 50 (60) 63	(15) 16 20 25 (30) 32 40 50 (60) 63
Number of poles	3	3	3	3
Rated operational voltage U _e (V AC)	100-440 Multi-voltage type	100-440 Multi-voltage type	100-440 Multi-voltage type	100-440 Multi-voltage type
High-speed type	Rated current sensitivity I _{Δn} (mA)	30,100•200•500 Selectable	30,100•200•500 Selectable	30,100•200•500 Selectable
	Max. operating time at 5I _{Δn} (s)	0.04	0.04	0.04
Earth-leakage indication system		Button	Button	Button
Rated short-circuit breaking capacity (kA) IEC 60947-2 2nd. ed. (Icu/Ics)	AC440V	5/2	2.5/1	7.5/4
	AC400V	5/2	5/2	7.5/4
	AC230V	10/5	7.5/4	15/8
Standard Attached Parts (Front connection)		Mounting screw: M4×0.7×55 (2pcs) Insulation barrier: (3P: 2pcs) excluding models of NV63-CW		

Operating Characteristics

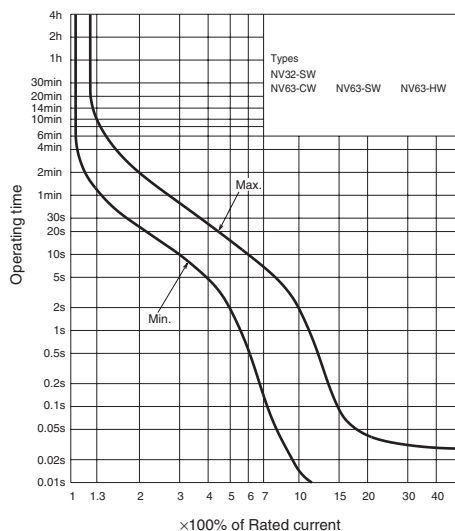

Earth-Leakage Tripping Characteristics

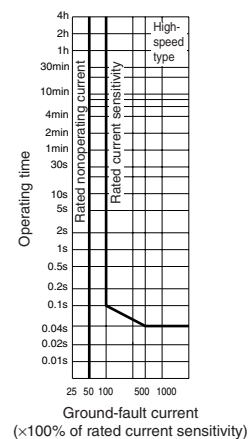

Internal Accessories

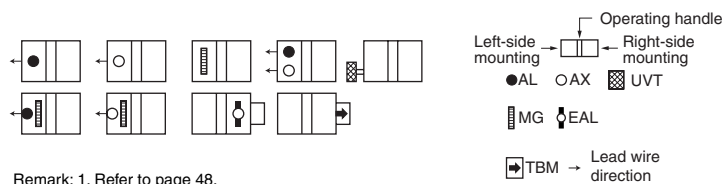

Temperature Characteristics

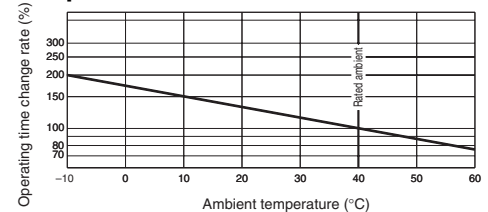

External Accessories

Accessories	Type name	Reference page	Accessories	Type name	Reference page	
Operating handle	F F-05S	61	Mechanical interlock	MI MI-05SW3 (*1)	79	
	V V-05S	64		Terminal cover	Small TC-S	70
	S S05SW	68	Large TC-L		TCL-05SW3W	
Handle lock device	(*1) HLF-05SW	80	Skeleton TTC		TTC-05SW3	
	HL HLN-05SW		Rear BTC		BTC-05SW3W	
	HL-S HLS-05SW		Plug-in PTC		PTC-05SW3W	
	IEC 35mm rail mounting adapters		DIN-05SW	80		

Internal Wiring Diagram

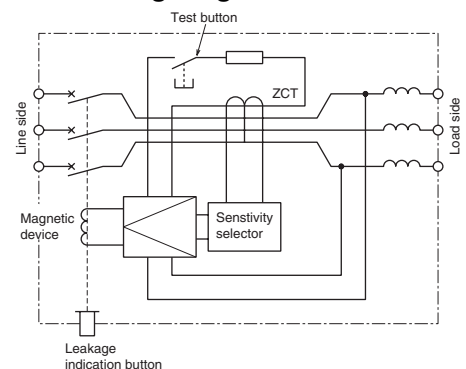

Note (*1) HLF and HLS types are used for OFF-lock, and HLN types for ON-lock.

Front connection

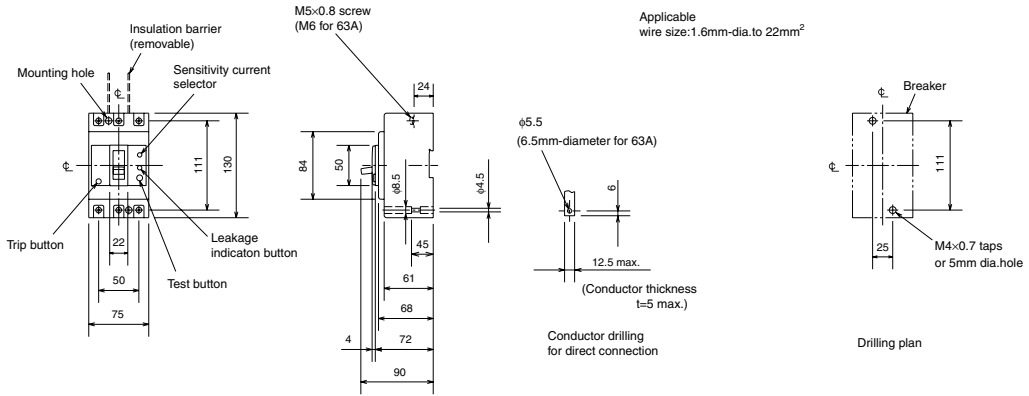

Rear connection

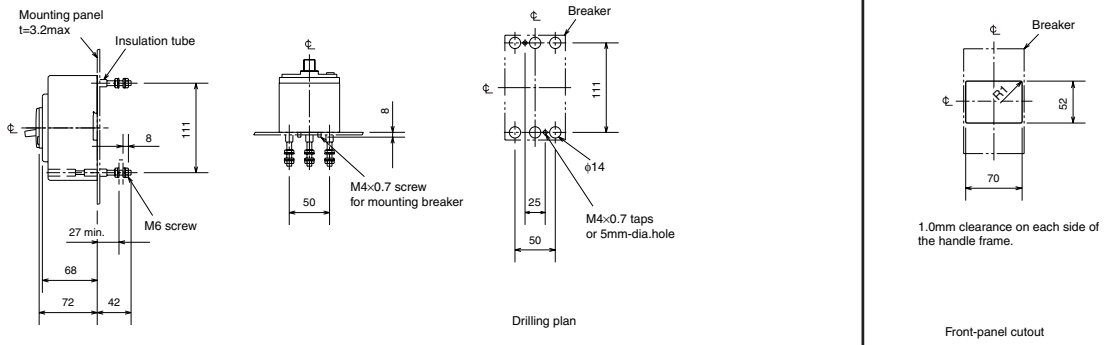

Plug-in

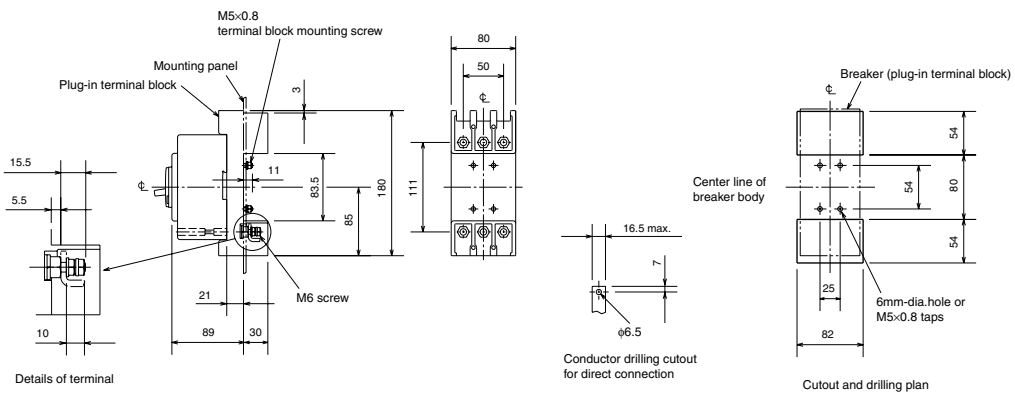

6. Characteristics and Dimensions

Earth-Leakage Circuit Breakers

NV125-CW NV125-SW
NV125-HW



Type NV125-SW

Type name	NV125-CW	NV125-SW	NV125-HW
Rated current I _n (Amp.) (*1)	63 (75) 80 100 125	(15) 16 20 (30) 32 40 50 (60) 63 (75) 80 100 (125 *2)	(15) 16 20 (30) 32 40 50 (60) 63 (75) 80 100
Number of poles	3	3 4	3 4
Rated operational voltage U _e (V AC) (*3)	100-440 Multi-voltage type	100-440 Multi-voltage type	100-440 Multi-voltage type
High-speed type	Rated current sensitivity I _{Δn} (mA)	30,100•200•500 Selectable	30,100•200•500 Selectable
	Max. operating time at 5I _{Δn} (s)	0.04	0.04
Time-delay type	Rated current sensitivity I _{Δn} (mA)	(100•200•500) Selectable	(100•200•500) Selectable
	Max. operating time at 5I _{Δn} (s)	(0.45•1.0•2.0) Selectable	(0.45•1.0•2.0) Selectable
	Inertial non-operating time at 2I _{Δn} (s)	(0.1•0.5•1.0)	(0.1•0.5•1.0)
Earth-leakage indication system	Button	Button	Button
Rated short-circuit breaking capacity (kA) IEC 60947-2 2nd. ed. (Icu/Ics)	AC440V	10/5	25/13
	AC400V	10/5	30/15
	AC230V	30/15	50/25
Standard Attached Parts (Front connection)	Mounting screw: M4x0.7x55 (3P: 2pcs, 4P: 4pcs) Insulation barrier: (3P: 2pcs, 4P: 3pcs) excluding models of NV125-CW		

Note (*1) The time-delayed types will be produced when they have the current specifications of 20A or more.
(*2) 3P only
(*3) Rated operational voltage of time-delay type is for 200-440V.

Operating Characteristics

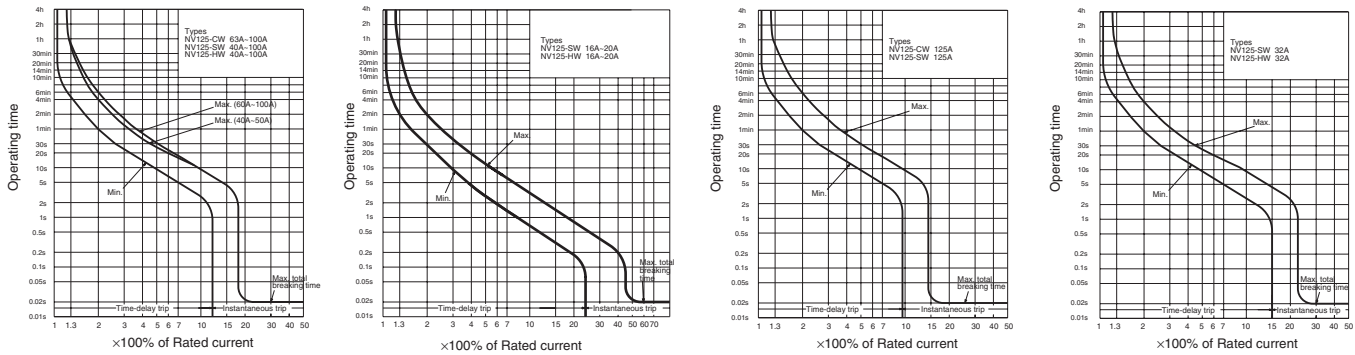

Earth-Leakage Tripping Characteristics

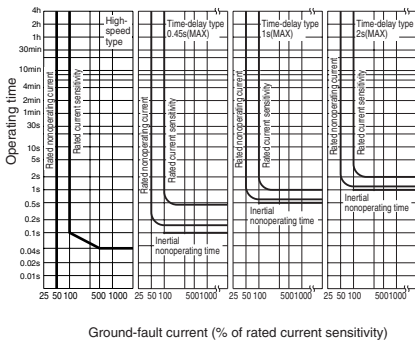

Internal Accessories

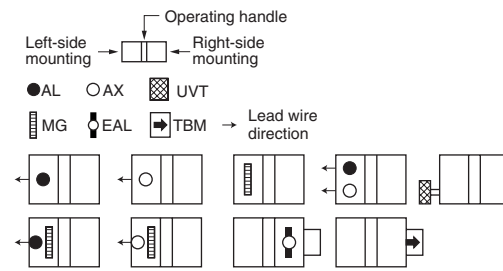

Remark: 1. Refer to page 48.

Temperature Characteristics

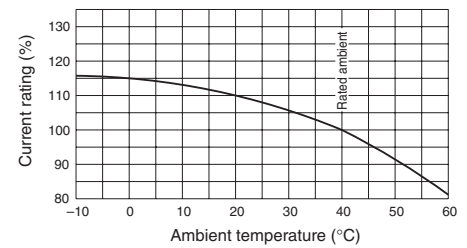

External Accessories

Accessories	Type name	Reference page	Accessories	Type name	Reference page	
Operating handle	F F-1S	61	Mechanical interlock	MI MI-05SW3 (*3)	79	
	V V-1S	64		Terminal cover	Small TC-S TCS-1SW3W (*3)	70
	S S1SW	68			Large TC-L TCL-1SW3W (*3)	
Handle lock device	LC LC-1SW	80	Skeleton TTC TTC-1SW3 (*3)			
	(*1) HLF-1SW		Rear BTC BTC-1SW3W (*3)			
	HL HLN-1SW		Plug-in PTC PTC-1SW3W (*3)			
	HL-S HLS-1SW		IEC 35mm rail mounting adapters	DIN-1SW (*3)	80	
			Electrical operation device	MDS-NV1SWE (*2)	71	

Internal Wiring Diagram

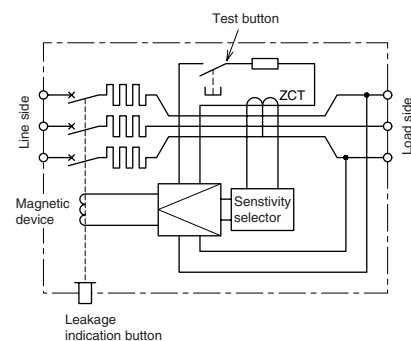

Note (*1) HLF and HLS types are used for OFF-lock, and HLN types for ON-lock.
(*2) Specify the working voltage.
(*3) The designation depends on the number of poles. Refer to the reference page.

Front connection

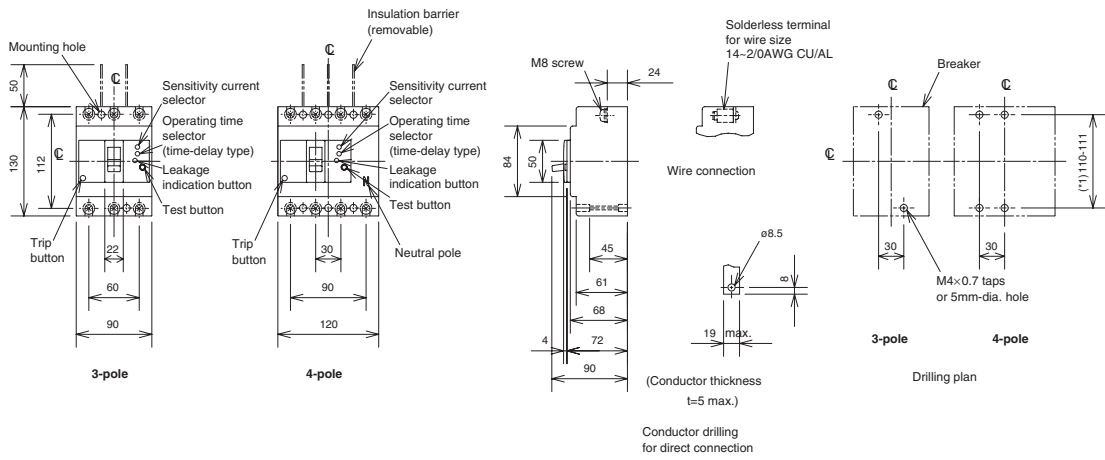

Rear connection

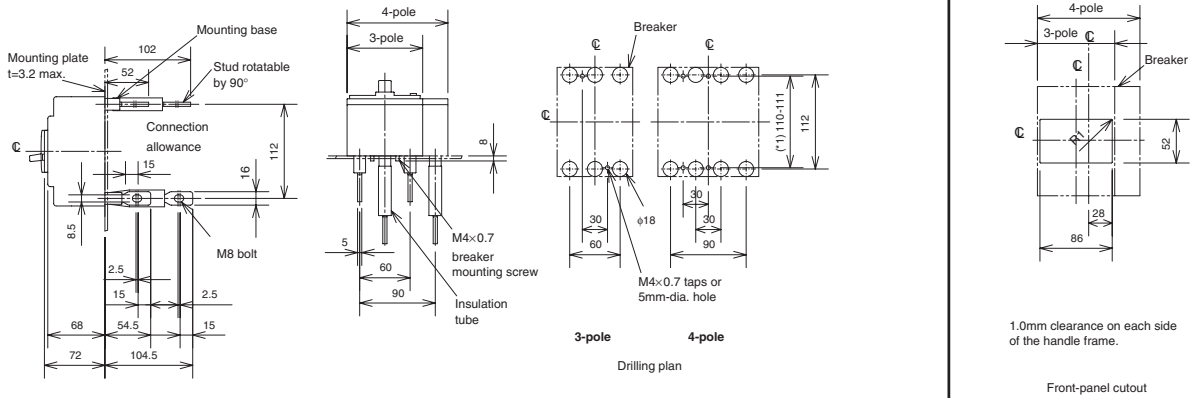

Plug-in

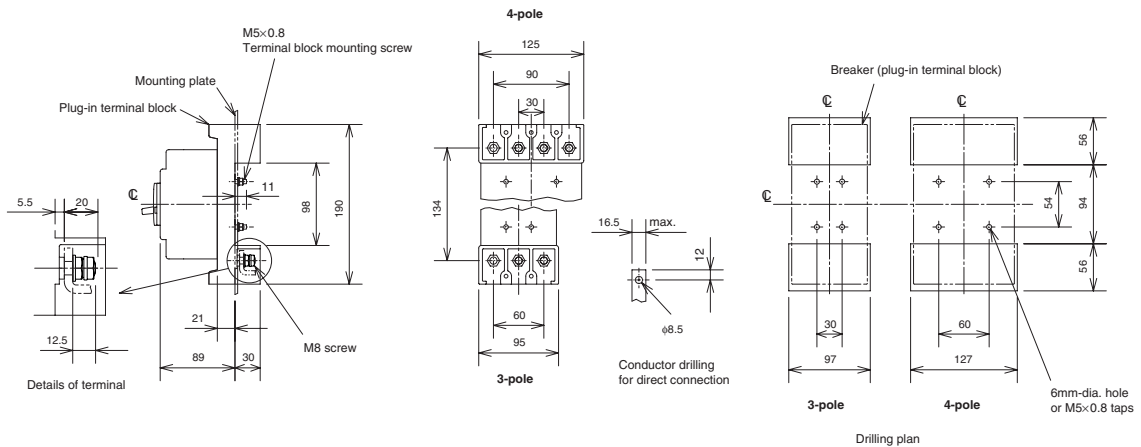

Note (*1) It can respond to the attachment size of 110 and 111 both sides.
Remark: 1. NV125-CW is available in 3-pole only.

6. Characteristics and Dimensions

Earth-Leakage Circuit Breakers

NV250-CW NV250-SW
NV250-HW



Type NV250-SW

Type name		NV250-CW	NV250-SW	NV250-HW
Rated current In (Amp.)		125 150 175 200 225 250	125 150 175 200 225 250	125 150 175 200 225
Number of poles		3	3 4	3 4
Rated operational voltage Ue (V AC) (*1)		100-440 Multi-voltage type	100-440 200-440 Multi-voltage type Multi-voltage type	100-440 200-440 Multi-voltage type Multi-voltage type
High-speed type	Rated current sensitivity IΔn (mA)	30, 100•200•500 Selectable	30, 100•200•500 Selectable	30, 100•200•500 Selectable
	Max. operating time at 5IΔn (s)	0.04	0.04	0.04
Time-delay type	Rated current sensitivity IΔn (mA)	(100•200•500) Selectable	(100•200•500) Selectable	(100•200•500) Selectable
	Max. operating time at 5IΔn (s)	(0.45•1.0•2.0) Selectable	(0.45•1.0•2.0) Selectable	(0.45•1.0•2.0) Selectable
	Inertial non-operating time at 2IΔn (s)	(0.1•0.5•1.0)	(0.1•0.5•1.0)	(0.1•0.5•1.0)
Earth-leakage indication system		Button	Button	Button
Rated short-circuit breaking capacity (kA) IEC 60947-2 2nd. ed. (Icu/Ics)	AC440V	15/8	25/13	50/13
	AC400V	18/9	30/15	50/13
	AC230V	35/18	50/25	100/25
Standard Attached Parts (Front connection)		Mounting screw: M4×0.7×55 (3P: 2pcs, 4P: 4pcs) Insulation barrier: (3P: 4pcs, 4P: 6pcs)		

Note (*1) Rated operational voltage of time-delay type is for 200-440V.

Operating Characteristics

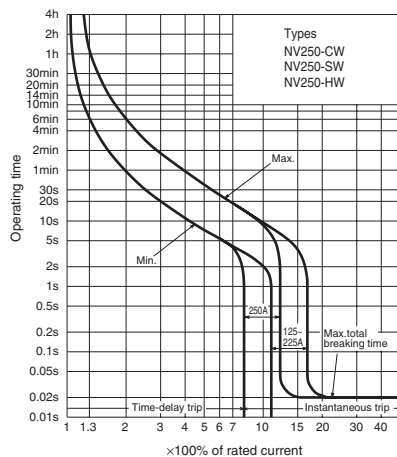

Earth-Leakage Tripping Characteristics

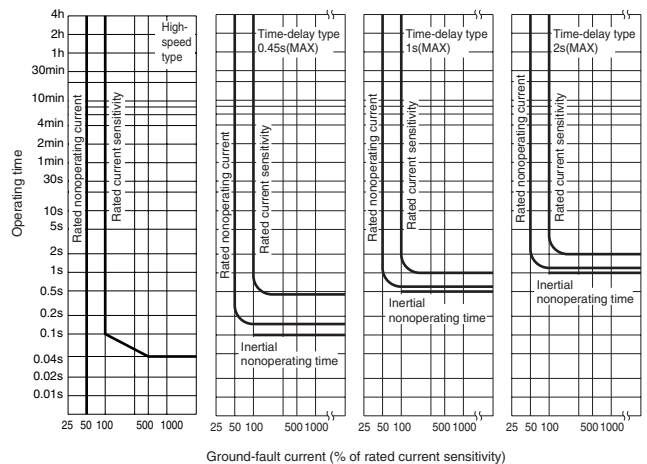

Internal Accessories

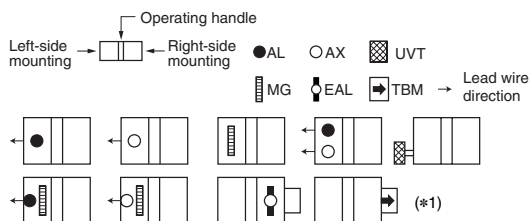

Note (*1) Refer to page 48.

Temperature Characteristics

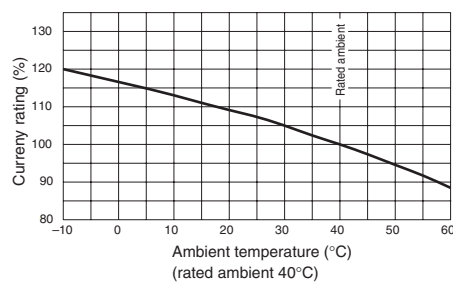

External Accessories

Accessories	Type name	Reference page	Accessories	Type name	Reference page	
Operating handle	F F-2S	61	Mechanical interlock	MI MI-05SW3 (*2)	79	
	V V-2S	64		Terminal cover	Small TC-S	TCS-2SW3W (*2)
	S S2SW	68	Large TC-L		TCL-2SW3W (*2)	
Handle lock device	LC LC-2SW	80	Skeleton TTC		TTC-2SW3 (*2)	70
	(*1) HLF-HLF-2SW		Rear BTC		BTC-2SW3W (*2)	
	HL HLN-2SW		Plug-in PTC	PTC-2SW3W (*2)		
	HL-S HLS-2SW		Electrical operation device	MDS-NV2SWE (*3)	71	

Note (*1) HLF types are used for OFF-lock, and HLN types for ON-lock.
(*2) The designation depends on the number of poles. Refer to the reference page.
(*3) Specify the working voltage.

Internal Wiring Diagram

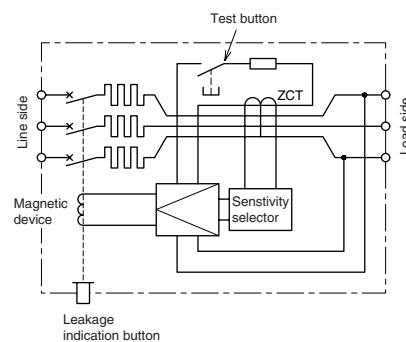

Front connection

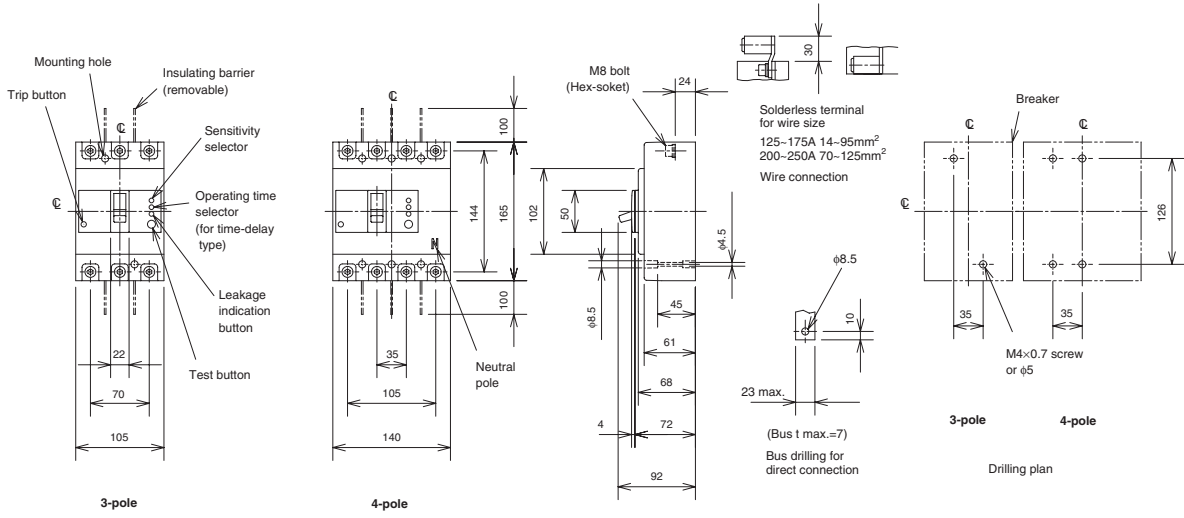

Rear connection

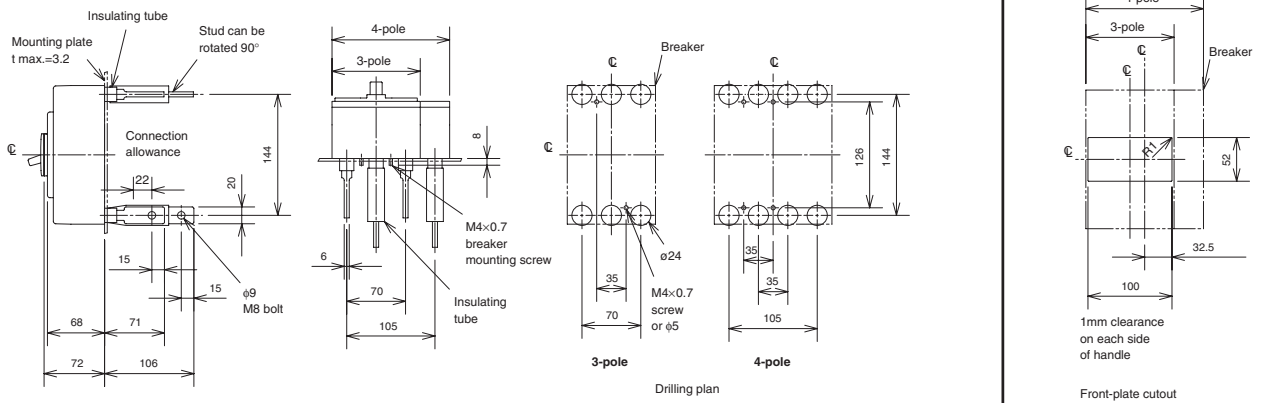

Plug-in

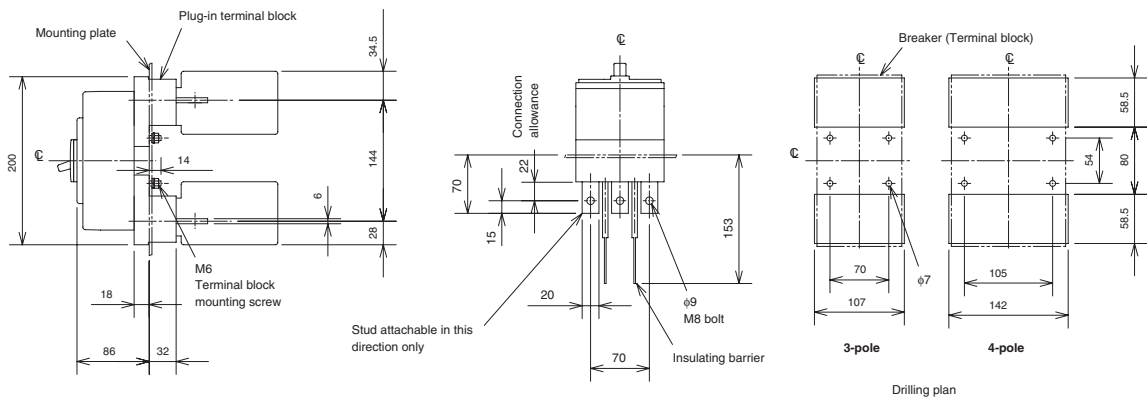

Remark: 1. NV250-CW are available in 3-pole only.

6. Characteristics and Dimensions

Earth-Leakage Circuit Breakers

NV250-SEW NV250-HEW



Type NV250-SEW

Type name		NV250-SEW	NV250-HEW
Rated current In (Amp.)		125-225 Adjustable	125-225 Adjustable
Number of poles		3 4	3 4
Rated operational voltage Ue (V AC) (*1)		100-440 Multi-voltage type	100-440 Multi-voltage type
High-speed type	Rated current sensitivity IΔn (mA)	(30) 100•200•500 Selectable	(30) 100•200•500 Selectable
	Max. operating time at 5IΔn (s)	0.04	0.04
Time-delay type	Rated current sensitivity IΔn (mA)	(100•200•500) Selectable	(100•200•500) Selectable
	Max. operating time at 5IΔn (s)	(0.45•1.0•2.0) Selectable	(0.45•1.0•2.0) Selectable
	Inertial non-operating time at 2IΔn (s)	(0.1•0.5•1.0)	(0.1•0.5•1.0)
Earth-leakage indication system		Button	Button
Rated short-circuit breaking capacity (kA) IEC 60947-2 2nd. ed. (Icu/Ics)	AC440V	25/13	50/13
	AC400V	30/15	50/13
	AC230V	50/25	100/25
Standard Attached Parts (Front connection)		Mounting screw: M4×0.7×55 (3P: 2pcs, 4P: 4pcs) Insulation barrier: (3P: 4pc, 4P: 6pcs)	

Note (*1) Rated operational voltage of time-delay type is for 200-440V.

Operating Characteristics

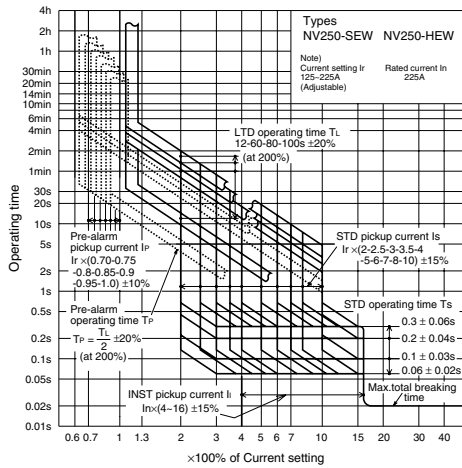

Note) Instantaneous tripping current (×100% of In)

Earth-Leakage Tripping Characteristics

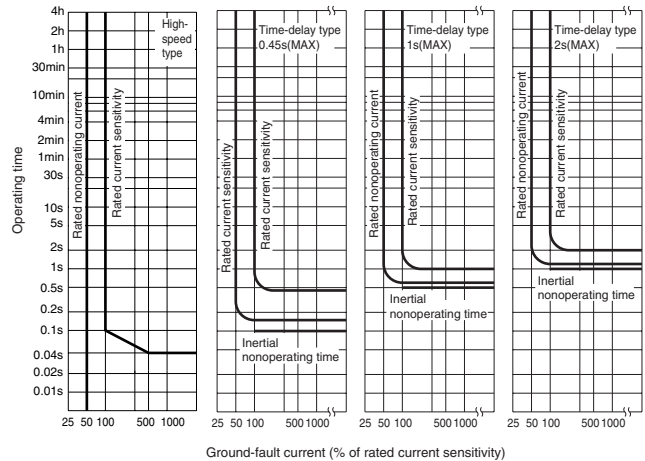

Internal Accessories

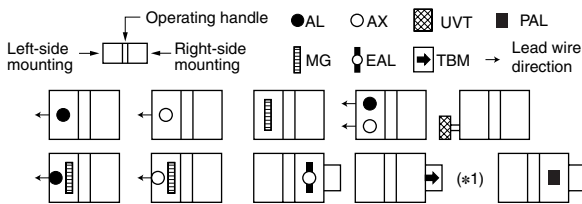

Temperature Characteristics

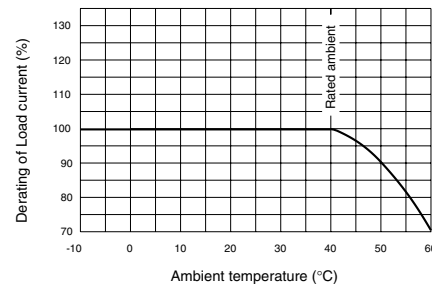

External Accessories

Accessories	Type name	Reference page	Accessories	Type name	Reference page
Operating handle	F F-2S	61	Mechanical interlock	MI MI-05SW3 (*2)	79
	V V-2S	64		Small TC-S TCS-2SW3W (*2)	70
	S S2SW	68		Large TC-L TCL-2SW3W (*2)	
Handle lock device	LC LC-2SW	80	Terminal cover	Skeleton TTC TTC-2SW3 (*2)	
	(*1) HLF-HLF-2SW			Rear BTC BTC-2SW3W (*2)	
	HL HLN-2SW			Plug-in PTC PTC-2SW3W (*2)	
	HLS HLS-2SW			Electrical operation device MDS-NVE2SWE (*3)	

Note (*1) HLF types are used for OFF-lock, and HLN types for ON-lock.
(*2) The designation depends on the number of poles. Refer to the reference page.
(*3) Specify the working voltage.

Internal Wiring Diagram

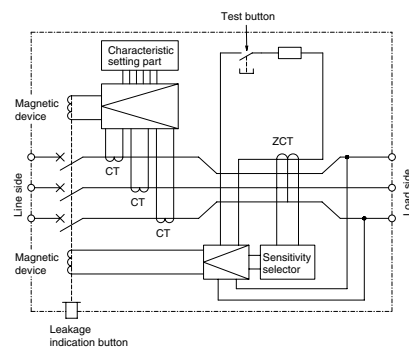

Front connection

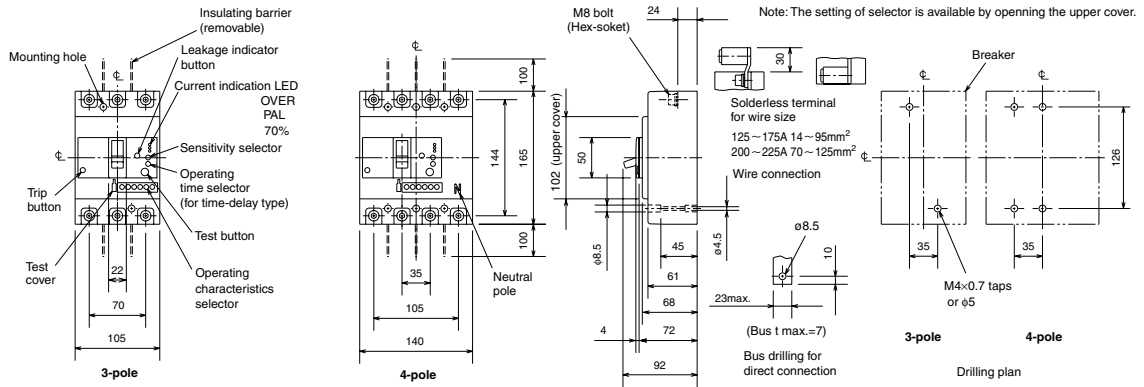

Rear connection

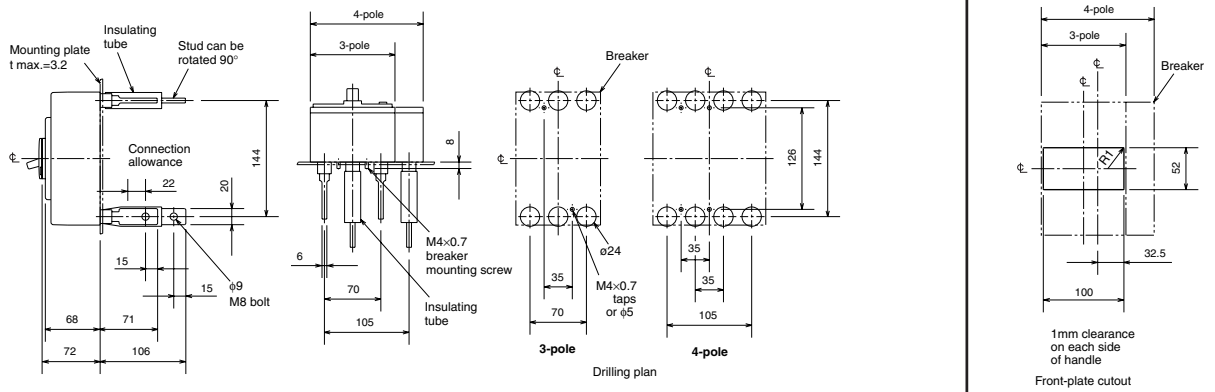

Plug-in

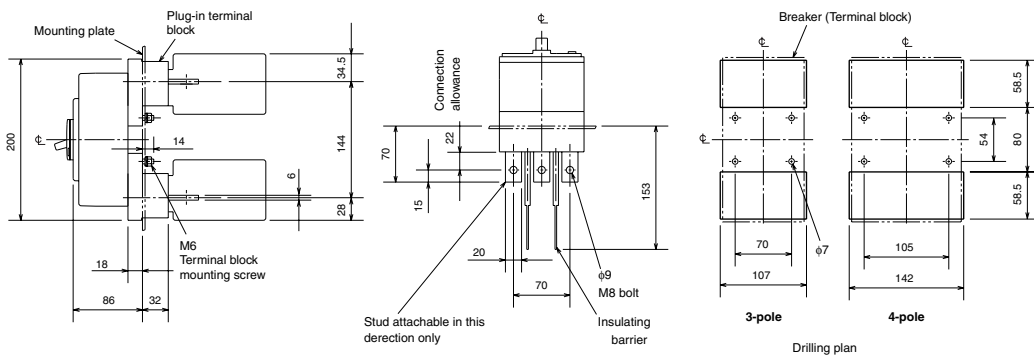

6. Characteristics and Dimensions

Earth-Leakage Circuit Breakers

NV125-RW



Type NV125-RW

Type name		NV125-RW
Rated current I _n (Amp.) (*1)		(15) 16 20 (30) 32 40 50 (60) 63 (75) 80 100
Number of poles		3
Rated operational voltage U _e (V AC) (*2)		100-440 Multi-voltage type
High-speed type	Rated current sensitivity I _{Δn} (mA)	(30) 100•200•500 Selectable
	Max. operating time at 5I _{Δn} (s)	0.04
Time-delay type	Rated current sensitivity I _{Δn} (mA)	(100•200•500) Selectable
	Max. operating time at 5I _{Δn} (s)	(0.45•1.0•2.0) Selectable
	Inertial non-operating time at 2I _{Δn} (s)	(0.1•0.5•1.0)
Earth-leakage indication system		Button
Rated short-circuit breaking capacity (kA) IEC 60947-2 2nd. ed. (Icu/Ics)	AC440V	125/125
	AC400V	125/125
	AC230V	125/125
Standard Attached Parts (Front connection)		Mounting screw : M4×0.7×73 (4pcs) Insulation barrier : (3P:4pcs, 4P:6pcs)

Note (*1) The Time-delayed types will be produced when they have the current specifications of 20A or more.
(*2) Rated operational voltage of time-delay type is for 200-440V.

Operating Characteristics

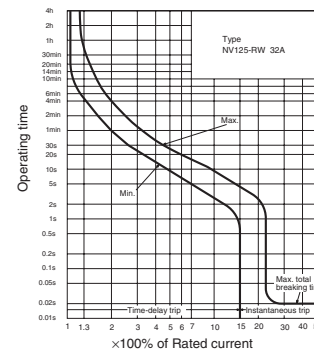
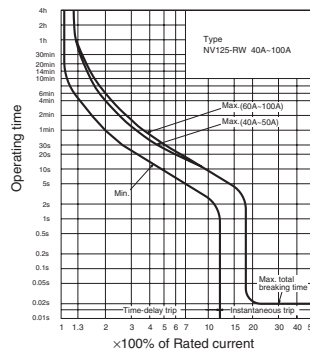
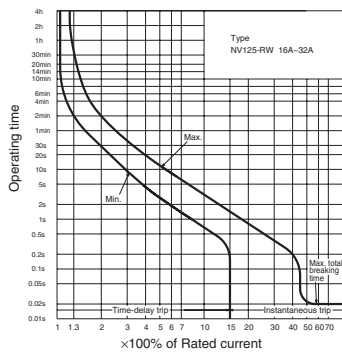

Earth-Leakage Tripping Characteristics

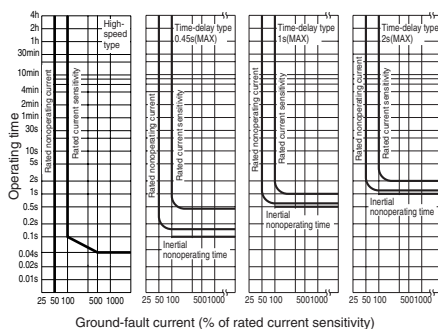

Internal Accessories

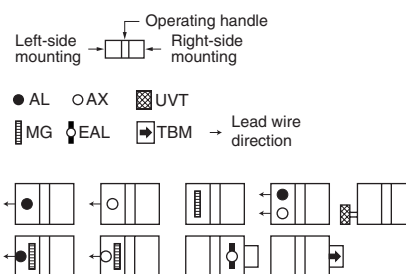

Remark: 1. Refer to page 48.

Temperature Characteristics

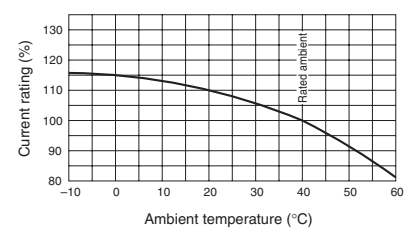

External Accessories

Accessories	Type name	Reference page	Accessories	Type name	Reference page
Operating handle	F F-1U	61	Terminal cover	Small TC-S	TCS-1SW3W (*1)
	V V-1U	64		Large TC-L	TCL-1SW3W (*1)
	S S1SW	68		Skeleton TTC	TTC-1SW3 (*1)
Mechanical interlock	MI MI-05SW3 (*1)	79		Rear BTC	BTC-1SW3W (*1)
	Electrical operation device	—		Plug-in PTC	PTC-1SW3W (*1)
Handle lock device	LC LC-1SW	80	LC LC-1SW	LC-1SW	
	HL HLF-1SW		HLF-1SW		
	HL HLN-1SW		HLN-1SW		
HL-S	HLS-1SW				

Internal Wiring Diagram

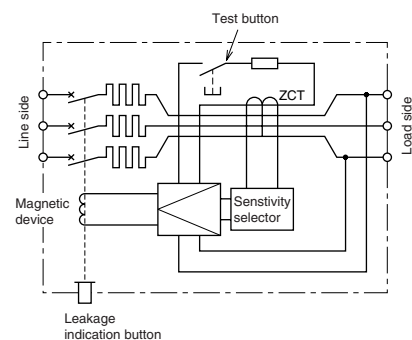

Note (*1) The designation depends on the number of poles. Refer to the reference page.
(*2) HLF and HLS types are used for OFF-lock, and HLN types for ON-lock.

Front connection

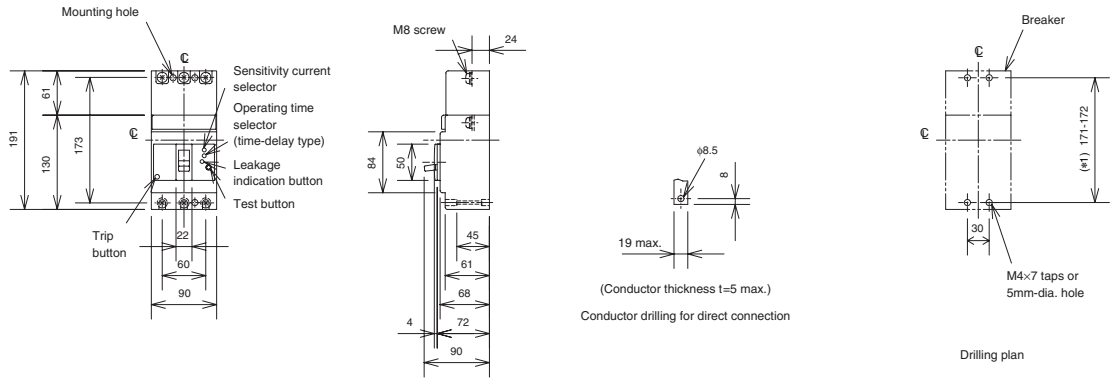

Rear connection

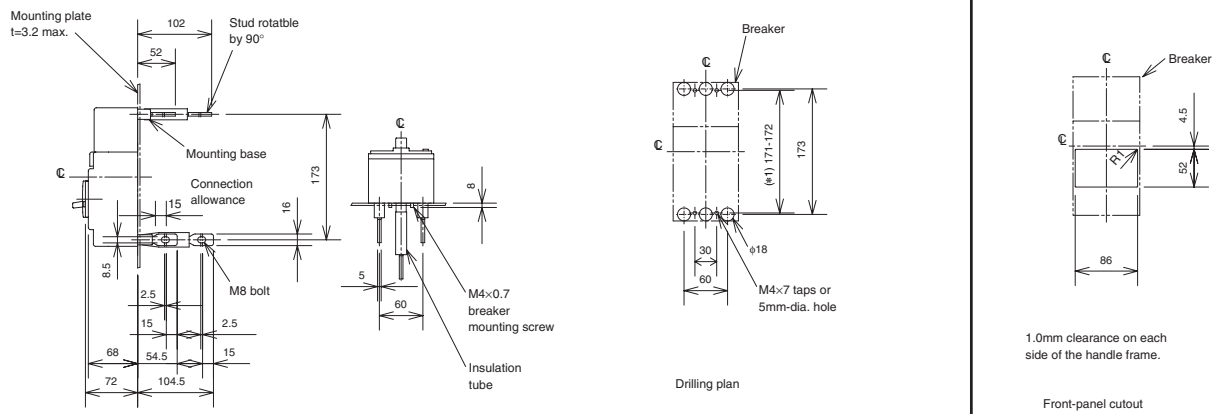

Plug-in

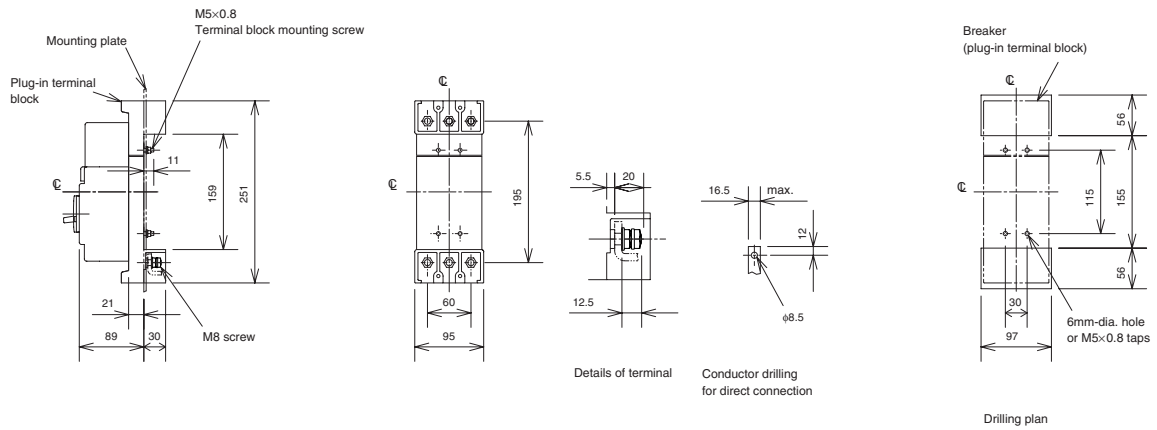

Note (*1) It can respond to the attachment size of 171 and 172 both sides.

6. Characteristics and Dimensions

Earth-Leakage Circuit Breakers

NV250-RW



Type NV250-RW

Type name		NV250-RW
Rated current In (Amp.)		125 150 175 200 225
Number of poles		3
Rated operational voltage Ue (V AC) (*1)		100-440 Multi-voltage type
High-speed type	Rated current sensitivity IΔn (mA)	(30) 100•200•500 Selectable
	Max. operating time at 5IΔn (s)	0.04
Time-delay type	Rated current sensitivity IΔn (mA)	(100•200•500) Selectable
	Max. operating time at 5IΔn (s)	(0.45•1.0•2.0) Selectable
	Inertial non-operating time at 2IΔn (s)	(0.1•0.5•1.0)
Earth-leakage indication system		Button
Rated short-circuit breaking capacity (kA) IEC 60947-2 2nd. ed. (Icu/Ics)	AC440V	125/125
	AC400V	125/125
	AC230V	125/125
Standard Attached Parts (Front connection)		Mounting screw : M4 × 0.7 × 55 (2pcs), M4 × 0.7 × 73 (2pcs) Insulation barrier : (4pcs)

Note (*1) Rated operational voltage of time-delay type is for 200-440V

Operating Characteristics

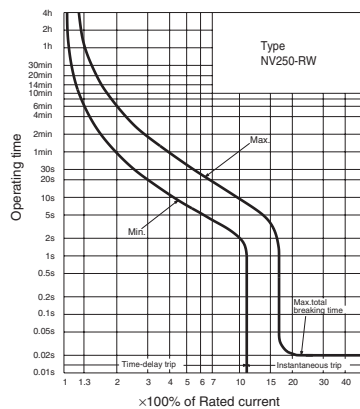

Earth-Leakage Tripping Characteristics

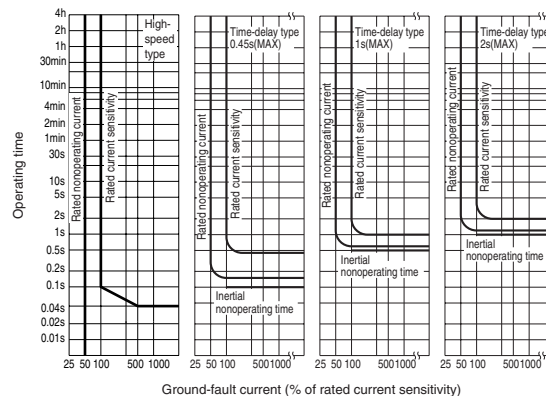

Internal Accessories

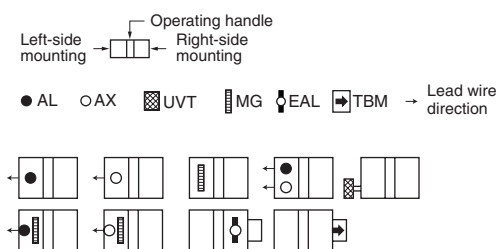

Remark 1. Refer to page 48.

Ambient Compensating Curve

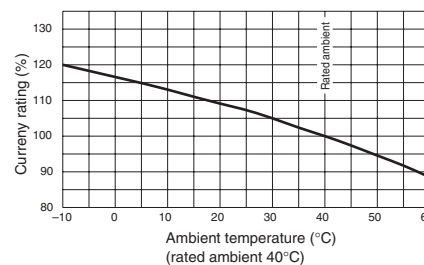

External Accessories

Accessories	Type name	Reference page	Accessories	Type name	Reference page
Operating handle	F F-2U	61	Mechanical interlock	MI MI-05SW3 (*1)	79
	V V-2U	64		Terminal cover	Small TC-S TCS-2SW3W (*1)
	S S2SW	68	Large TC-L TCL-2SW3W (*1)		
Handle lock device	LC LC-2SW	80	Skeleton TTC TTC-2SW3 (*1)		
	(*2) HLF-2SW		Rear BTC BTC-2SW3W (*1)		
	HLN-2SW		Plug-in PTC PTC-2SW3W (*1)		
	HL-S HLS-2SW		Electrical operation device	—	—

Internal Wiring Diagram

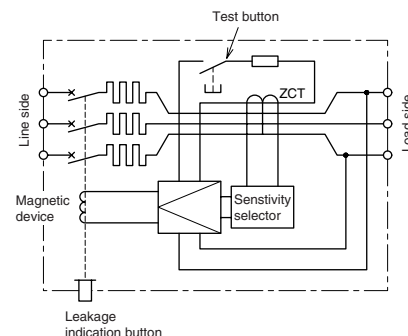

Note (*1) The designation depends on the number of poles. Refer to the reference page.
(*2) HLF types are used for OFF-lock, and HLN types for ON-lock.

Front connection

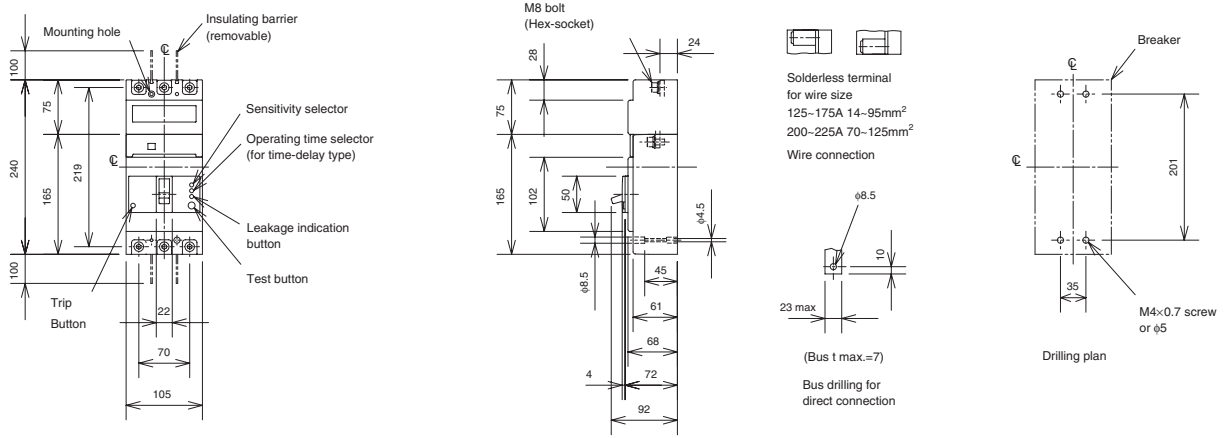

Rear connection

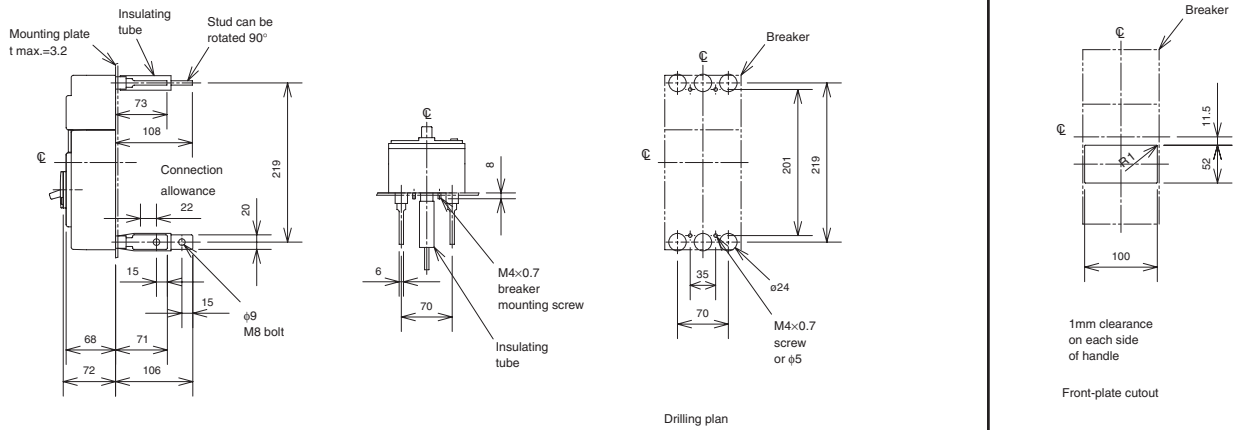

Plug-in

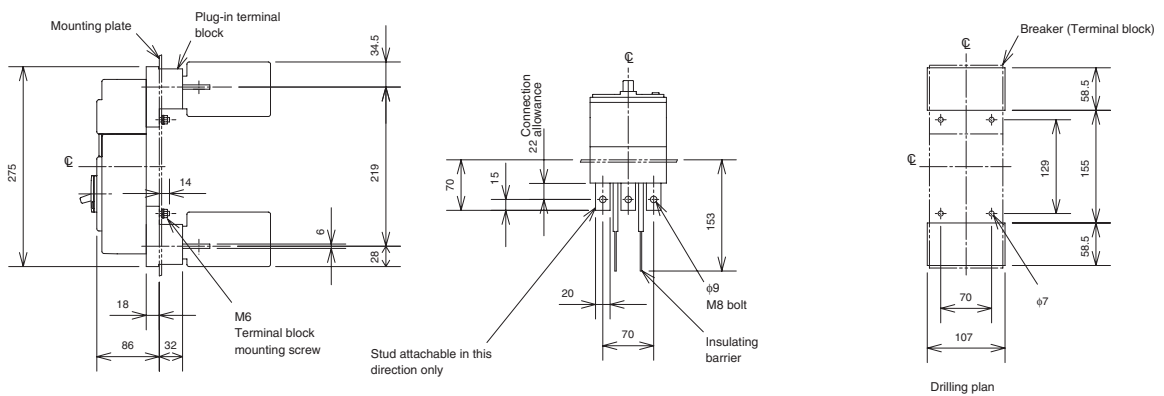

6. Characteristics and Dimensions

Earth-Leakage Circuit Breakers

NV400-CW
NV400-SW



Type NV400-SW

Type name		NV400-CW	NV400-SW
Number of poles		3	
Rated operational voltage Ue (V AC) (#1)		100-440 Multi-voltage type	
Rated current In (Amp.)		250 300 350 400	
High-speed type	Rated current sensitivity IΔn (mA)	(30) 100 · 200 · 500 Selectable	
	Max. operating time at 5IΔn (s)	0.04	
Time-delay type	Rated current sensitivity IΔn (mA)	(100 · 200 · 500 Selectable)	
	Max. operating time at 2IΔn (s)	(0.45 · 1.0 · 2.0 Selectable)	
	Inertial non-operating time at 2IΔn (s)	(0.1 · 0.5 · 1.0)	
Earth-leakage indication system		Button	
Rated short-circuit breaking capacity (kA) IEC 60947-2 2nd. ed. (Icu/lcs)	AC	440V	25/13 42/42
		400V	36/18 45/45
		230V	50/25 85/85
Standard Attached Parts (Front connection)		Mounting screw: M6×60 (4pcs) Insulation barrier: (4pcs)	

Note (#1) Rated operational voltage of time-delay type is for 200-440V.

Operating Characteristics

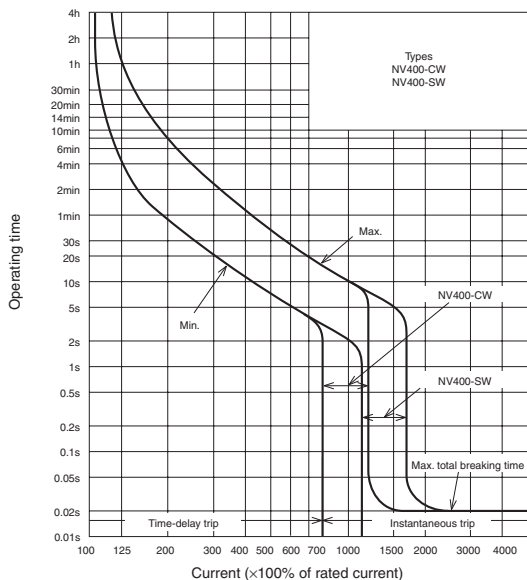

Earth-Leakage Tripping Characteristics

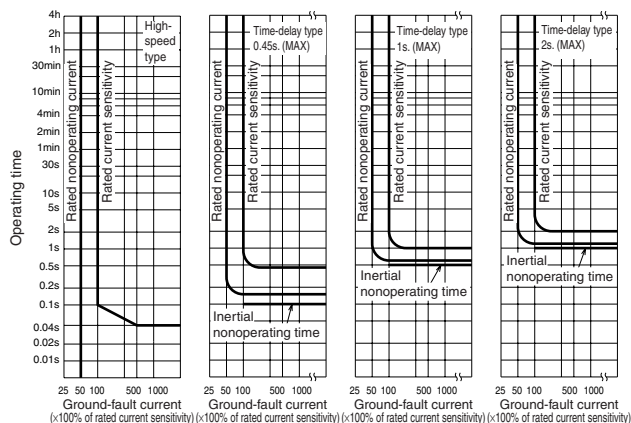

Internal Accessories

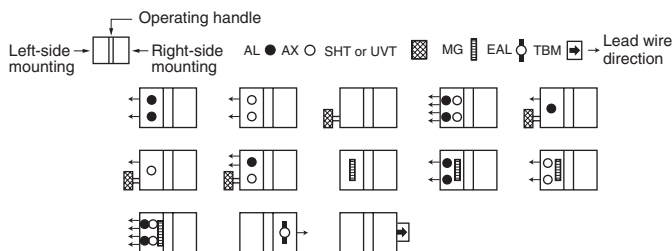

Remark: 1. Refer to page 50 and 51.

External Accessories

(An order for ☆ should be placed at the same time as an order of circuit breaker main body.)

Accessories	Type name	Reference page	Accessories	Type name	Reference page
Operating handle	F F-4S	62	Terminal cover	Large (TC-L) TCL-4SW3	70
	V V-4S	65	Skeleton (TTC) TTC-4SW3		
	S S4CW, S4SW	68	Rear (BTC) BTC-4SW3		
Mechanical interlock (MI)	MI-4SW3 (#1)	79	Handle lock device	HL HL-4CW, HL-4SW	80
Auxiliary handle (HT)	HT-4CW, HT-4SW	80	Electrical operation device	☆	71

Note (#1) The designation depends on the number of poles. Refer to the reference page.

Ambient Compensating Curve

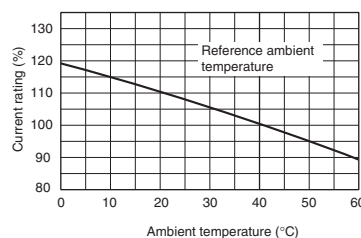

Internal Wiring Diagram

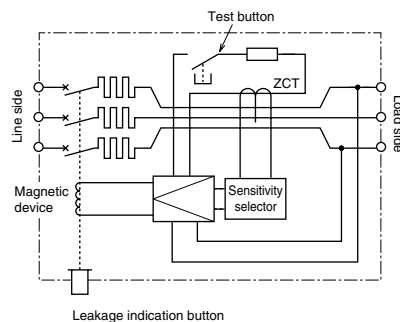

Front connection

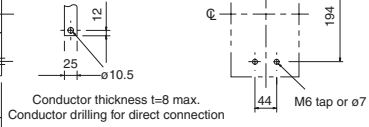
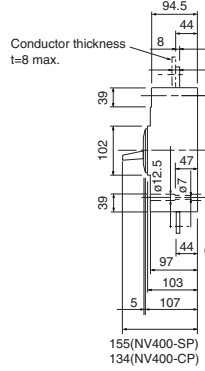
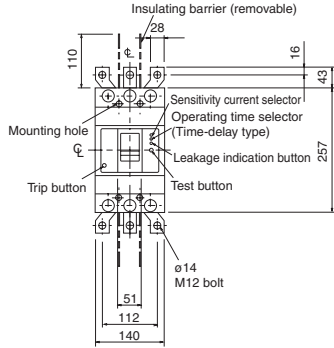

Drilling plan

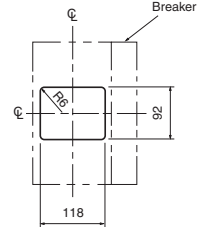

1.0mm clearance on each side of the handle frame.

Front-panel cutout

Rear connection

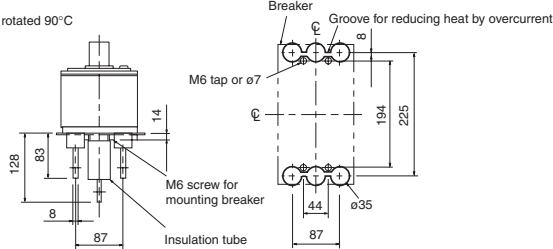
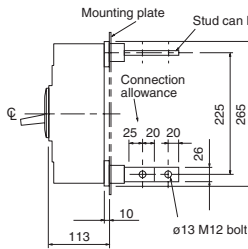

Drilling plan

Boring dimensions for rear connection type barriers (3-pole)

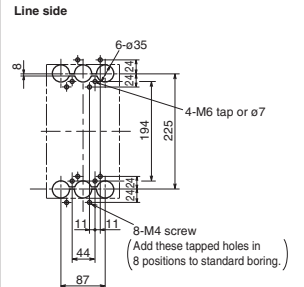

Load side

Note: The bore dimensional drawing shows the breaker viewed from the rear.

Plug-in

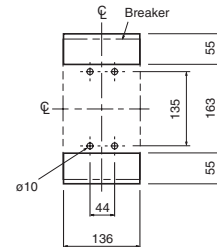
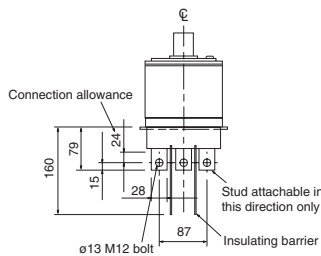
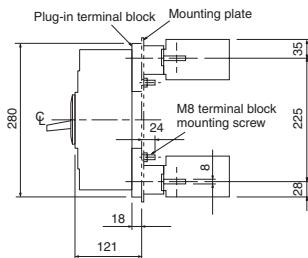

Drilling plan

6. Characteristics and Dimensions

Earth-Leakage Circuit Breakers

NV400-SEW
NV400-HEW
NV400-REW



Type NV400-SEW

Type name		NV400-SEW		NV400-HEW		NV400-REW	
Number of poles		3	4	3	4	3	
Rated operational voltage Ue (V AC) (*1)		100-440 Multi-voltage type					
Rated current In (Amp.)		200-400 adjustable					
High-speed type	Rated current sensitivity IΔn (mA)	(30) 100 · 200 · 500 Selectable					
	Max. operating time at 5IΔn (s)	0.04					
Time-delay type	Rated current sensitivity IΔn (mA)	(100 · 200 · 500 Selectable)					
	Max. operating time at 5IΔn (s)	(0.45 · 1.0 · 2.0 Selectable)					
	Max. inertial non-operating time at 2IΔn (s)	(0.1 · 0.5 · 1.0)					
Earth-leakage indication system		Button					
Rated short-circuit breaking capacity (kA) IEC 60947-2 2nd. ed. (Icu/Ics)	AC	440V	42/42	65/65	125/63		
		400V	50/50	70/70	125/63		
		230V	85/85	100/100	150/75		
Standard Attached Parts (Front connection)		Mounting screw: M6×72 (4pcs) Insulation barrier: (3P: 4pcs, 4P: 6pcs)					

Note (*1) Rated operational voltage of time-delay type is for 200-440V.

Operating Characteristics

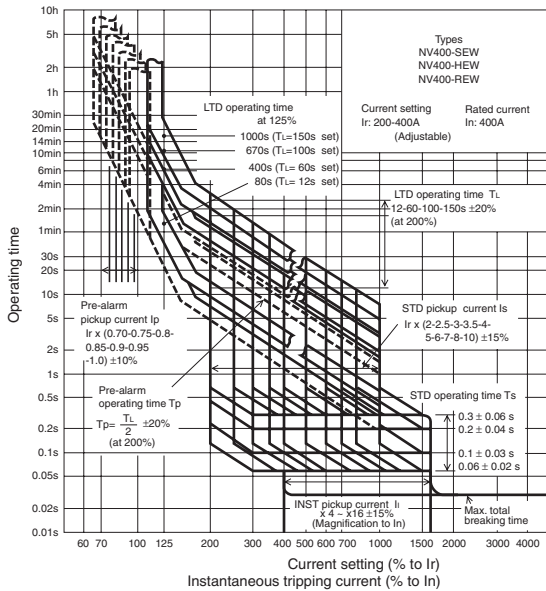

Earth-Leakage Tripping Characteristics

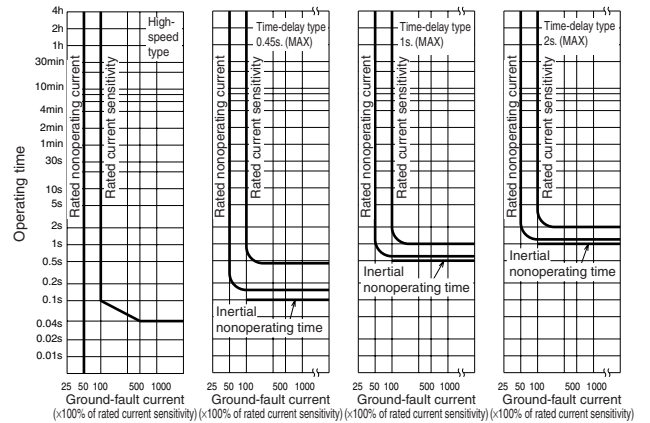

Internal Accessories

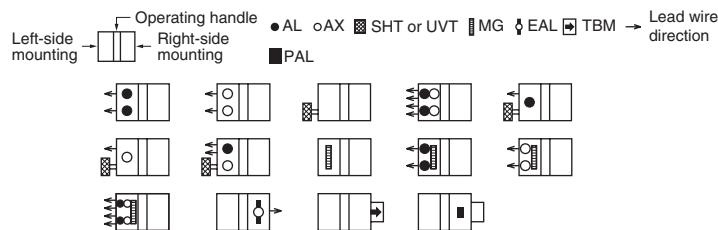

Remark: 1. Instead of EAL and TBM, pre-alarm module (PAL) can be attached.
2. Refer to page 50 and 51.

Current reducing curve

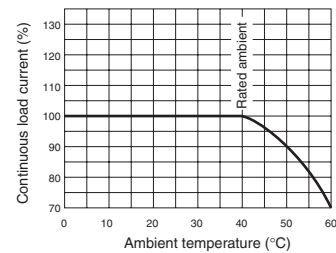

External Accessories

(An order for ☆ should be placed at the same time as an order of circuit breaker main body.)

Accessories	Type name	Reference page	Accessories	Type name	Reference page
Operating handle	F F-4S	62	Terminal cover	Large (TC-L) TCL-4SW3 (*1) (*2)	70
	V V-4S	65		Skeleton (TTC) TTC-4SW3 (*2)	
	S S4SW	68		Rear (BTC) BTC-4SW3 (*1) (*2)	
Mechanical interlock (MI)	MI-4SW3 (*2)	79	Handle lock device	HL HL-4SW	80
Auxiliary handle (HT)	HT-4SW	80	HL-S HLS-4SW		
			Electrical operation device	☆	71

Note (*1) This is for NV400-SEW.
(*2) The designation depends on the number of poles. Refer to the reference page.

Internal Wiring Diagram

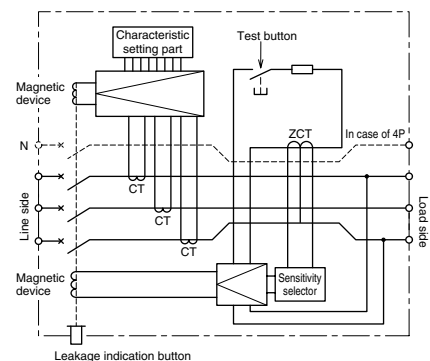

Front connection

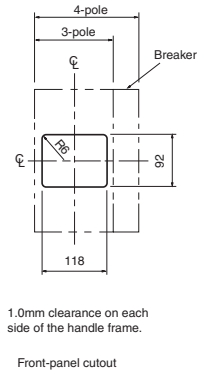
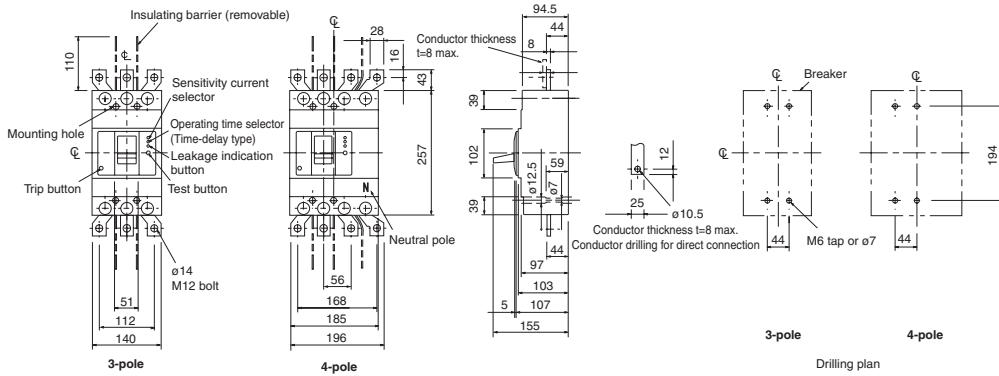

Rear connection

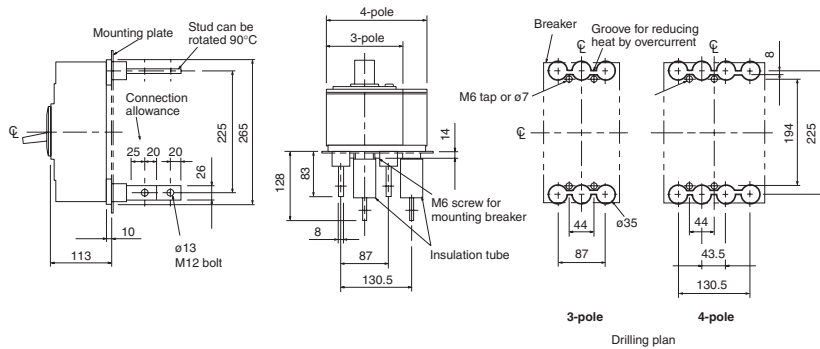

Boring dimensions for rear connection type barriers (3-pole)

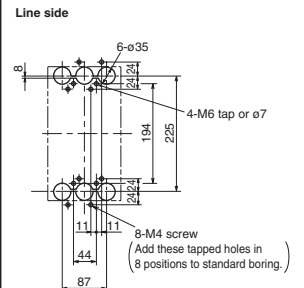

Note: The bore dimensional drawing shows the breaker viewed from the rear.

Plug-in

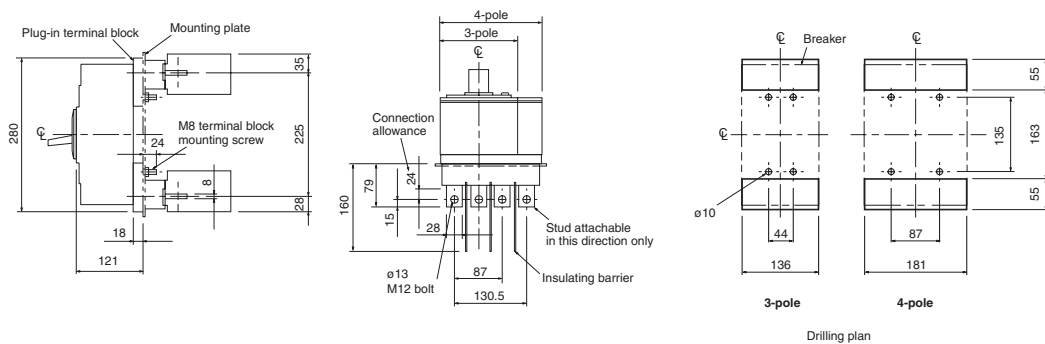

6. Characteristics and Dimensions

Earth-Leakage Circuit Breakers

NV630-CW
NV630-SW



Type NV630-SW

Type name	NV630-CW	NV630-SW		
Number of poles	3			
Rated operational voltage Ue (V AC)	100-440 Multi-voltage type			
Rated current In (Amp.)	500 600 630			
High-speed type	Rated current sensitivity IΔn (mA)	100 · 200 · 500 Selectable		
	Max. operating time at 5IΔn (s)	0.04		
Time-delay type	Rated current sensitivity IΔn (mA)	100 · 200 · 500 Selectable		
	Max. operating time at 5IΔn (s)	0.45 · 1.0 · 2.0 Selectable		
	Max. inertial non-operating time at 2IΔn (s)	0.1 · 0.5 · 1.0		
Earth-leakage indication system	Button			
Rated short-circuit breaking capacity (kA) IEC 60947-2 2nd. ed. (Icu/Ics)	AC	440V	36/18	42/42
		400V	36/18	50/50
		230V	50/25	85/85
Standard Attached Parts (Front connection)	Mounting screw: M6×72 (4pcs) Insulation barrier: (4pcs)			

Operating Characteristics

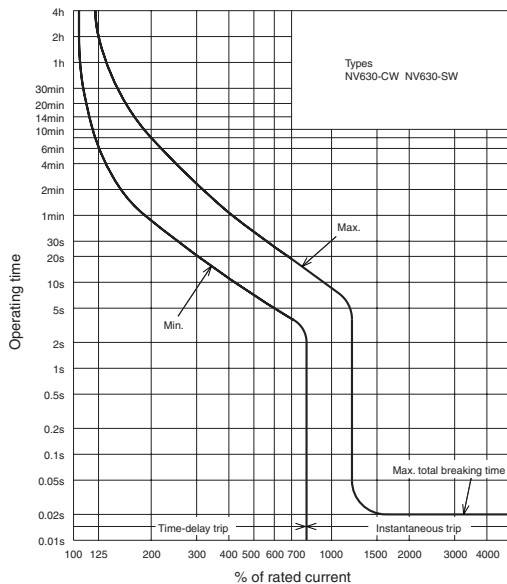

Earth-Leakage Tripping Characteristics

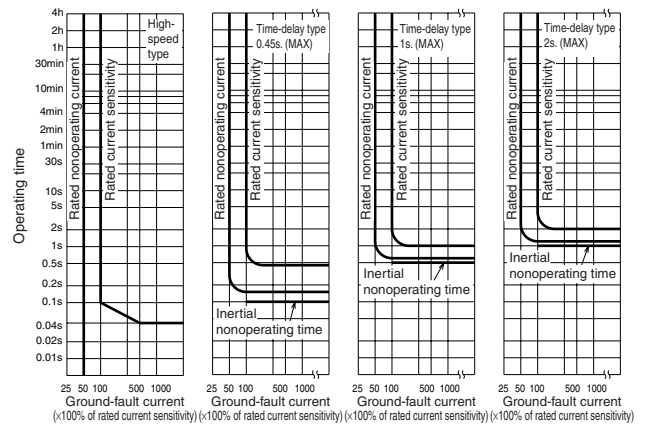

Internal Accessories

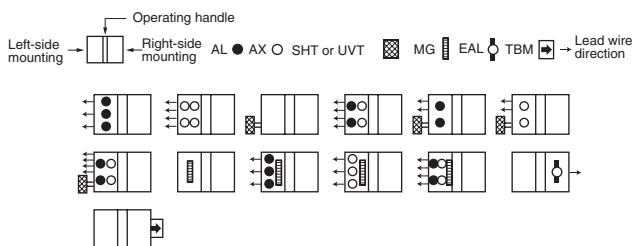

Remark: 1. Refer to page 50 and 51.

External Accessories

External Accessories (An order for ☆ should be placed at the same time as an order of circuit breaker main body.)

Accessories	Type name	Reference page	Accessories	Type name	Reference page
Operating handle	F F-4S	62	Terminal cover	Large (TC-L) TCL-4SW3	70
	V V-4S	65	Skeleton (TTC) TTC-4SW3		
	S S4SW	68	Rear (BTC) BTC-4SW3		
Mechanical interlock (MI)	MI-4SW3	79	Handle lock device	HL HL-4SW	80
Auxiliary handle (HT)	HT-4SW	80		HL-S HLS-4SW	
			Electrical operation device	☆	71

Ambient Compensating Curve

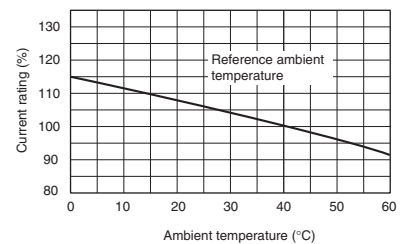

Internal Wiring Diagram

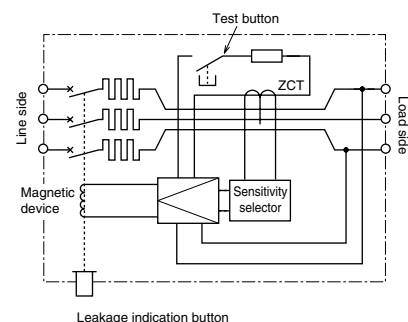

Front connection

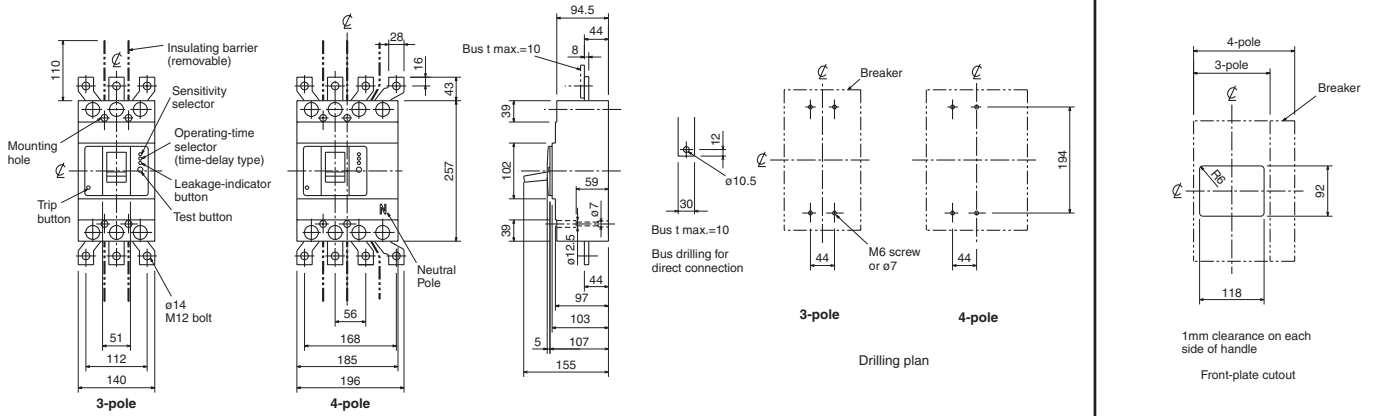

Rear connection

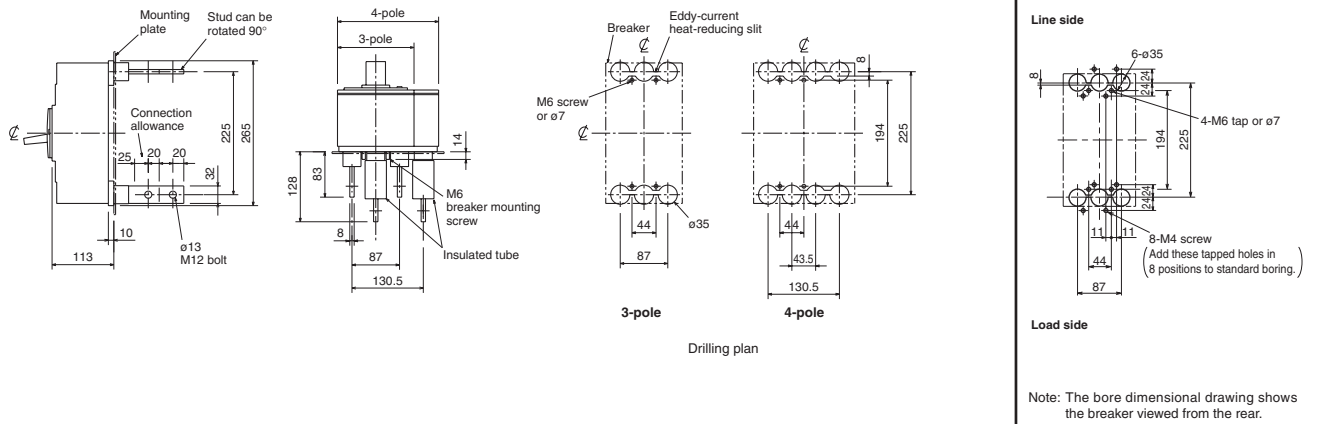

Plug-in

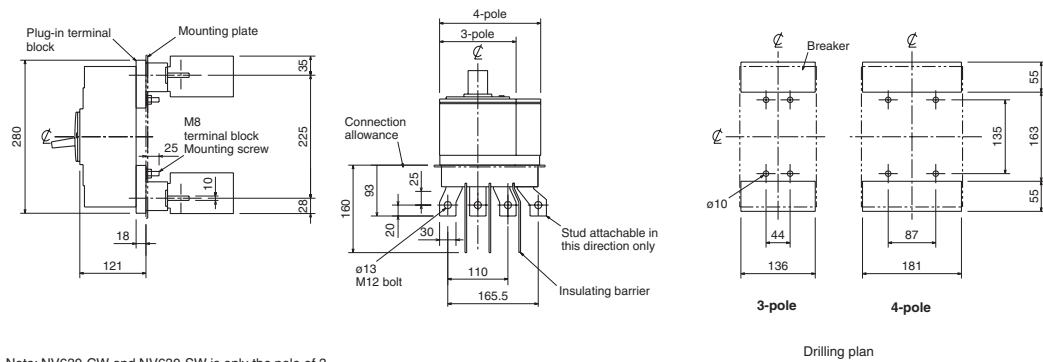

6. Characteristics and Dimensions

Earth-Leakage Circuit Breakers

NV630-SEW
NV630-HEW



Type NV630-SEW

Type name		NV630-SEW	NV630-HEW
Number of poles		3	4
Rated operational voltage U_e (V AC) (#1)		100-440 Multi-voltage type	
Rated current I_n (Amp.)		300-630 adjustable	
High-speed type	Rated current sensitivity $I_{\Delta n}$ (mA)	100 · 200 · 500 Selectable	
	Max. operating time at $5I_{\Delta n}$ (s)	0.04	
Time-delay type	Rated current sensitivity $I_{\Delta n}$ (mA)	(100 · 200 · 500 Selectable)	
	Max. operating time at $5I_{\Delta n}$ (s)	(0.45 · 1.0 · 2.0 Selectable)	
	Max. inertial non-operating time at $2I_{\Delta n}$ (s)	(0.1 · 0.5 · 1.0)	
Earth-leakage indication system		Button	
Rated short-circuit breaking capacity (kA) IEC 60947-2 2nd. ed. (I_{cu}/I_{cs})	AC	440V	42/42
		400V	50/50
		230V	85/85
Standard Attached Parts (Front connection)		Mounting screw: M6×72 (4pcs) Insulation barrier: (3P: 4pcs, 4P: 6pcs)	

Note (#1) Rated operational voltage of time-delay type is for 200-440V.

Operating Characteristics

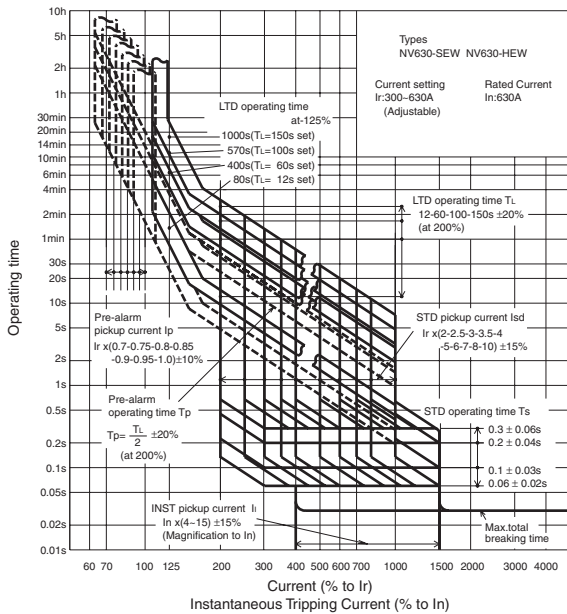

Earth-Leakage Tripping Characteristics

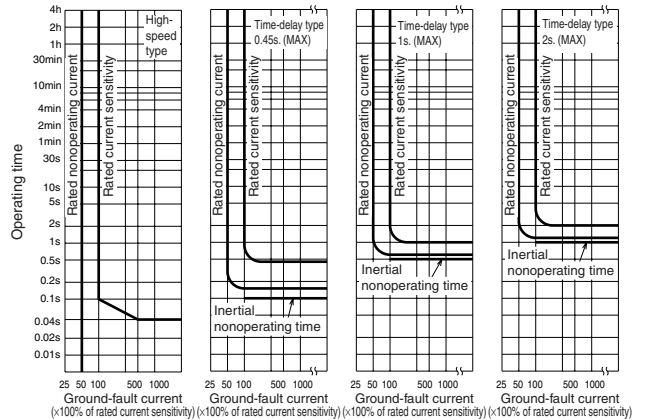

Internal Accessories

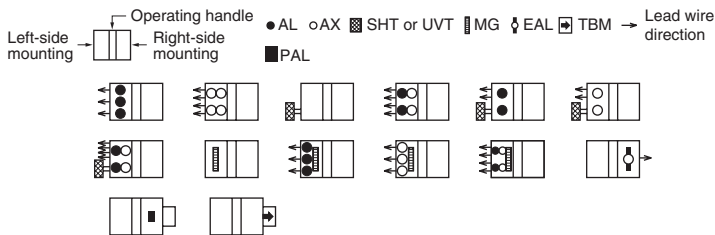

Remark: 1. Instead of EAL and TBM, pre-alarm module (PAL) can be attached.
2. Refer to page 50 and 51.

External Accessories

(An order for ☆ should be placed at the same time as an order of circuit breaker main body.)

Accessories	Type name	Reference page	Accessories	Type name	Reference page
Operating handle	F F-4S	62	Terminal cover	Large (TC-L) TCL-4SW3 (#1)(#2)	70
	V V-4S	65		Skeleton (TTC) TTC-4SW3 (#2)	
	S S4SW	68		Rear (BTC) BTC-4SW3 (#1)(#2)	
Mechanical interlock (MI)	MI-4SW3 (#1)	79	Handle lock device	HL HL-4SW	80
Auxiliary handle (HT)	HT-4SW	80		HL-S HLS-4SW	
			Electrical operation device	☆	71

Note (#1) This is for NV630-SEW

(#2) The designation depends on the number of poles. Refer to the reference page.

Current reducing curve

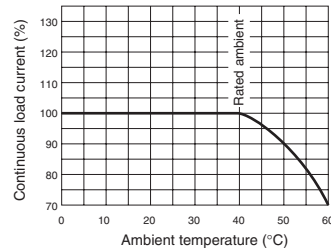

Internal Wiring Diagram

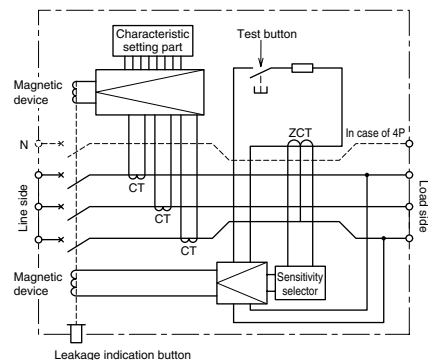

Front connection

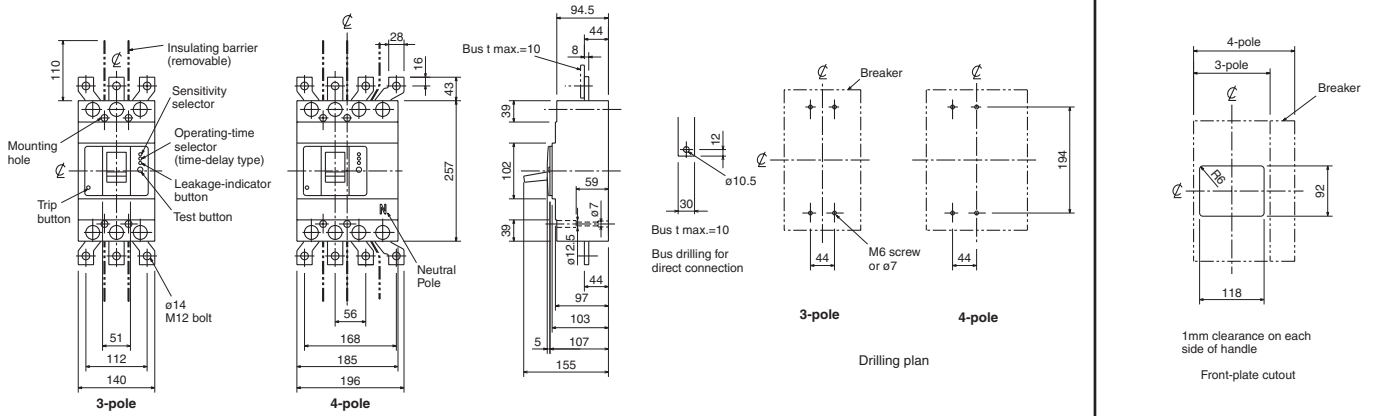

Rear connection

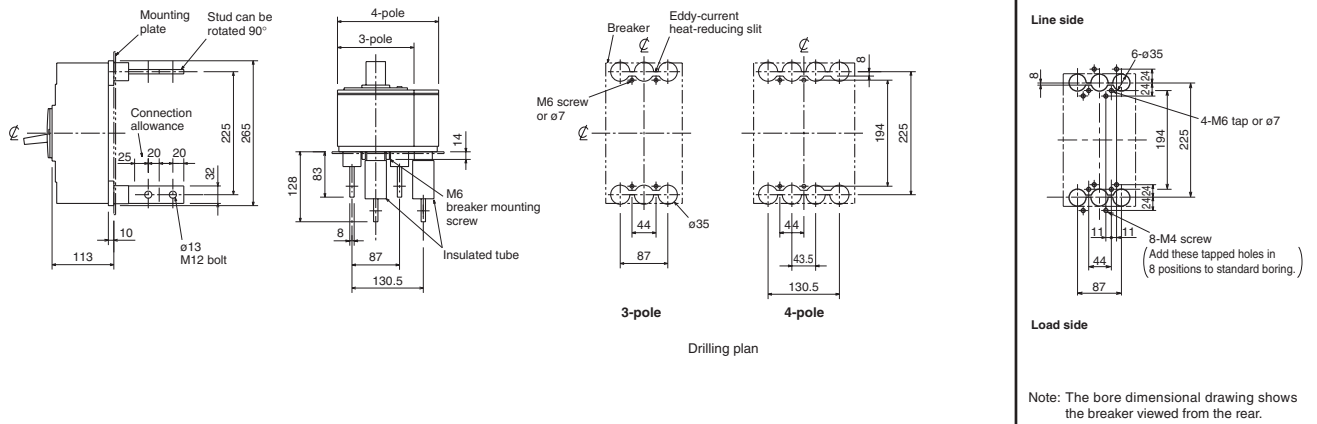

Plug-in

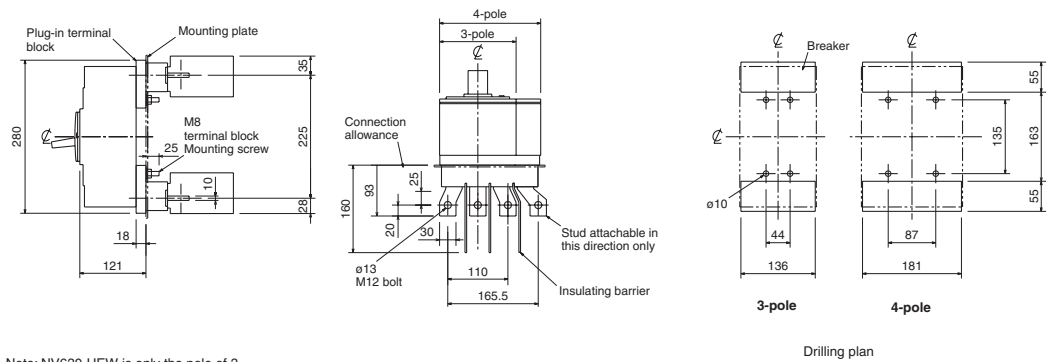

Note: NV630-HEW is only the pole of 3.

Boring dimensions for rear connection type barriers (3-pole)

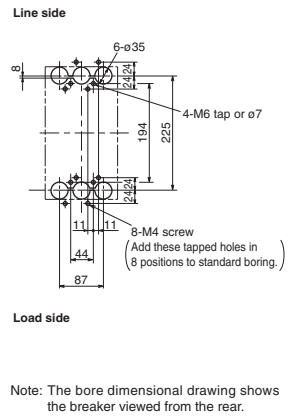

Note: The bore dimensional drawing shows the breaker viewed from the rear.

6. Characteristics and Dimensions

Earth-Leakage Circuit Breakers

NV800-SEW
NV800-HEW



Type NV800-SEW

Type name		NV800-SEW	NV800-HEW	
Number of poles		3		
Rated operational voltage Ue (V AC)		100-440 Multi-voltage type		
Rated current In (Amp.)		400-800 adjustable		
High-speed type	Rated current sensitivity IΔn (mA)	(100 · 200 · 500 Selectable)		
	Max. operating time at 5IΔn (s)	(0.04)		
Time-delay type	Rated current sensitivity IΔn (mA)	100 · 200 · 500 Selectable		
	Max. operating time at 5IΔn (s)	0.45 · 1.0 · 2.0 Selectable		
	Max. inertial non-operating time at 2IΔn (s)	0.1 · 0.5 · 1.0		
Earth-leakage indication system		Button		
Rated short-circuit breaking capacity (kA) IEC 60947-2 2nd. ed. (Icu/Ics)	AC	440V	42/42	65/65
		400V	50/50	70/70
		230V	85/85	100/100
Standard Attached Parts (Front connection)		Mounting screw: M6x35 (4pcs) Insulation barrier: (2pcs)		

Operating Characteristics

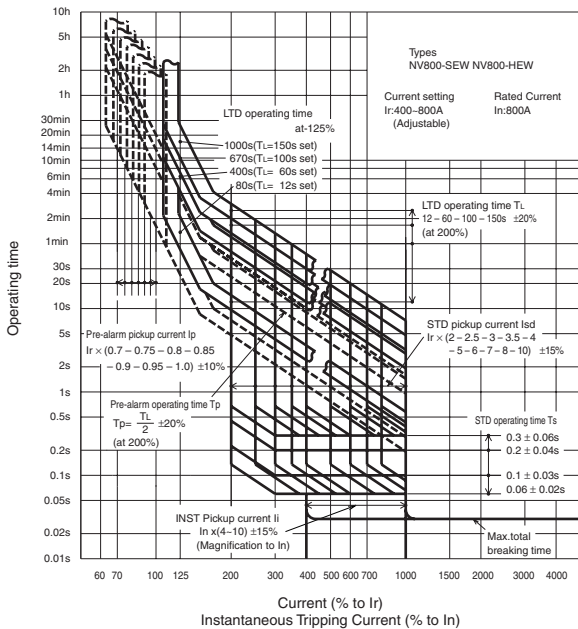

Earth-Leakage Tripping Characteristics

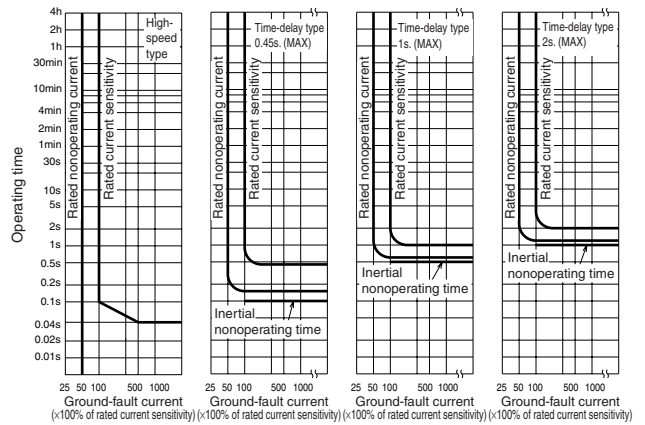

Internal Accessories

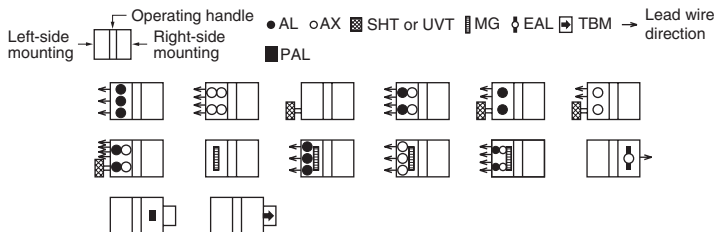

Remark: 1. Instead of EAL and TBM, pre-alarm module (PAL) or trip indicator (TI) can be attached.
2. Refer to page 50 and 51.

External Accessories

(An order for ☆ should be placed at the same time as an order of circuit breaker main body.)

Accessories	Type name	Reference page	Accessories	Type name	Reference page
Operating handle	F F-8S	62	Terminal cover	Large (TC-L) TCL-8SW3	70
	V V-8S	65		Skeleton (TTC) TTC-8SW3	
	S S4SW	68		Rear (BTC) BTC-8SW3	
Mechanical interlock (MI)	MI-8SW3	79	Handle lock device	HL HL-4SW HL-S HLS-8SW	80
Auxiliary handle (HT)	HT-4SW	80	Electrical operation device	☆	71

Current reducing curve

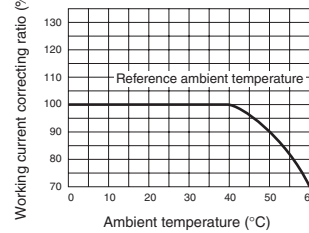

Internal Wiring Diagram

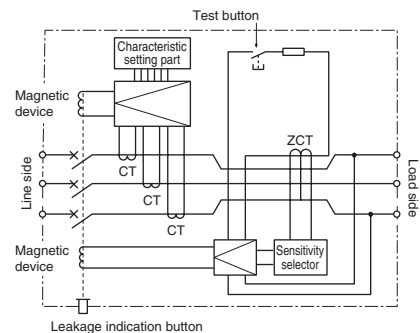

Front connection

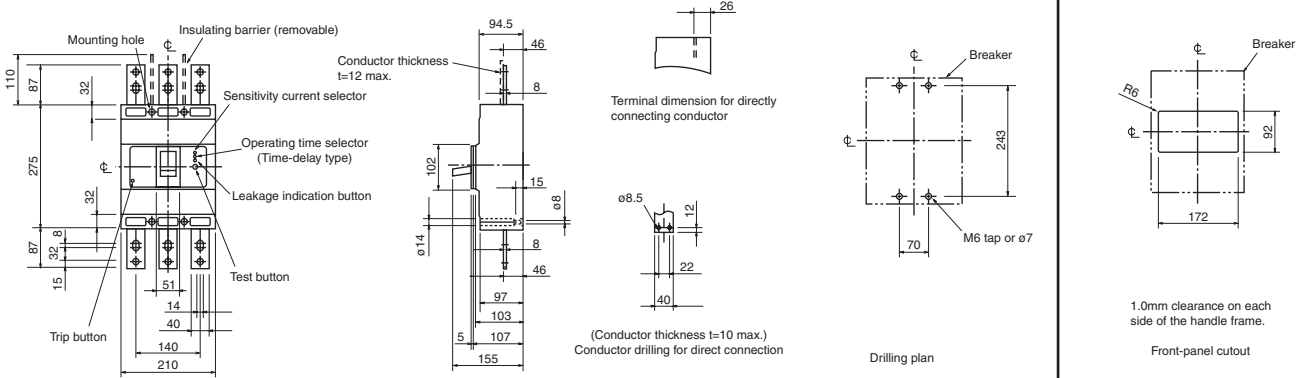

Rear connection

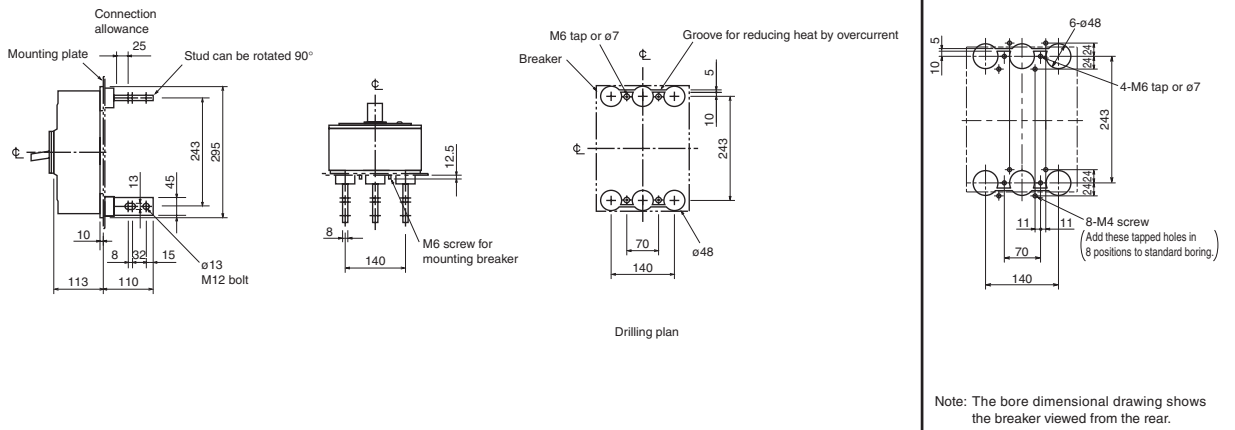

Plug-in

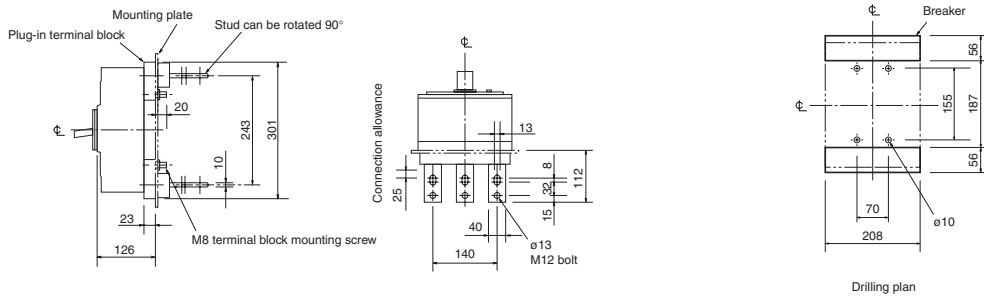

6. Characteristics and Dimensions

Earth-Leakage Circuit Breakers for CE Marking

NV32-SW NV63-CW
 NV63-SW NV63-HW



Type NV63-SW

Type name	NV32-SW	NV63-CW	NV63-SW	NV63-HW
Rated current In (Amp.)	(5) 6 10 (15) 16 20 25 (30) 32	(5) (10) (15) 16 20 25 (30) 32 40 50 (60) 63	(5) (10) (15) 16 20 25 (30) 32 40 50 (60) 63	(15) 16 20 25 (30) 32 40 50 (60) 63
Number of poles	3	3	3	3
Rated operational voltage Ue (V AC)	100-440 Multi-voltage type	100-440 Multi-voltage type	100-440 Multi-voltage type	100-440 Multi-voltage type
High-speed type	Rated current sensitivity IΔn (mA)	30,100•200•500 Selectable	30,100•200•500 Selectable	30,100•200•500 Selectable
	Max. operating time at 5IΔn (s)	0.04	0.04	0.04
Earth-leakage indication system		Button	Button	Button
Rated short-circuit breaking capacity (kA) IEC 60947-2 (Icu/Ics) EN 60947-2	AC440V	5/2	2.5/1	7.5/4
	AC400V	5/2	5/2	7.5/4
	AC230V	10/5	7.5/4	15/8
Standard Attached Parts (Front connection)		Mounting screw: M4×0.7×55 (2pcs) Insulation barrier: (3P: 2pcs) excluding models of NV63-CW		

Operating Characteristics

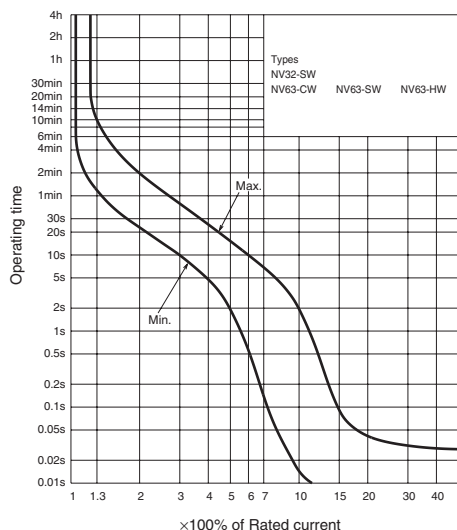

Earth-Leakage Tripping Characteristics

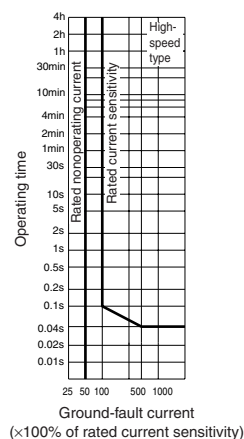

Internal Accessories

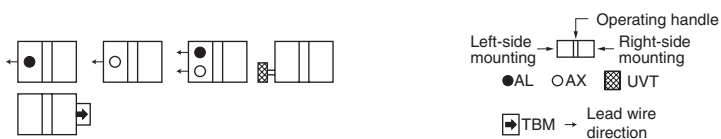

Remark: 1. Refer to page 52.

Temperature Characteristics

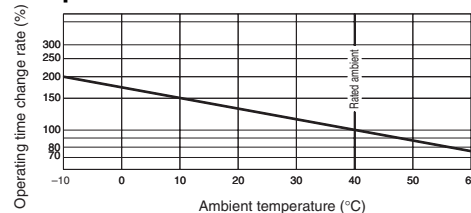

External Accessories

Accessories	Type name	Reference page	Accessories	Type name	Reference page
Operating handle	F F-05S	61	Mechanical interlock	MI MI-05SW3 (#1)	79
	V V-05S	64		Terminal cover	Small TC-S TCS-05SW3W
	S S05SW	68	Large TC-L TCL-05SW3W		
Handle lock device	(#1) HLF-05SW	80	Skeleton TTC TTC-05SW3		
	HL HLN-05SW		Rear BTC BTC-05SW3W		
	HL-S HLS-05SW		Plug-in PTC PTC-05SW3W		
	IEC 35mm rail mounting adapters		DIN-05SW	80	

Internal Wiring Diagram

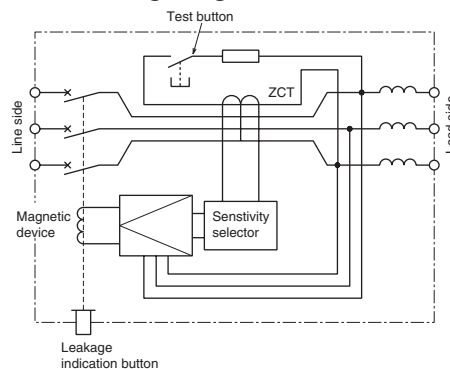

Note (#1) HLF and HLS types are used for OFF-lock, and HLN types for ON-lock.

Front connection

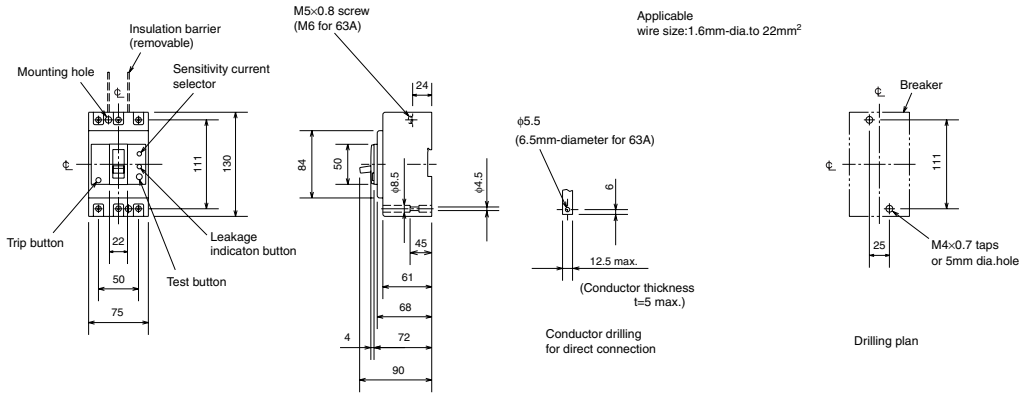

Rear connection

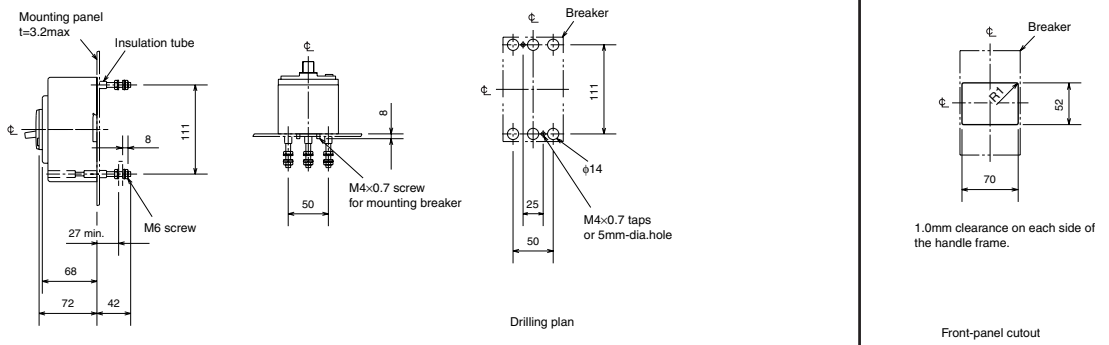

6. Characteristics and Dimensions

Earth-Leakage Circuit Breakers for CE Marking

NV125-CW NV125-SW
NV125-HW



Type NV125-SW

Type name	NV125-CW	NV125-SW	NV125-HW
Rated current In (Amp.) (*1)	63 (75) 80 100 125	(15) 16 20 (30) 32 40 50 (60) 63 (75) 80 100 (125 *2)	(15) 16 20 (30) 32 40 50 (60) 63 (75) 80 100
Number of poles	3	3 4	3 4
Rated operational voltage Ue (V AC) (*3)	100-440 Multi-voltage type	100-440 200-440 Multi-voltage type Multi-voltage type	100-440 200-440 Multi-voltage type Multi-voltage type
High-speed type	Rated current sensitivity $I\Delta n$ (mA)	30,100•200•500 Selectable	30,100•200•500 Selectable
	Max. operating time at $5I\Delta n$ (s)	0.04	0.04
Time-delay type	Rated current sensitivity $I\Delta n$ (mA)	(100•200•500) Selectable	(100•200•500) Selectable
	Max. operating time at $5I\Delta n$ (s)	(0.45•1.0•2.0) Selectable	(0.45•1.0•2.0) Selectable
	Inertial non-operating time at $2I\Delta n$ (s)	(0.1•0.5•1.0)	(0.1•0.5•1.0)
Earth-leakage indication system	Button	Button	Button
Rated short-circuit breaking capacity (kA) IEC 60947-2 (Icu/Ics) EN 60947-2	AC440V	10/5	25/13
	AC400V	10/5	30/15
	AC230V	30/15	50/25
Standard Attached Parts (Front connection)	Mounting screw: M4×0.7×55 (3P: 2pcs, 4P: 4pcs) Insulation barrier: (3P: 2pcs, 4P: 3pcs) excluding models of NV125-CW		

Note (*1) The time-delayed types will be produced when they have the current specifications of 20A or more.
(*2) 3P only
(*3) Rated operational voltage of time-delay type is for 200-440V.

Operating Characteristics

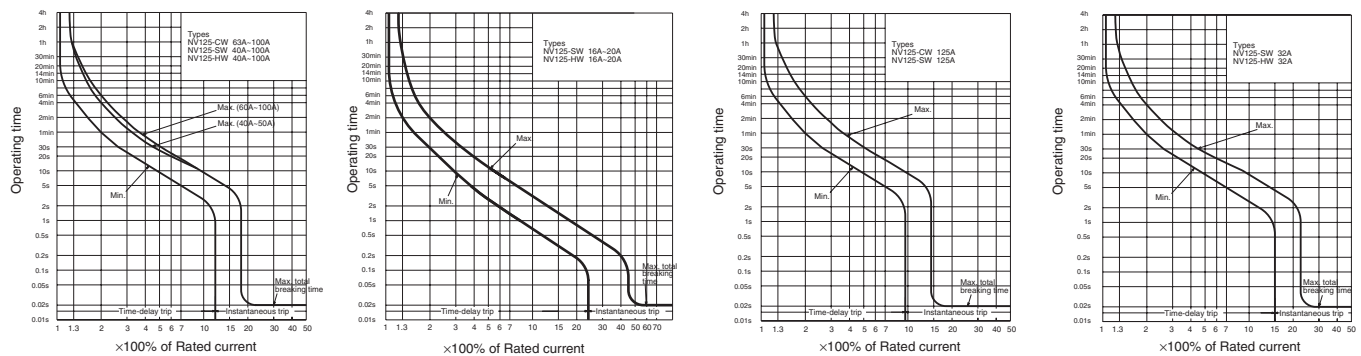

Earth-Leakage Tripping Characteristics

Internal Accessories

Temperature Characteristics

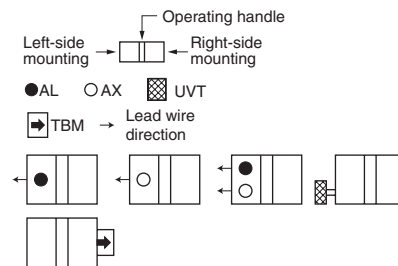
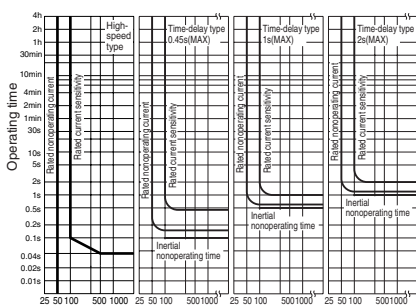

Remark: 1. refer to page 52.

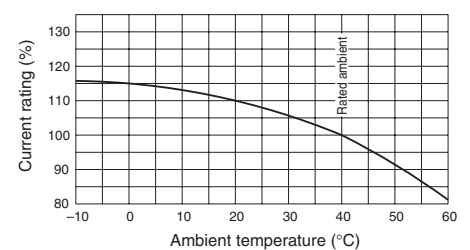

External Accessories

Accessories	Type name	Reference page	Accessories	Type name	Reference page	
Operating handle	F F-1S	61	Mechanical interlock	MI MI-05SW3 (*3)	79	
	V V-1S	64		Terminal cover	Small TC-S TCS-1SW3W (*3)	70
	S S1SW	68			Large TC-L TCL-1SW3W (*3)	
Handle lock device	(*)1 HLF-1SW	80			Skeleton TTC TTC-1SW3 (*3)	
	HL HLN-1SW				Rear BTC BTC-1SW3W (*3)	
	HL-S HLS-1SW		Plug-in PTC PTC-1SW3W (*3)			
IEC 35mm rail mounting adapters			DIN-1SW (*3)	80		
Electrical operation device			MDS-NV1SWE (*2)	71		

Internal Wiring Diagram

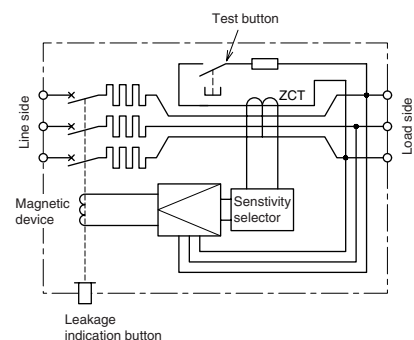

Note (*1) HLF and HLS types are used for OFF-lock, and HLN types for ON-lock.
(*2) Specify the working voltage.
(*3) The designation depends on the number of poles. Refer to the reference page.

Front connection

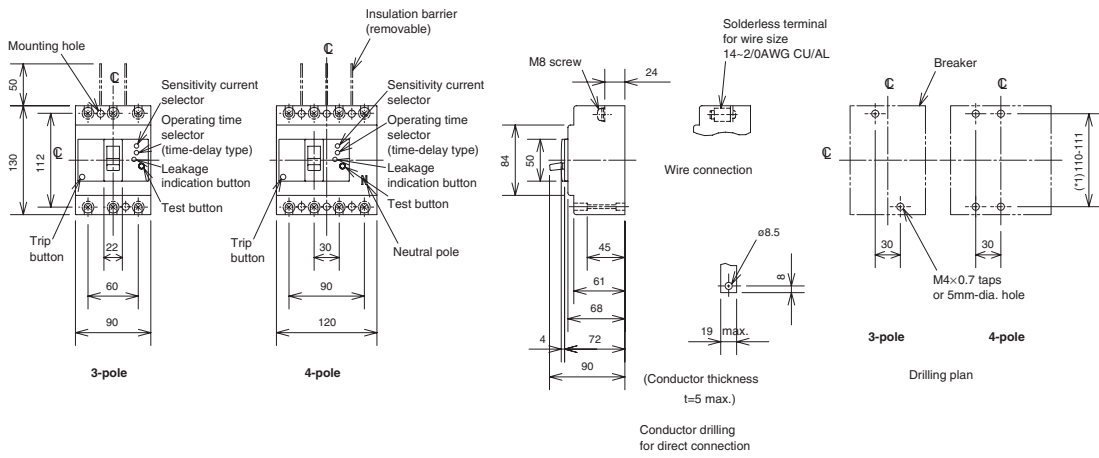

Rear connection

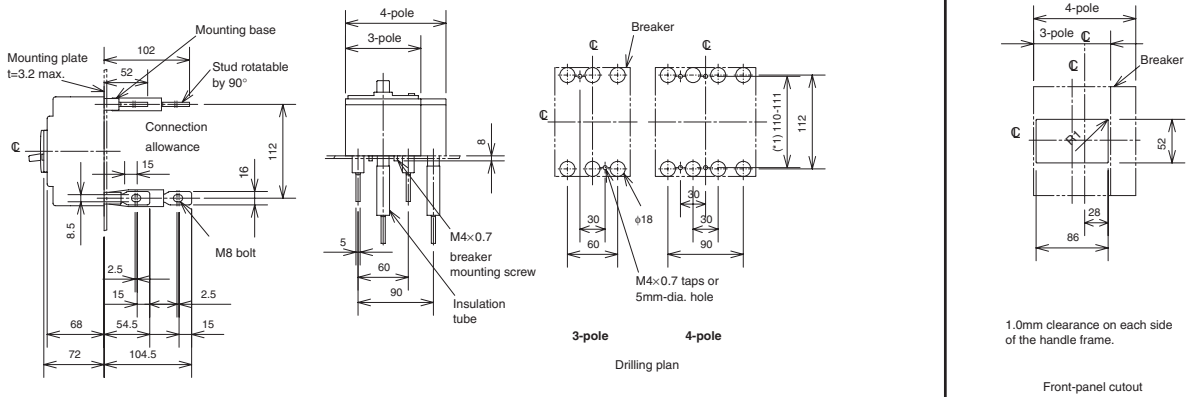

Note (*1) It can respond to the attachment size of 110 and 111 both sides.

Remark: 1. NV125-CW is available in 3-pole only.

6. Characteristics and Dimensions

Earth-Leakage Circuit Breakers for CE Marking

NV250-CW NV250-SW
NV250-HW



Type NV250-SW

Type name		NV250-CW	NV250-SW	NV250-HW
Rated current I _n (Amp.)		125 150 175 200 225 250	125 150 175 200 225 250	125 150 175 200 225
Number of poles		3	3	4
Rated operational voltage U _e (V AC) (*1)		100-440 Multi-voltage type	100-440 Multi-voltage type	200-440 Multi-voltage type
High-speed type	Rated current sensitivity I _{Δn} (mA)	30, 100•200•500 Selectable	30, 100•200•500 Selectable	30, 100•200•500 Selectable
	Max. operating time at 5I _{Δn} (s)	0.04	0.04	0.04
Time-delay type	Rated current sensitivity I _{Δn} (mA)	(100•200•500) Selectable	(100•200•500) Selectable	(100•200•500) Selectable
	Max. operating time at 5I _{Δn} (s)	(0.45•1.0•2.0) Selectable	(0.45•1.0•2.0) Selectable	(0.45•1.0•2.0) Selectable
	Inertial non-operating time at 2I _{Δn} (s)	(0.1•0.5•1.0)	(0.1•0.5•1.0)	(0.1•0.5•1.0)
Earth-leakage indication system		Button	Button	Button
Rated short-circuit breaking capacity (kA) IEC 60947-2 (I _{cu} /I _{cs}) EN 60947-2	AC440V	15/8	25/13	50/13
	AC400V	18/9	30/15	50/13
	AC230V	35/18	50/25	100/25
Standard Attached Parts (Front connection)		Mounting screw: M4×0.7×55 (3P: 2pcs, 4P: 4pcs) Insulation barrier: (3P: 4pcs, 4P: 6pcs)		

Note (*1) Rated operational voltage of time-delay type is for 200-440V.

Operating Characteristics

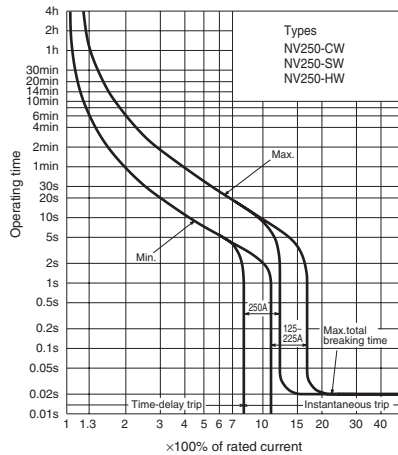

Earth-Leakage Tripping Characteristics

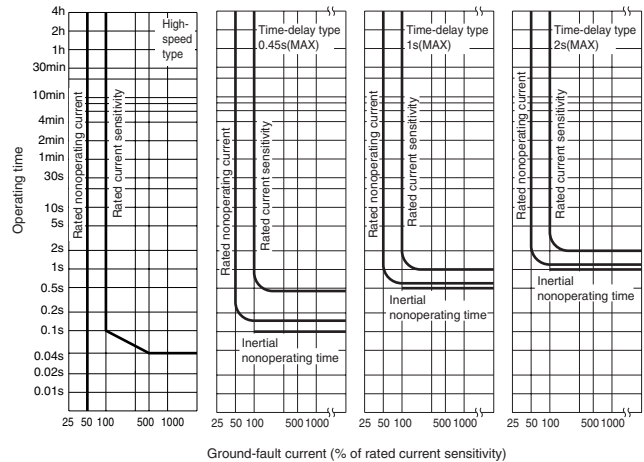

Internal Accessories

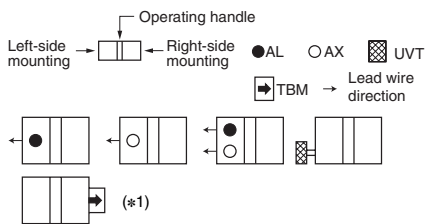

Note (*1) Refer to page 52.

Temperature Characteristics

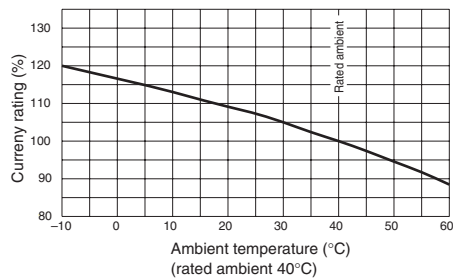

External Accessories

Accessories	Type name	Reference page	Accessories	Type name	Reference page	
Operating handle	F F-2S	61	Mechanical interlock	MI MI-05SW3 (*2)	79	
	V V-2S	64		Terminal cover	Small TC-S TCS-2SW3W (*2)	70
	S S2SW	68			Large TC-L TCL-2SW3W (*2)	
Handle lock device	LC LC-2SW	80	Skeleton TTC TTC-2SW3 (*2)			
	(*)1 HLF HLF-2SW		Rear BTC BTC-2SW3W (*2)			
	HL HLN-2SW		Plug-in PTC PTC-2SW3W (*2)			
	HL-S HLS-2SW		Electrical operation device	MDS-NV2SWE (*3)	71	

Note (*1) HLF types are used for OFF-lock, and HLN types for ON-lock.
(*2) The designation depends on the number of poles. Refer to the reference page.
(*3) Specify the working voltage.

Internal Wiring Diagram

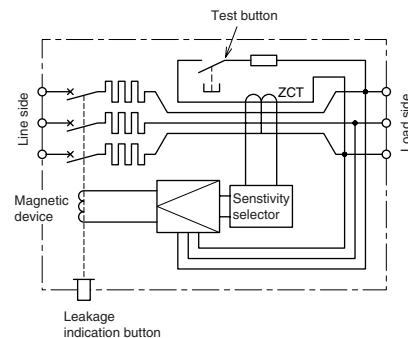

Front connection

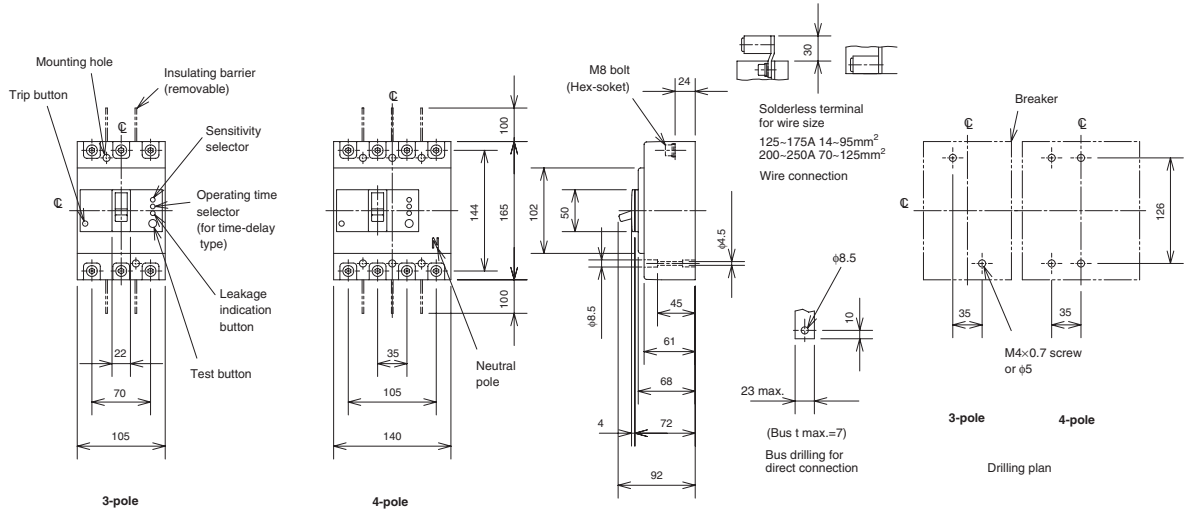

Rear connection

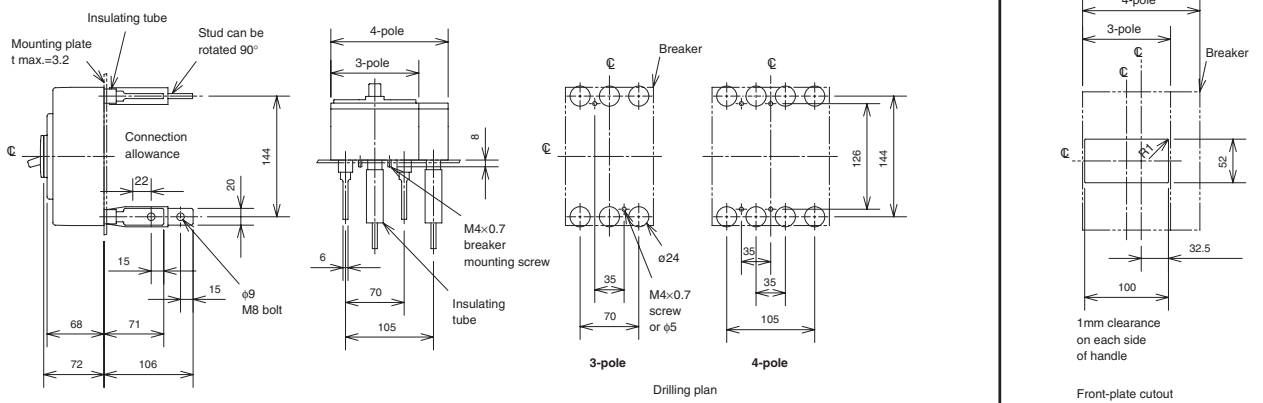

Remark: 1. NV250-CW are available in 3-pole only.

6. Characteristics and Dimensions

Earth-Leakage Circuit Breakers for CE Marking

NV125-RW



Type NV125-RW

Type name		NV125-RW
Rated current In (Amp.)		(15) 16 20 (30) 32 40 50 (60) 63 (75) 80 100
Number of poles		3
Rated operational voltage Ue (V AC) (*2)		100-440 Multi-voltage type
High-speed type	Rated current sensitivity IΔn (mA)	(30) 100•200•500 Selectable
	Max. operating time at 5IΔn (s)	0.04
Time-delay type	Rated current sensitivity IΔn (mA)	(100•200•500) Selectable
	Max. operating time at 5IΔn (s)	(0.45•1.0•2.0) Selectable
	Inertial non-operating time at 2IΔn (s)	(0.1•0.5•1.0)
Earth-leakage indication system		Button
Rated short-circuit breaking capacity (kA) IEC 60947-2 (Icu/Ics) EN 60947-2	AC440V	125/125
	AC400V	125/125
	AC230V	125/125
Standard Attached Parts (Front connection)		Mounting screw : M4×0.7×73 (4pcs) Insulation barrier : (3P:4pcs, 4P:6pcs)

Note (*1) The Time-delayed types will be produced when they have the current specifications of 20A or more.

Note (*2) Rated operational voltage of time-delay type is for 200-440V.

Operating Characteristics

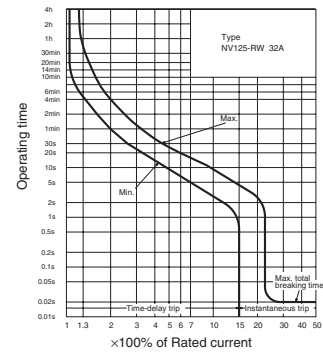
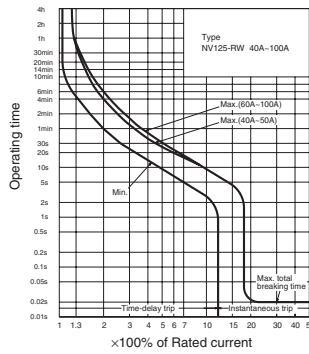
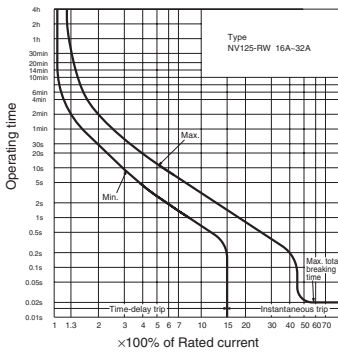

Earth-Leakage Tripping Characteristics

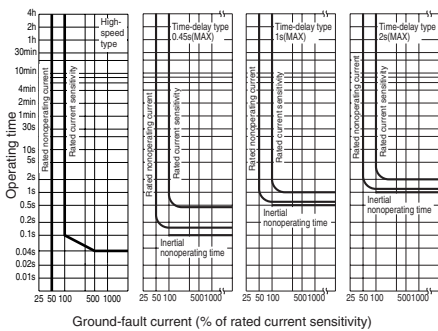

Internal Accessories

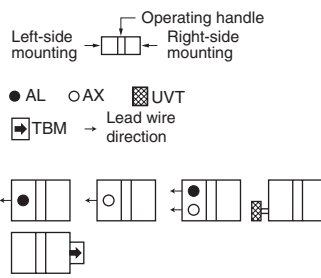

Remark: 1. Refer to page 52.

Temperature Characteristics

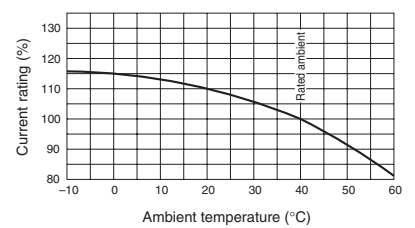

External Accessories

Accessories	Type name	Reference page	Accessories	Type name	Reference page
Operating handle	F F-1U	61	Terminal cover	Small TC-S	TCS-1SW3W (*1)
	V V-1U	64		Large TC-L	TCL-1SW3W (*1)
	S S1SW	68		Skeleton TTC	TTC-1SW3 (*1)
Mechanical interlock	MI MI-05SW3 (*1)	79		Rear BTC	BTC-1SW3W (*1)
	Electrical operation device	—		Plug-in PTC	PTC-1SW3W (*1)
Handle lock device	LC LC-1SW	80	LC LC-1SW	LC-1SW	
	(*2) HLF-1SW		HLF-1SW		
	HLN-1SW		HLN-1SW		
	HL-S	HLS-1SW			

Note (*1) The designation depends on the number of poles. Refer to the reference page.

(*2) HLF and HLS types are used for OFF-lock, and HLN types for ON-lock.

Internal Wiring Diagram

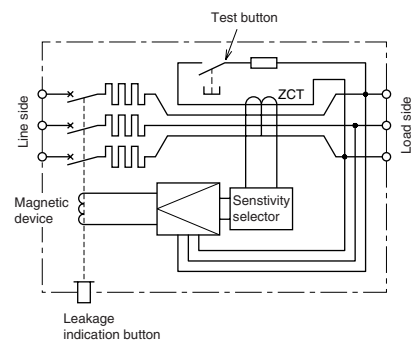

Front connection

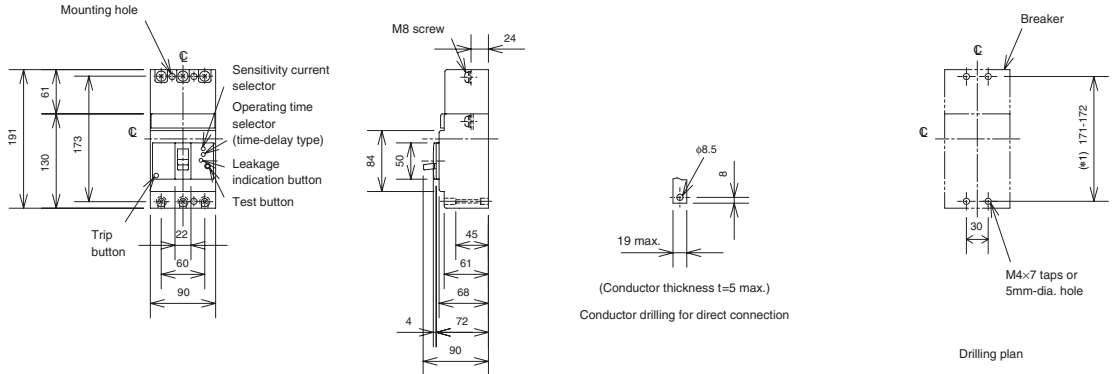

Rear connection

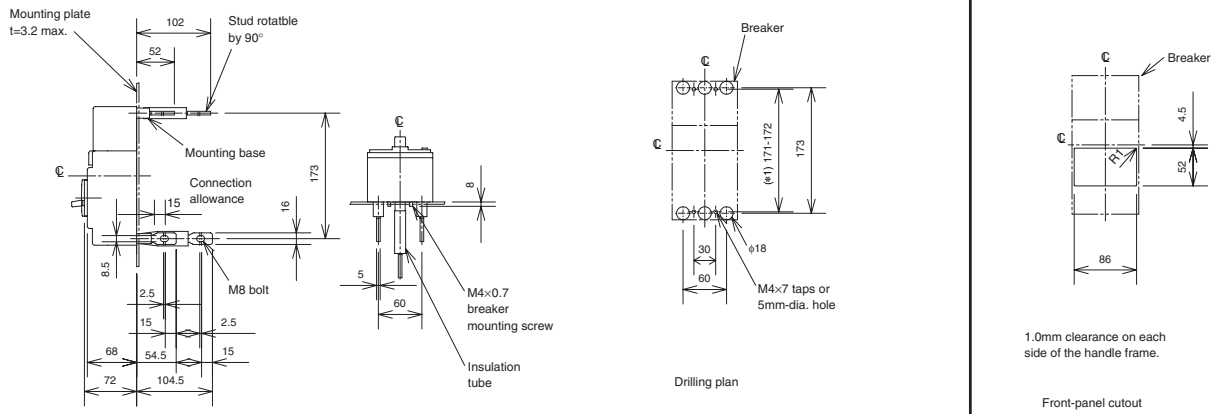

Note (*1) It can respond to the attachment size of 171 and 172 both sides.

6. Characteristics and Dimensions

Earth-Leakage Circuit Breakers for CE Marking

NV250-RW



Type NV250-RW

Type name		NV250-RW	
Rated current In (Amp.)		125 150 175 200 225	
Number of poles		3	
Rated operational voltage Ue (V AC) (*1)		100-440 Multi-voltage type	
High-speed type	Rated current sensitivity IΔn (mA)	(30) 100•200•500 Selectable	
	Max. operating time at 5IΔn (s)	0.04	
Time-delay type	Rated current sensitivity IΔn (mA)	(100•200•500) Selectable	
	Max. operating time at 5IΔn (s)	(0.45•1.0•2.0) Selectable	
	Inertial non-operating time at 2IΔn (s)	(0.1•0.5•1.0)	
Earth-leakage indication system		Button	
Rated short-circuit breaking capacity (kA) IEC 60947-2 (Icu/Ics) EN 60947-2	AC440V	125/125	
	AC400V	125/125	
	AC230V	125/125	
Standard Attached Parts (Front connection)		Mounting screw : M4 × 0.7 × 55 (2pcs), M4 × 0.7 × 73 (2pcs) Insulation barrier : (4pcs)	

Note (*1) Rated operational voltage of time-delay type is for 200-440V

Operating Characteristics

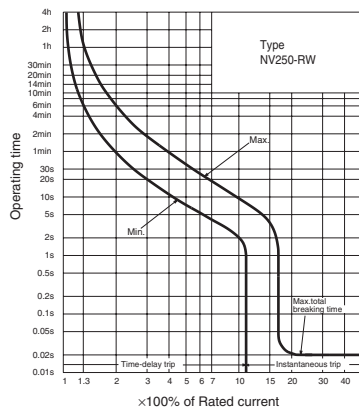

Earth-Leakage Tripping Characteristics

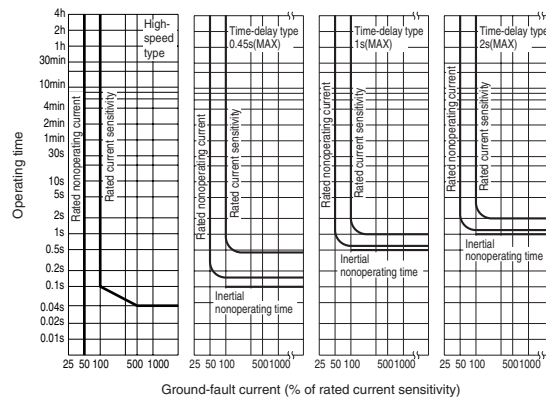

Internal Accessories

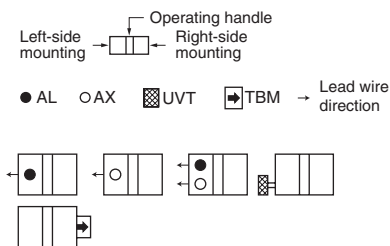

Remark: 1. Refer to page 52.

Ambient Compensating Curve

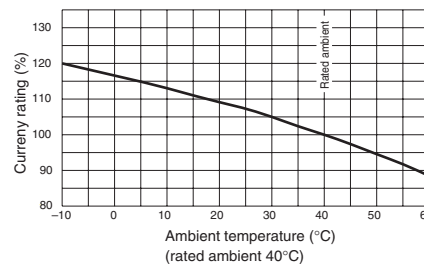

External Accessories

Accessories	Type name	Reference page	Accessories	Type name	Reference page
Operating handle	F F-2U	61	Mechanical interlock	MI MI-05SW3 (*1)	79
	V V-2U	64		Terminal cover	Small TC-S TCS-2SW3W (*1)
	S S2SW	68	Large TC-L TCL-2SW3W (*1)		
Handle lock device	LC LC-2SW	80	Skeleton TTC TTC-2SW3 (*1)		
	(*1) HLF HLF-2SW		Rear BTC BTC-2SW3W (*1)		
	HLN HLN-2SW		Plug-in PTC PTC-2SW3W (*1)		
	HL-S HLS-2SW		Electrical operation device	-	-

Internal Wiring Diagram

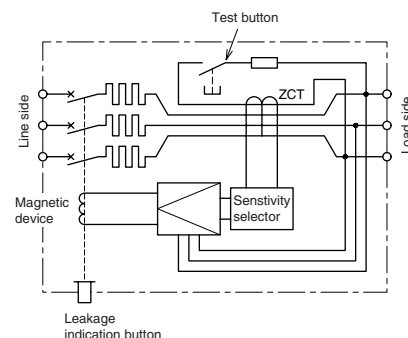

Note (*1) The designation depends on the number of poles. Refer to the reference page.
(*2) HLF types are used for OFF-lock, and HLN types for ON-lock.

Front connection

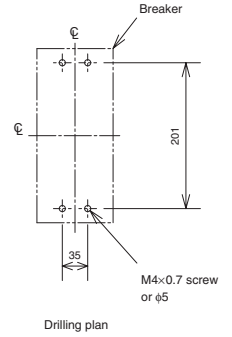
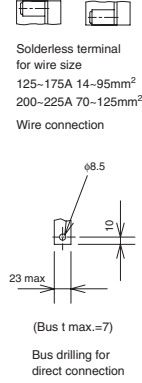
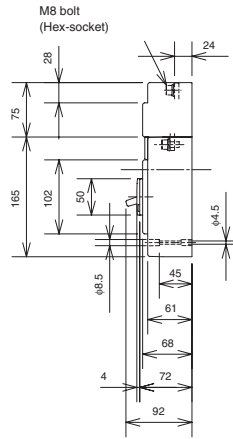
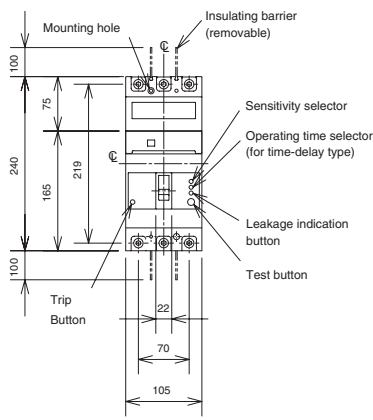

Rear connection

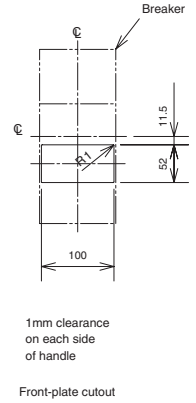
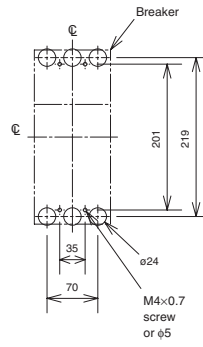
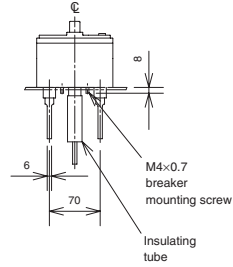
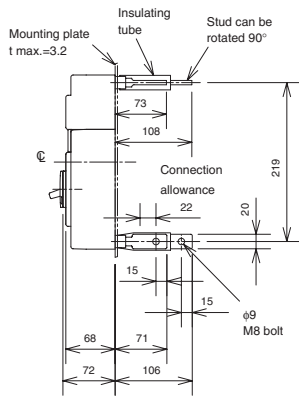

6. Characteristics and Dimensions

Earth-Leakage Circuit Breakers for CE Marking

NV400-CW
NV400-SW



Type NV400-SW

Type name		NV400-CW	NV400-SW
Number of poles		3	
Rated operational voltage Ue (V AC) (#1)		100-440 Multi-voltage type	
Rated current In (Amp.)		250 300 350 400	
High-speed type	Rated current sensitivity ΔIn (mA)	(30) 100 · 200 · 500 Selectable	
	Max. operating time at 5IΔn (s)	0.04	
Time-delay type	Rated current sensitivity ΔIn (mA)	(100 · 200 · 500 Selectable)	
	Max. operating time at 2IΔn (s)	(0.45 · 1.0 · 2.0 Selectable)	
	Inertial non-operating time at 2IΔn (s)	(0.1 · 0.5 · 1.0)	
Earth-leakage indication system		Button	
Rated short-circuit breaking capacity (kA) IEC 60947-2 (Icu/Ics) EN 60947-2	AC	440V	25/13 42/42
		400V	36/18 45/45
		230V	50/25 85/85
Standard Attached Parts (Front connection)		Mounting screw: M6×60 (4pcs) Insulation barrier: (4pcs)	

Note (#1) Rated operational voltage of time-delay type is for 200-440V.

Operating Characteristics

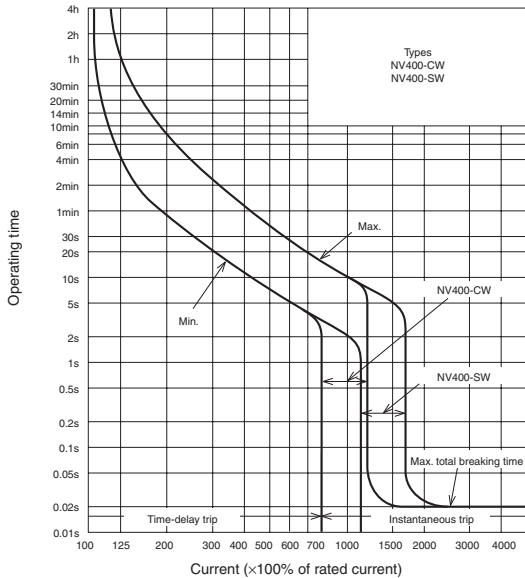

Earth-Leakage Tripping Characteristics

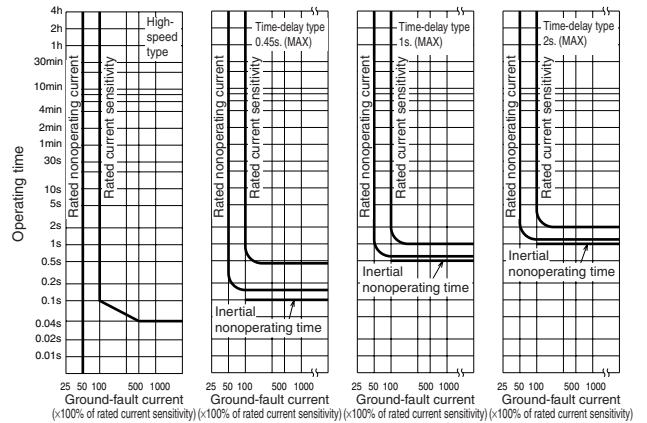

Internal Accessories

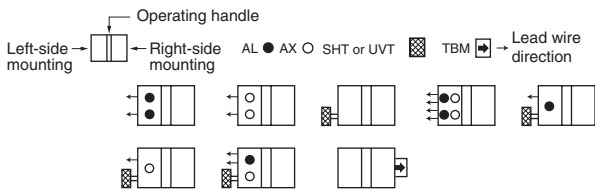

Remark: 1. Refer to page 53.

External Accessories

(An order for ☆ should be placed at the same time as an order of circuit breaker main body.)

Accessories	Type name	Reference page	Accessories	Type name	Reference page
Operating handle	F F-4S	62	Terminal cover	Large (TC-L) TCL-4SW3	70
	V V-4S	65		Skeleton (TTC) TTC-4SW3	
	S S4CW, S4SW	68		Rear (BTC) BTC-4SW3	
Mechanical interlock (MI)	MI-4SW3 (#1)	79	Handle lock device	HL HL-4CW, HL-4SW	80
Auxiliary handle (HT)	HT-4CW, HT-4SW	80	Electrical operation device	☆	71

Note (#1) The designation depends on the number of poles. Refer to the reference page.

Ambient Compensating Curve

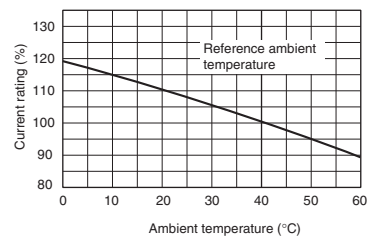

Internal Wiring Diagram

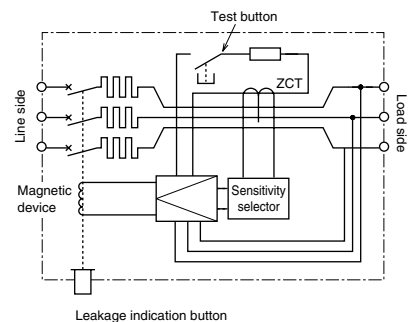

Front connection

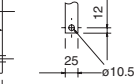
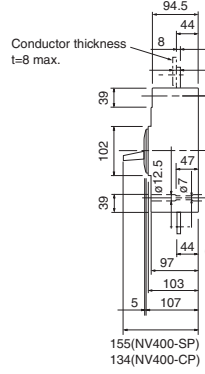
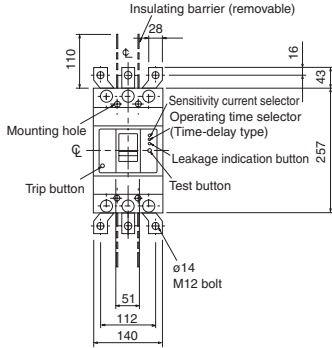

Conductor thickness t=8 max.
Conductor drilling for direct connection

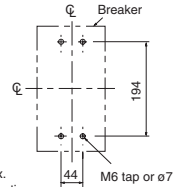

Drilling plan

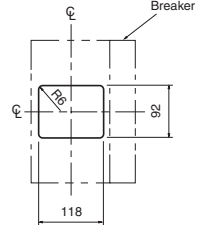

1.0mm clearance on each side of the handle frame.

Front-panel cutout

Rear connection

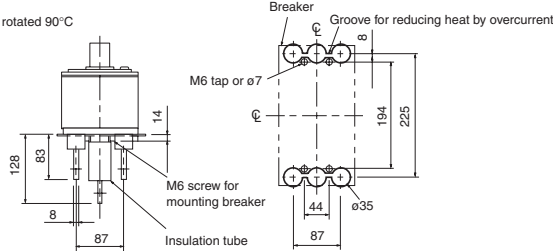
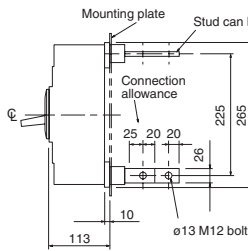

Drilling plan

Boring dimensions for rear connection type barriers (3-pole)

Line side

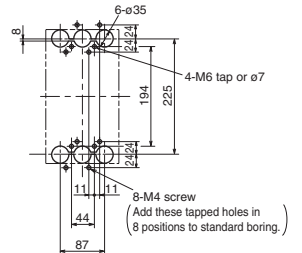

Load side

Note: The bore dimensional drawing shows the breaker viewed from the rear.

6. Characteristics and Dimensions

Earth-Leakage Circuit Breakers for CE Marking

NV400-SEW
NV400-HEW
NV400-REW



Type NV400-SEW

Type name		NV400-SEW		NV400-HEW		NV400-REW	
Number of poles		3	4	3	4	3	
Rated operational voltage Ue (V AC) (*1)		100-440 Multi-voltage type					
Rated current In (Amp.)		200-400 adjustable					
High-speed type	Rated current sensitivity IΔn (mA)	(30) 100 · 200 · 500 Selectable					
	Max. operating time at 5IΔn (s)	0.04					
Time-delay type	Rated current sensitivity IΔn (mA)	(100 · 200 · 500 Selectable)					
	Max. operating time at 5IΔn (s)	(0.45 · 1.0 · 2.0 Selectable)					
	Max. inertial non-operating time at 2IΔn (s)	(0.1 · 0.5 · 1.0)					
Earth-leakage indication system		Button					
Rated short-circuit breaking capacity (kA) IEC 60947-2 (Icu/Ics) EN 60947-2	AC	440V	42/42	65/65	125/63		
		400V	50/50	70/70	125/63		
		230V	85/85	100/100	150/75		
Standard Attached Parts (Front connection)		Mounting screw: M6×72 (4pcs) Insulation barrier: (3P: 4pcs, 4P: 6pcs)					

Note (*1) Rated operational voltage of time-delay type is for 200-440V.

Operating Characteristics

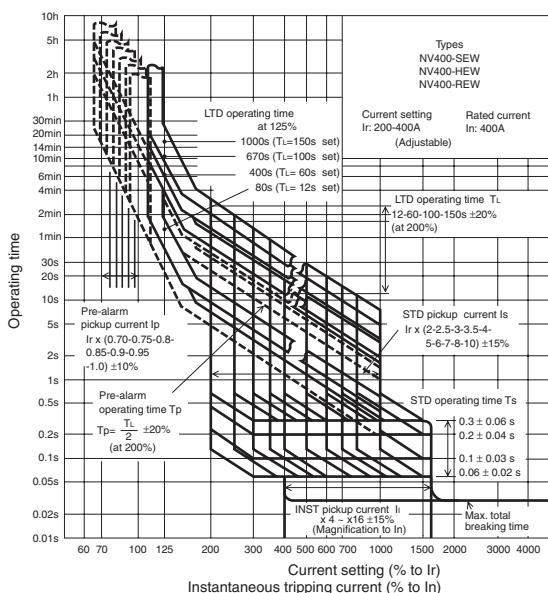

Earth-Leakage Tripping Characteristics

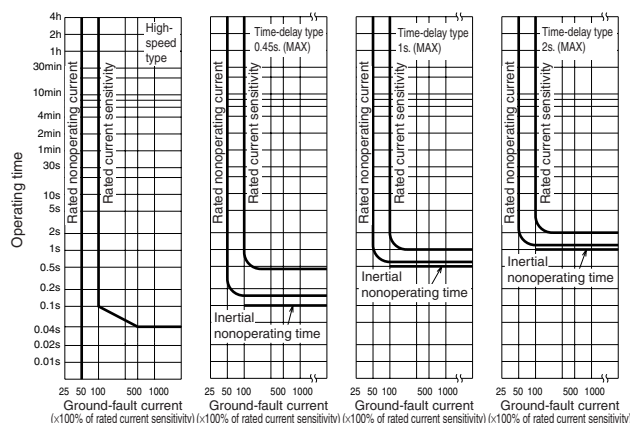

Internal Accessories

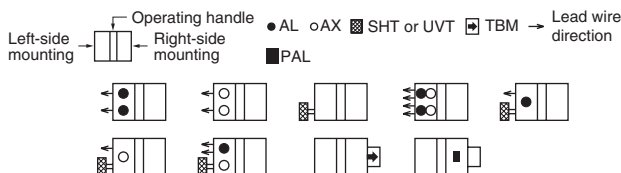

Remark 1. Instead of TBM, pre-alarm module (PAL) can be attached.
2. Refer to page 53.

External Accessories

(An order for ☆ should be placed at the same time as an order of circuit breaker main body.)

Accessories	Type name	Reference page	Accessories	Type name	Reference page
Operating handle	F F-4S	62	Terminal cover	Large (TC-L) TCL-4SW3 (*1) (*2)	70
	V V-4S	65		Skeleton (TTC) TTC-4SW3 (*2)	
	S S4SW	68		Rear (BTC) BTC-4SW3 (*1) (*2)	
Mechanical interlock (MI)	MI-4SW3 (*2)	79	Handle lock device	HL HL-4SW	80
Auxiliary handle (HT)	HT-4SW	80		HL-S HLS-4SW	
			Electrical operation device	☆	71

Note (*1) This is for NV400-SEW.
(*2) The designation depends on the number of poles. Refer to the reference page.

Current reducing curve

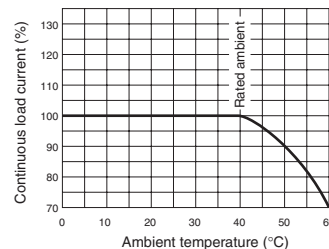

Internal Wiring Diagram

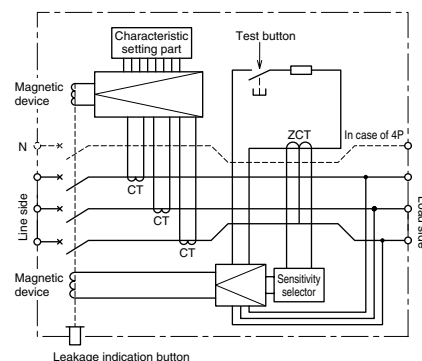

Front connection

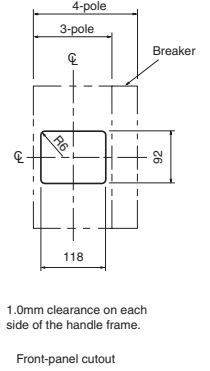
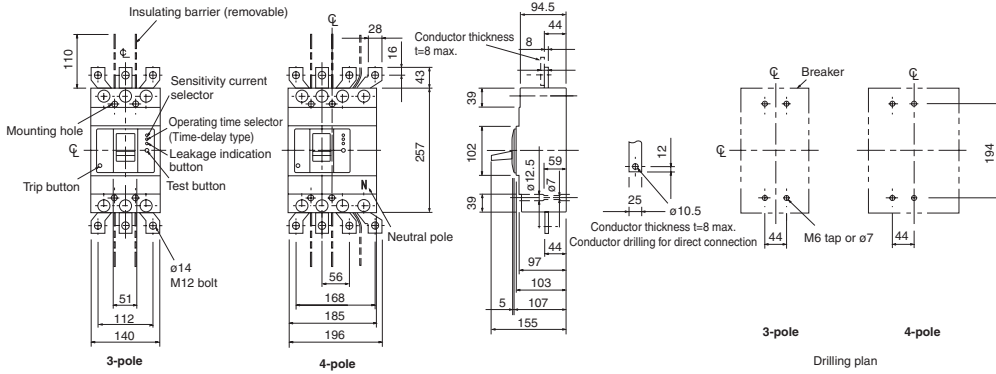

Rear connection

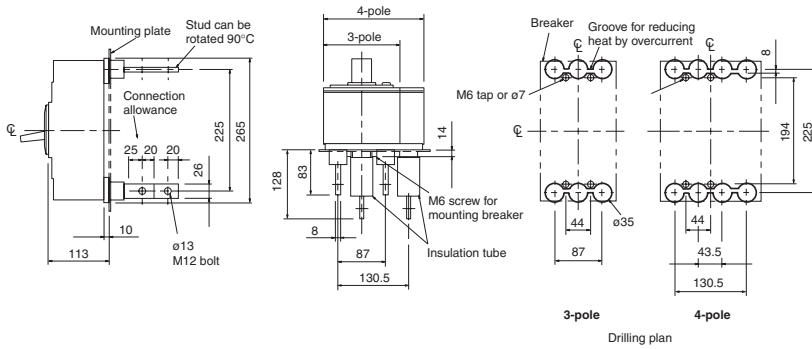

Boring dimensions for rear connection type barriers (3-pole)

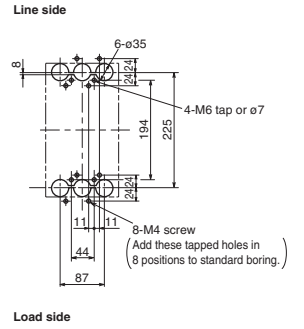

Note: The bore dimensional drawing shows the breaker viewed from the rear.

6. Characteristics and Dimensions

Earth-Leakage Circuit Breakers for CE Marking

NV630-CW NV630-SW



Type NV630-SW

Type name		NV630-CW	NV630-SW
Number of poles		3	
Rated operational voltage Ue (V AC)		100-440 Multi-voltage type	
Rated current In (Amp.)		500 600 630	
High-speed type	Rated current sensitivity IΔn (mA)	100 · 200 · 500 Selectable	
	Max. operating time at 5IΔn (s)	0.04	
Time-delay type	Rated current sensitivity IΔn (mA)	100 · 200 · 500 Selectable	
	Max. operating time at 5IΔn (s)	0.45 · 1.0 · 2.0 Selectable	
	Max. inertial non-operating time at 2IΔn (s)	0.1 · 0.5 · 1.0	
Earth-leakage indication system		Button	
Rated short-circuit breaking capacity (kA) IEC 60947-2 (Icu/Ics) EN 60947-2	AC	440V	36/18
		400V	36/18
		230V	50/25
Standard Attached Parts (Front connection)		Mounting screw: M6x72 (4pcs) Insulation barrier: (4pcs)	

Operating Characteristics

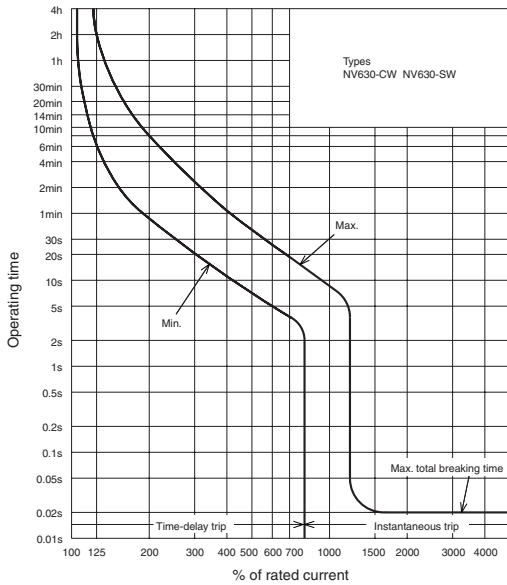

Earth-Leakage Tripping Characteristics

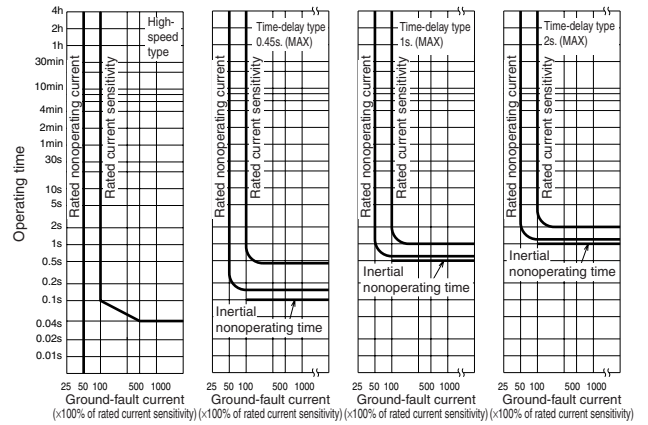

Internal Accessories

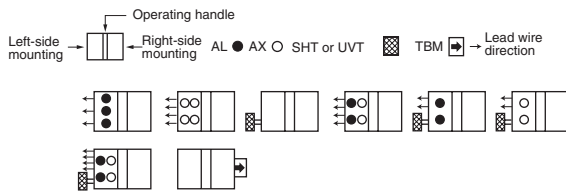

Remark: 1. Refer to page 53.

External Accessories

External Accessories (An order for ☆ should be placed at the same time as an order of circuit breaker main body.)

Accessories	Type name	Reference page	Accessories	Type name	Reference page
Operating handle	F F-4S	62	Terminal cover	Large (TC-L) TCL-4SW3	70
	V V-4S	65		Skeleton (TTC) TTC-4SW3	
	S S4SW	68		Rear (BTC) BTC-4SW3	
Mechanical interlock (MI)	MI-4SW3	79	Handle lock device	HL HL-4SW	80
Auxiliary handle (HT)	HT-4SW	80		HL-S HLS-4SW	
			Electrical operation device	☆	71

Ambient Compensating Curve

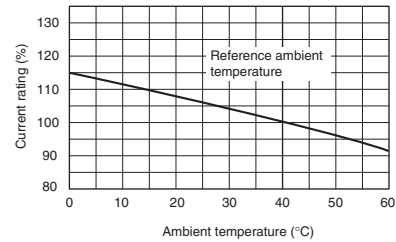

Internal Wiring Diagram

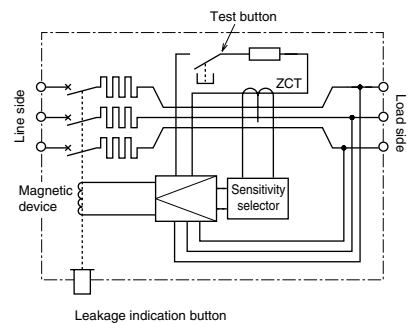

Front connection

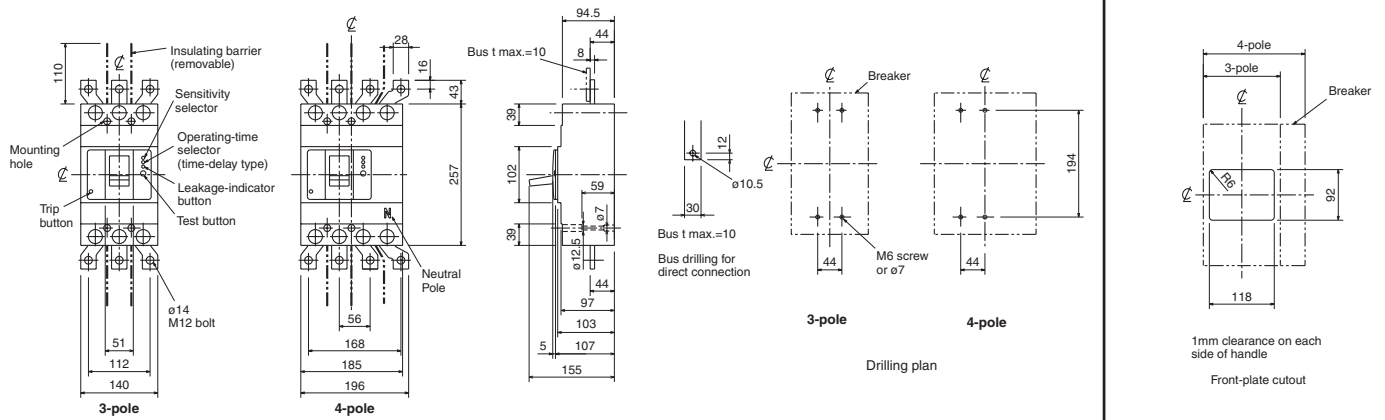

Rear connection

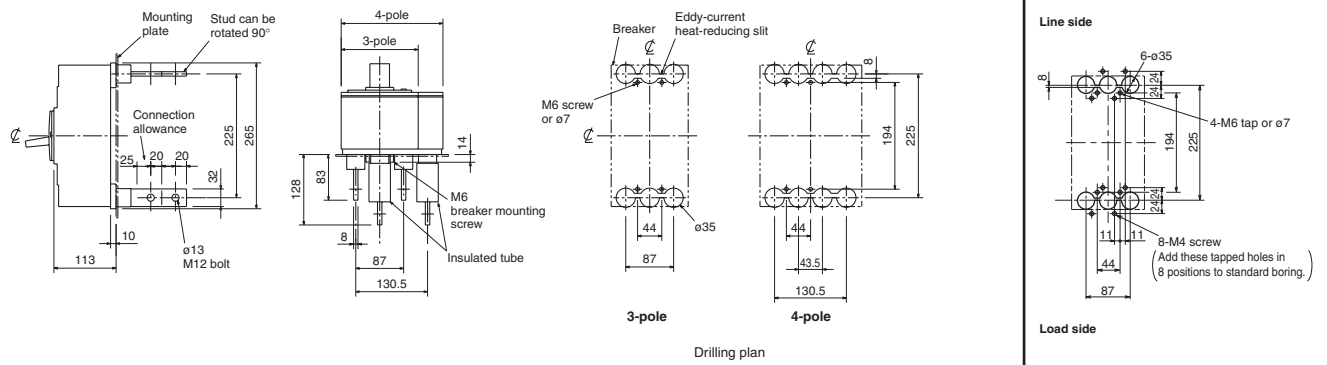

Boring dimensions for rear connection type barriers (3-pole)

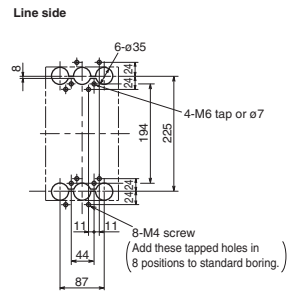

Load side

Note: The bore dimensional drawing shows the breaker viewed from the rear.

6. Characteristics and Dimensions

Earth-Leakage Circuit Breakers for CE Marking

NV630-SEW NV630-HEW



Type NV630-SEW

Type name		NV630-SEW	NV630-HEW	
Number of poles		3	4	
Rated operational voltage Ue (V AC) (#1)		100-440 Multi-voltage type		
Rated current In (Amp.)		300-630 adjustable		
High-speed type	Rated current sensitivity IΔn (mA)	100 · 200 · 500 Selectable		
	Max. operating time at 5IΔn (s)	0.04		
Time-delay type	Rated current sensitivity IΔn (mA)	(100 · 200 · 500 Selectable)		
	Max. operating time at 5IΔn (s)	(0.45 · 1.0 · 2.0 Selectable)		
	Max. inertial non-operating time at 2IΔn (s)	(0.1 · 0.5 · 1.0)		
Earth-leakage indication system		Button		
Rated short-circuit breaking capacity (kA) IEC 60947-2 (Icu/Ics) EN 60947-2	AC	440V	42/42	65/65
		400V	50/50	70/70
		230V	85/85	100/100
Standard Attached Parts (Front connection)		Mounting screw: M6×72 (4pcs) Insulation barrier: (3P: 4pcs, 4P: 6pcs)		

Note (#1) Rated operational voltage of time-delay type is for 200-440V.

Operating Characteristics

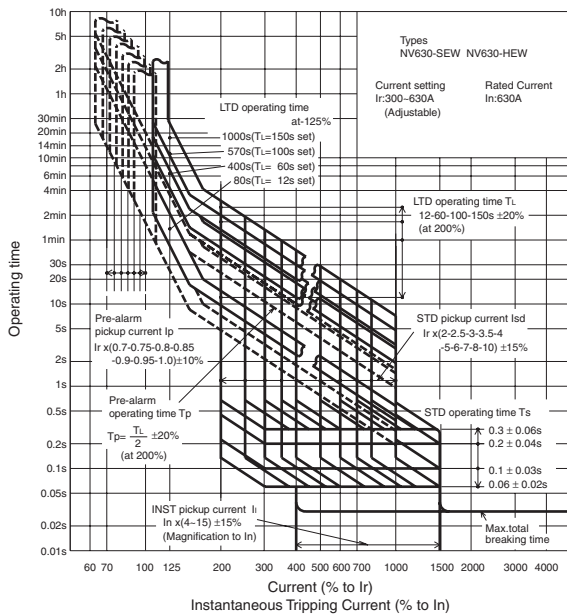

Earth-Leakage Tripping Characteristics

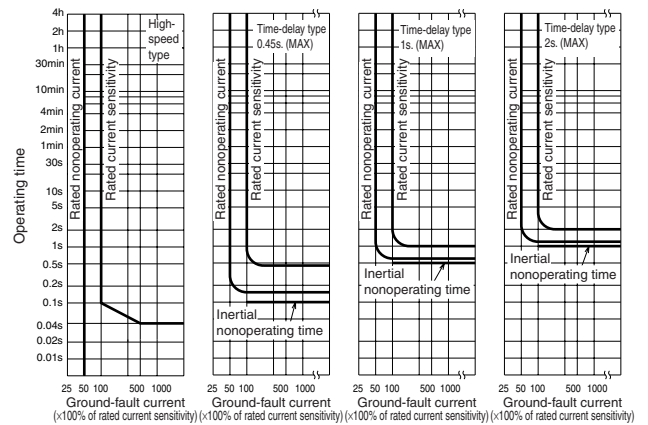

Internal Accessories

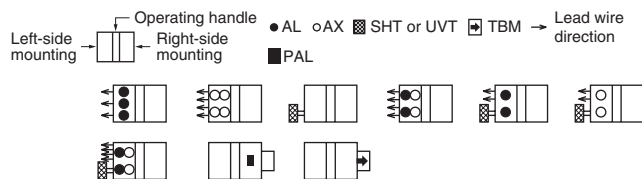

Remark 1. Instead of TBM, pre-alarm module (PAL) can be attached.
2. Refer to page 53.

External Accessories

(An order for ☆ should be placed at the same time as an order of circuit breaker main body.)

Accessories	Type name	Reference page	Accessories	Type name	Reference page
Operating handle	F F-4S	62	Terminal cover	Large (TC-L) TCL-4SW3 (*1)(*2)	70
	V V-4S	65	Skeleton (TTC) TTC-4SW3 (*2)		
	S S4SW	68	Rear (BTC) BTC-4SW3 (*1)(*2)		
Mechanical interlock (MI)	MI-4SW3 (*1)	79	Handle lock device	HL HL-4SW	80
Auxiliary handle (HT)	HT-4SW	80		HL-S HLS-4SW	
			Electrical operation device	☆	71

Note (#1) This is for NV630-SEW
(#2) The designation depends on the number of poles. Refer to the reference page.

Current reducing curve

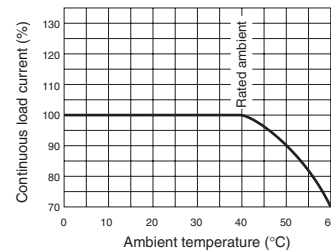

Internal Wiring Diagram

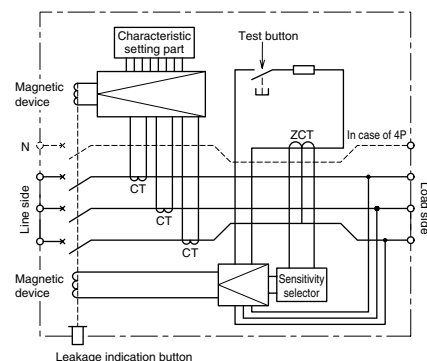

Front connection

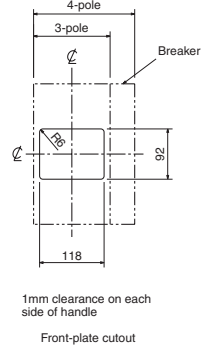
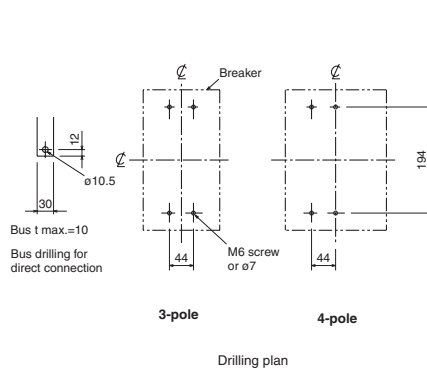
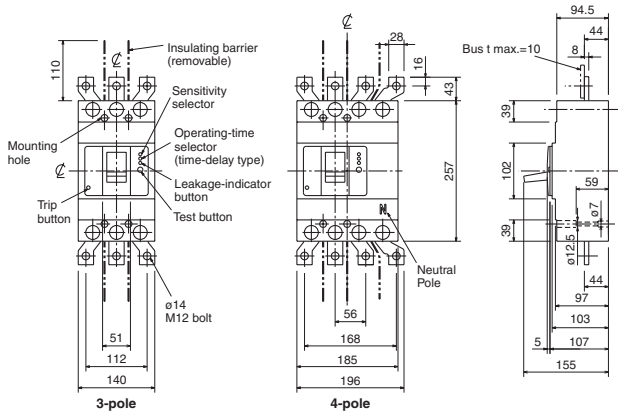

Rear connection

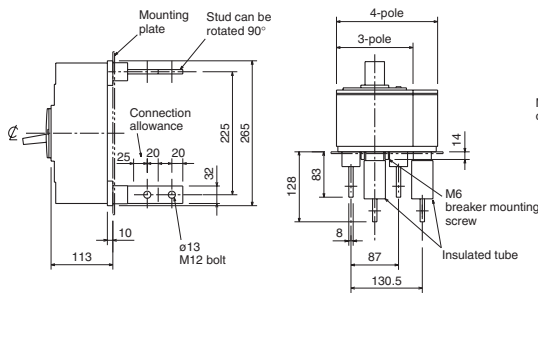

Boring dimensions for rear connection type barriers (3-pole)

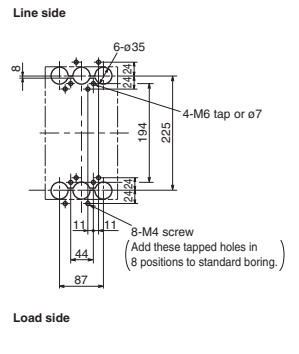

Note: The bore dimensional drawing shows the breaker viewed from the rear.

6. Characteristics and Dimensions

Earth-Leakage Circuit Breakers for CE Marking

NV800-SEW
NV800-HEW



Type NV800-SEW

Type name		NV800-SEW	NV800-HEW
Number of poles		3	
Rated operational voltage Ue (V AC)		100-440 Multi-voltage type	
Rated current In (Amp.)		400-800 adjustable	
High-speed type	Rated current sensitivity IΔn (mA)	(100 · 200 · 500 Selectable)	
	Max. operating time at 5IΔn (s)	(0.04)	
Time-delay type	Rated current sensitivity IΔn (mA)	100 · 200 · 500 Selectable	
	Max. operating time at 5IΔn (s)	0.45 · 1.0 · 2.0 Selectable	
	Max. inertial non-operating time at 2IΔn (s)	0.1 · 0.5 · 1.0	
Earth-leakage indication system		Button	
Rated short-circuit breaking capacity (kA) IEC 60947-2 (Icu/Ics) EN 60947-2	AC	440V	42/42
		400V	50/50
		230V	85/85
Standard Attached Parts (Front connection)		Mounting screw: M6×35 (4pcs) Insulation barrier: (2pcs)	

Operating Characteristics

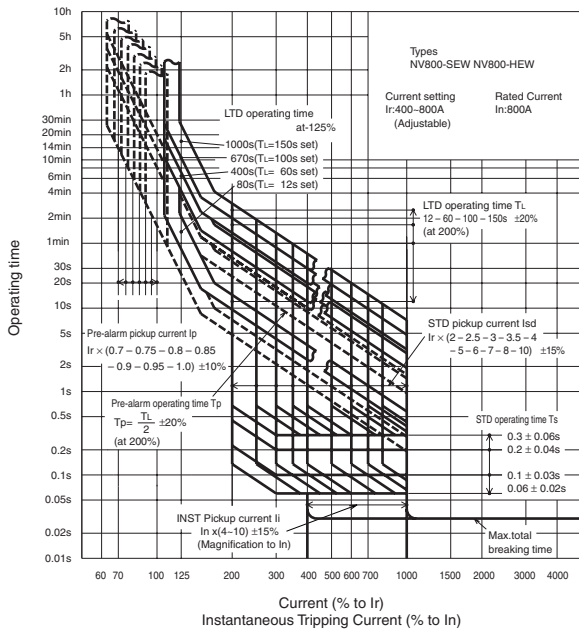

Earth-Leakage Tripping Characteristics

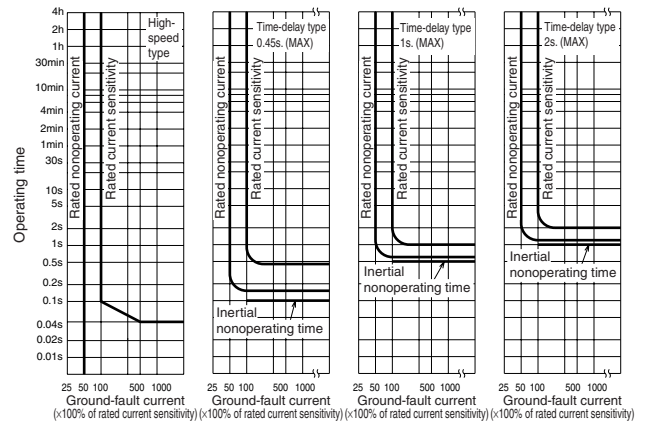

Internal Accessories

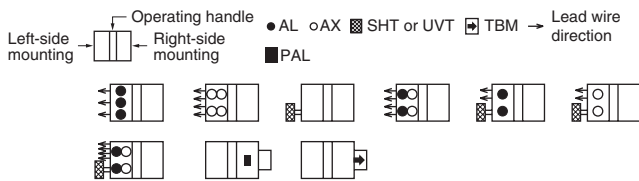

Remark: 1. Instead of TBM, pre-alarm module (PAL) or trip indicator (TI) can be attached.
2. Refer to page 53.

External Accessories

(An order for ☆ should be placed at the same time as an order of circuit breaker main body.)

Accessories	Type name	Reference page	Accessories	Type name	Reference page
Operating handle	F F-8S	62	Terminal cover	Large (TC-L) TCL-8SW3	70
	V V-8S	65		Skeleton (TTC) TTC-8SW3	
	S S4SW	68		Rear (BTC) BTC-8SW3	
Mechanical interlock (MI)	MI-8SW3	79	Handle lock device	HL HL-4SW	80
Auxiliary handle (HT)	HT-4SW	80		HL-S HLS-8SW	
			Electrical operation device	☆	71

Current reducing curve

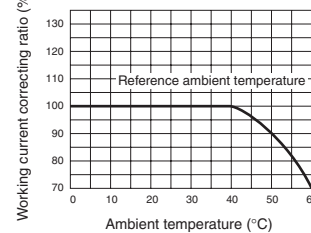

Internal Wiring Diagram

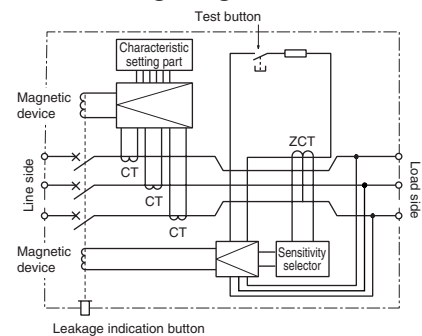

Front connection

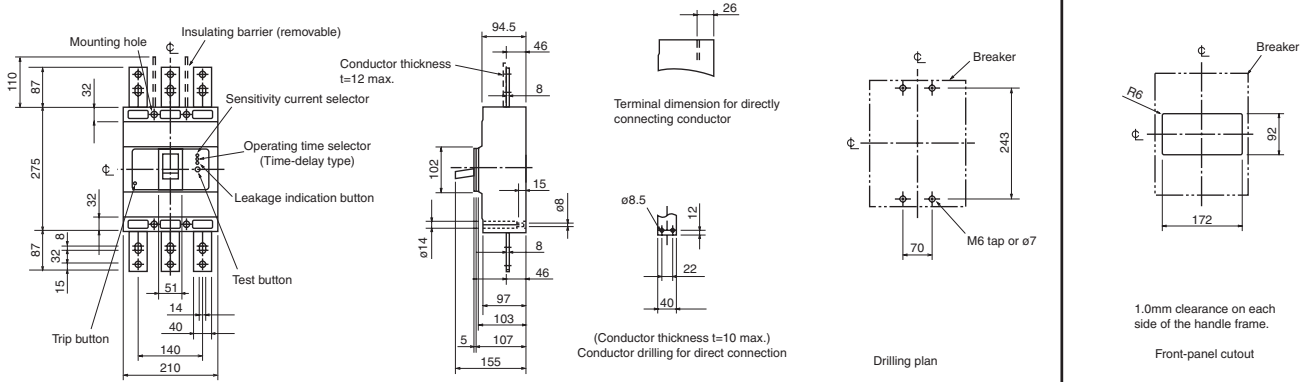

Rear connection

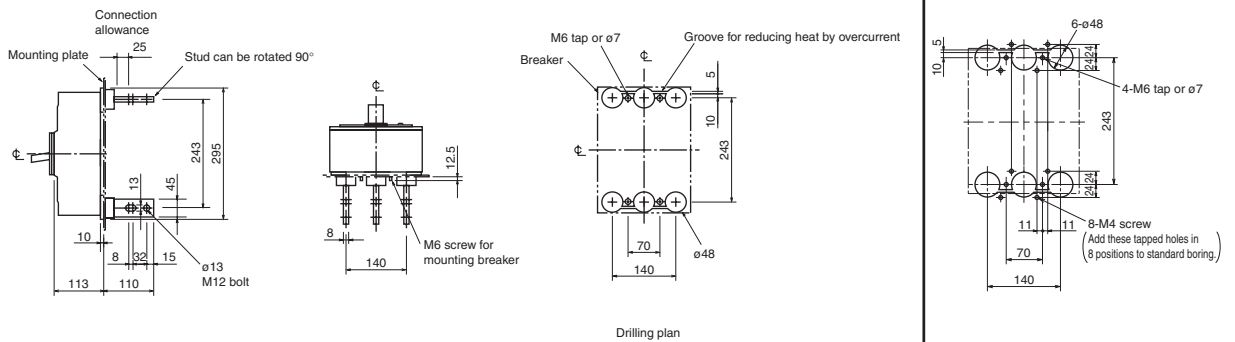

Note: The bore dimensional drawing shows the breaker viewed from the rear.

6. Characteristics and Dimensions

UL489 Listed Molded-Case Circuit Breakers

NF50-SWU



Type NF50-SWU

Type name		NF50-SWU		
Rated current In (Amp.)		(3) 5 10 15 20 30 40 50		
Number of poles		2	3	
Rated short-circuit breaking capacity (kA)	UL489	Rated voltage (AC V)		
		AC	240V	
	IEC 60947-2 (Icu/Ics)	Rated insulation voltage Ui (V)		
		AC	500V	7.5/4
			440V	7.5/4
400V	7.5/4			
230V	15/8			
Standard attached parts		Mounting screw: M4×0.7×55 (2pcs) Insulation barrier: (2P: 2pcs, 3P: 4pcs)		

Operating Characteristics

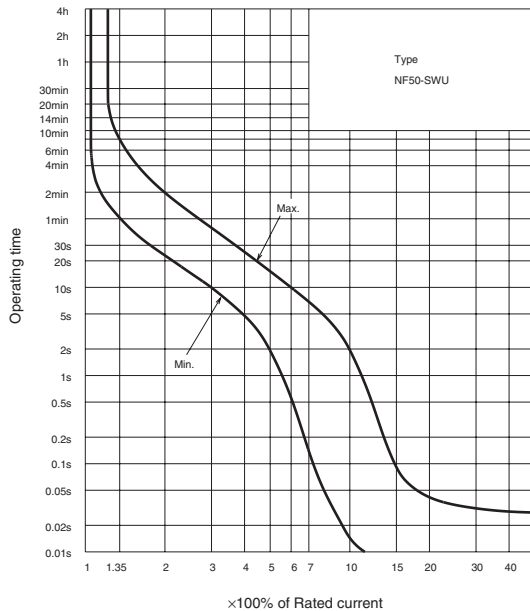

Internal Accessories

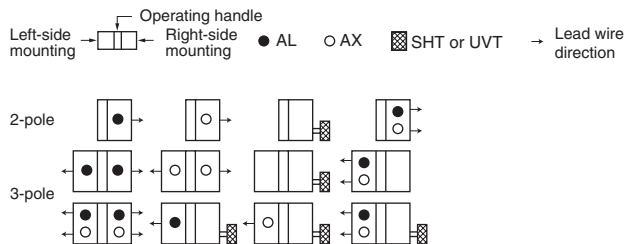

Remark: 1. Refer to page 54.

Temperature Characteristics

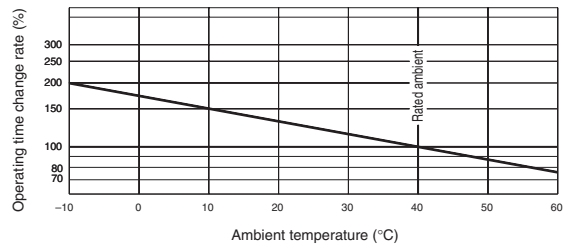

External Accessories

Accessories	Type name	Accessories	Type name	
Operating handle	F	F-05SUL2 F-05SUL	Mechanical interlock	
	V	V-05SUL2 V-05SUL		MI
	S	S05SWU	MI	MI-05SWU3
Handle lock device	HL	HLF-05SWU	Terminal cover	Large

Front connection

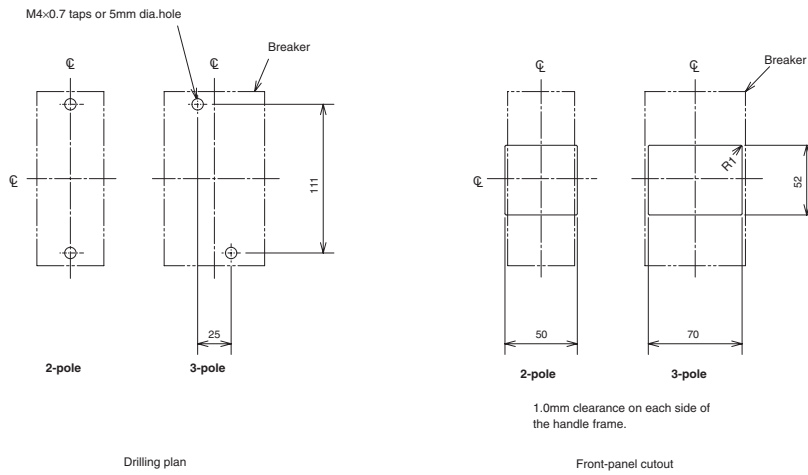
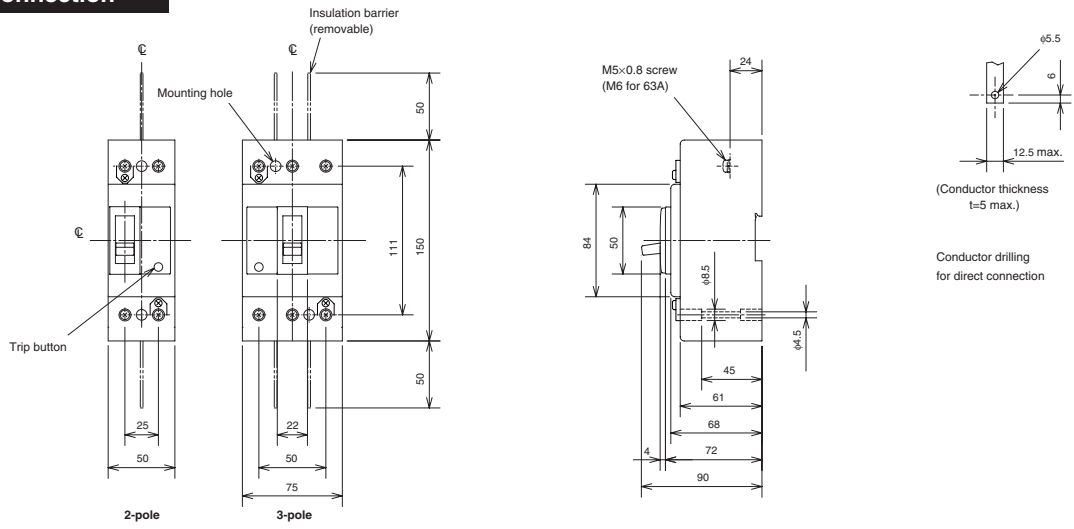

6. Characteristics and Dimensions

UL489 Listed Molded-Case Circuit Breakers

NF100-CWU NF100-SWU



Type NF100-SWU

Type name		NF100-CWU	NF100-SWU		
Rated current I _n (Amp.) at ambient temperature 40°C (IEC30°C)		50 60 75 100	15 20 30 40 50 60 75 100		
Number of poles		2	3	2 3	
Rated short-circuit breaking capacities (kA)	UL 489	Rated voltage (AC V)		240	480Y/277
		AC	480Y/277V	—	22
	240V		10	35	
	IEC 60947-2 (Icu/Ics)	Rated insulation voltage U _i (V)		600	690
		AC	690V	—	8/4
			500V	7.5/4	18/9
440V			10/5	25/13	
400V			10/5	30/15	
DC	230V	30/15	50/25		
	250V	7.5/4	15/8		
Standard attached parts		Mounting screw: M4×0.7×55 (2pcs) Insulation barrier: (2P: 2pcs, 3P: 4pcs), Insulation board: (1pc)			

Operating Characteristics

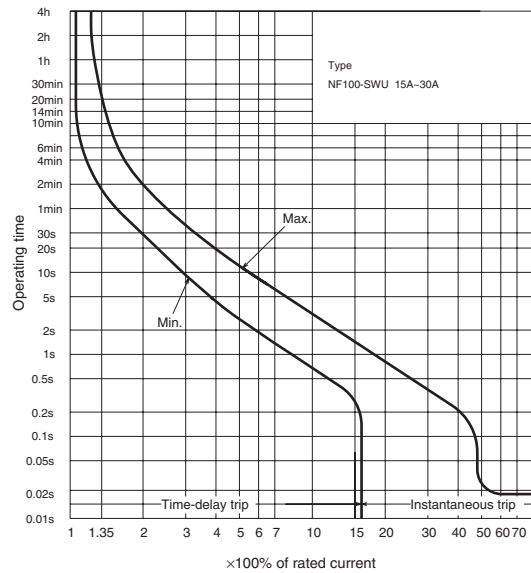
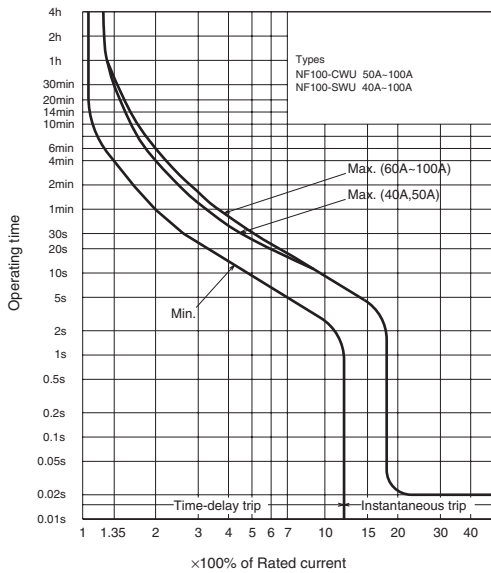

Internal Accessories

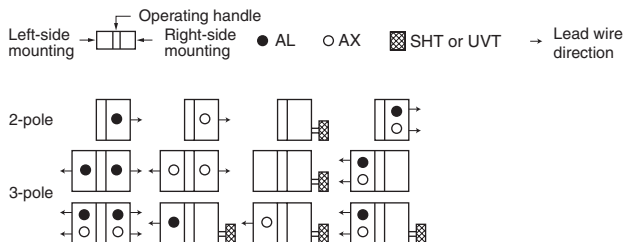

Remark: 1. Refer to page 54.

Ambient Compensating Curve

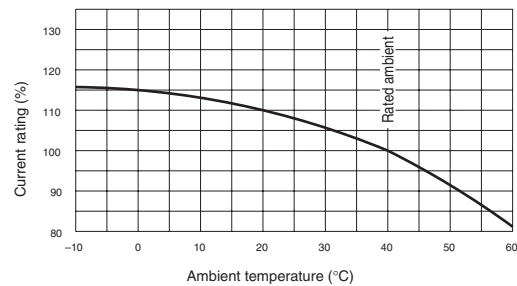

External Accessories

Accessories	Type name	Accessories	Type name
Operating handle	F F-1SUL2 F-1SUL	Mechanical interlock	MI MI-05SWU3
	V V-1SUL2 V-1SUL		Terminal cover Large
	S S1SWU		
Handle lock device	HL HLF-1SWU		

Front connection

(Standard)

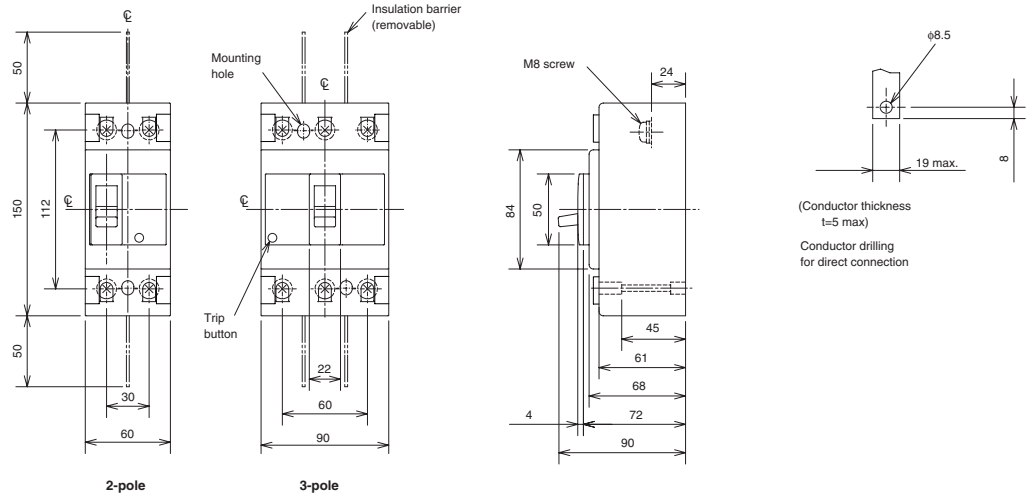

Front connection (Solderless terminal)

(Option)

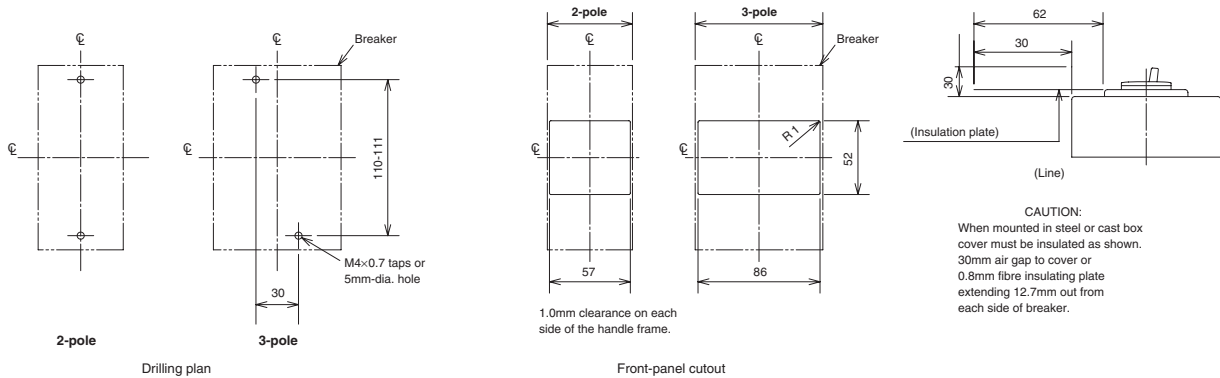
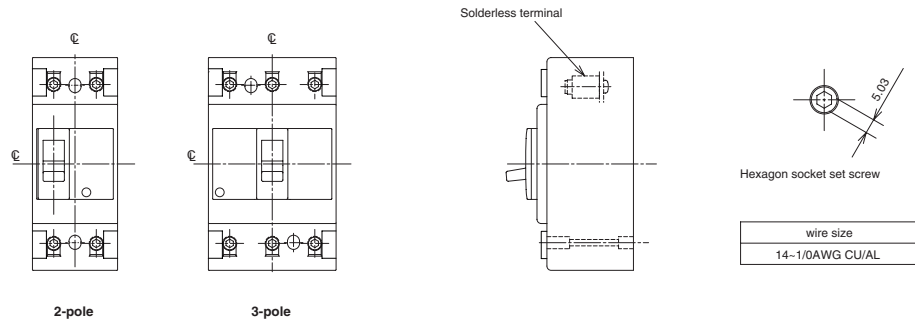

6. Characteristics and Dimensions

UL489 Listed Molded-Case Circuit Breakers

NF225-CWU



Type NF225-CWU

Type name		NF225-CWU		
Rated current In (Amp.) at ambient temperature 40°C (IEC30°C)		125 150 175 200 225		
Number of poles		3		
Rated short-circuit breaking capacities (kA)	UL 489	Rated voltage (AC V)		
		AC	240V	
	IEC 60947-2 (Icu/Ics)	Rated insulation voltage Ui (V)		
		AC	500V	10/5
			440V	15/8
			400V	18/9
DC	250V	35/18		
Standard attached parts		Mounting screw: M4×0.7×55 (2pcs) Insulation barrier: (4pcs), Terminal cover: (1 set), (*2)		

Note (*1) Use either two poles. When wired as shown at the bottom of page 26, the models can be used for up to 400 V DC.

(*2) The standard configuration contains a protection cover and adopts the IP20 (finger protection) structure.

Operating Characteristics

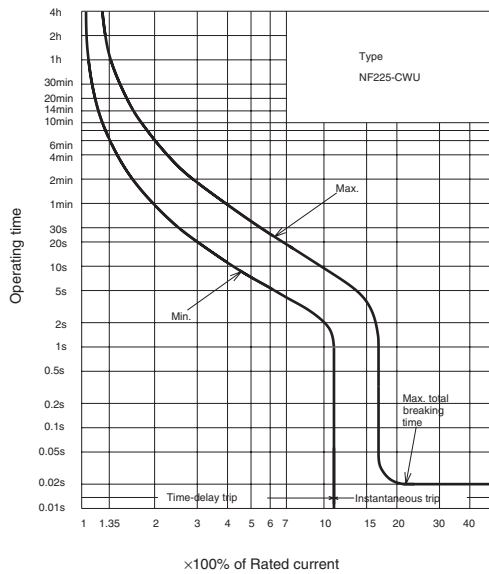

Internal Accessories

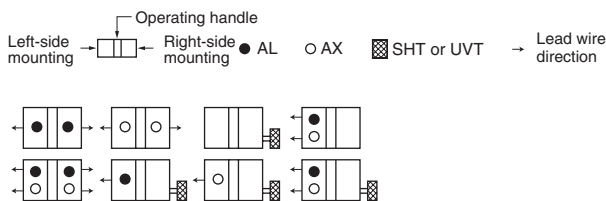

Remark: 1. Refer to page 54.

Ambient Compensating Curve

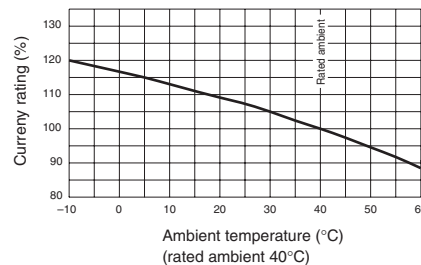

External Accessories

Accessories	Type name	Accessories	Type name
Operating handle	F F-2SUL	Mechanical interlock	MI MI-05SWU3
	V V-2SUL		Terminal cover
	S S2SWU		
Handle lock device	HL HLF-2SWU		

Front connection

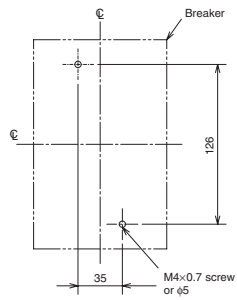
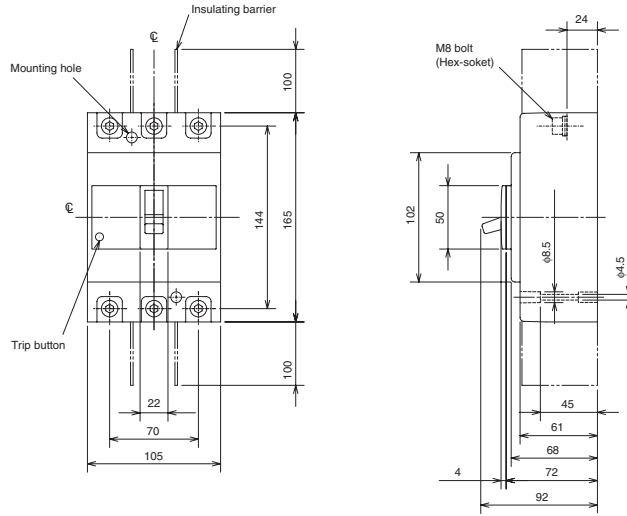

Drilling plan

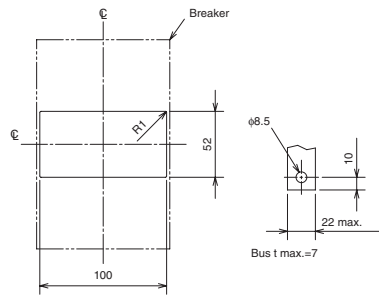

Front cover cutout
1mm clearance on
each side of handle

Bus drilling for
direct connection

6. Characteristics and Dimensions

UL489 Listed Molded-Case Circuit Breakers

NF-SFW
NF-SJW
NF-HJW



Type NF-SFW

Type name		NF-SFW	NF-SJW	NF-HJW			
Rated current I _n (Amp.) at ambient temperature 40°C (IEC30°C)		15 20 30 40 50 60 70 80 90 100 110 125 150	(125) (150) 175 200 225 250	125 150 175 200 225 250			
Number of poles		3	3	3			
Rated short-circuit breaking capacities (kA)	UL 489	Rated voltage (AC V)		600Y/347			
		AC	600Y/347V	14	14	18	
			480V	35	35	50	
	IEC 60947-2 (Icu/Ics)	AC	240V	65	65	100	
			Rated insulation voltage U _i (V)		690	690	690
			AC	690V	8/8	8/8	15/15
				500V	30/30	30/30	36/36
				440V	36/36	36/36	50/50
				400V	36/36	36/36	50/50
				230V	85/85	85/85	100/100
DC	250V (*1)	20/20	20/20	20/20			
Standard attached parts		Mounting screw: M4×0.7×73 (4pcs) Insulation barrier: (4pcs), Insulation board: (1pc)					

Note (*1) Use either two poles. When wired as shown at the bottom of page 26, the models can be used for up to 500 V DC.

Operating Characteristics

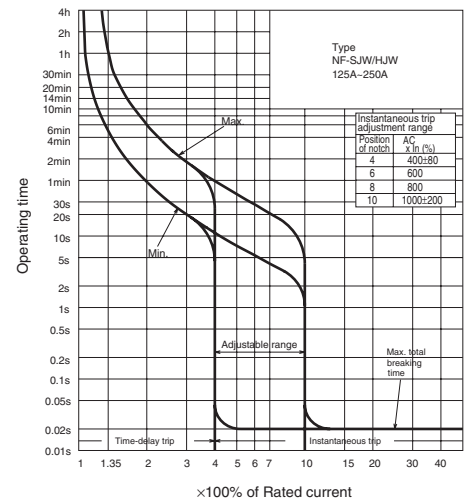
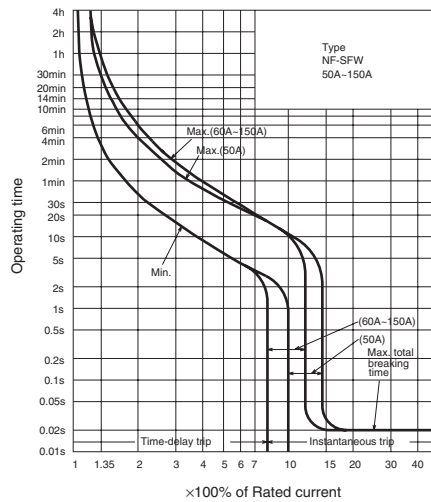
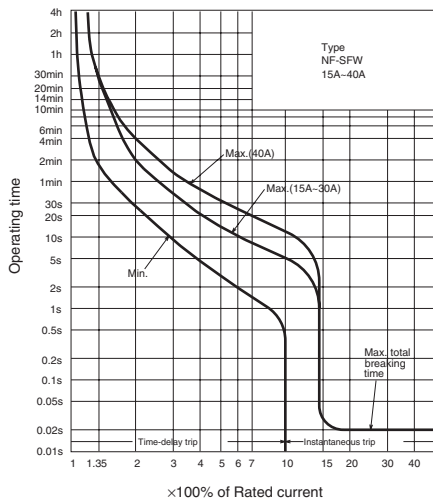

Internal Accessories

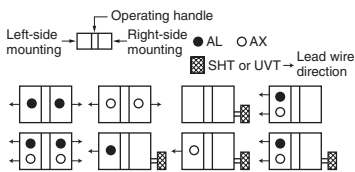

Remark: 1. Refer to page 54.

Ambient Compensating Curve

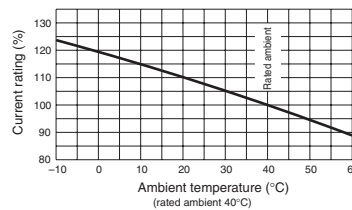

Remark: 1. The reference ambient temperature for IEC models is 30°C.

External Accessories

Accessories	Type name	Accessories	Type name		
Operating handle	F	F-2SGUL	Mechanical interlock		
	V	V-2SGUL		MI	MI-05SWU3
	S	S2GSWU		Terminal cover	Large
Handle lock device	HL	HLF-2GSWU			

Front connection

(Standard)

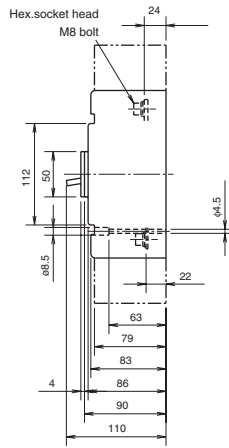
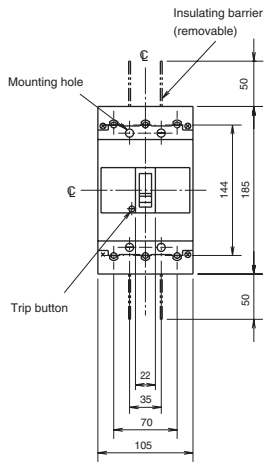

CAUTION:
Insulating barriers must be used with uninsulated bus bars or clamp on terminals.

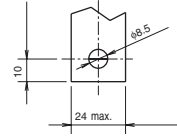

(Conductor thickness t=7max.)

Bus bar drilling for direct connection

4-FRONT

Front connection (Solderless terminal)

(Option)

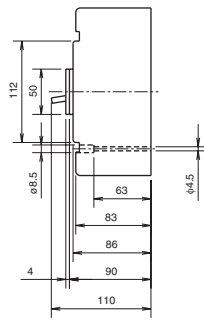
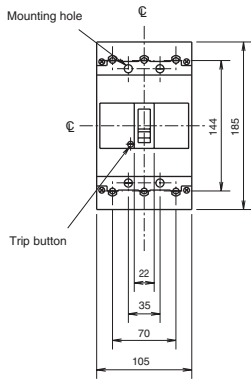

Hexagon socket set screw



Wire size
14AWG-250MCM CU/AL

3-FRONT

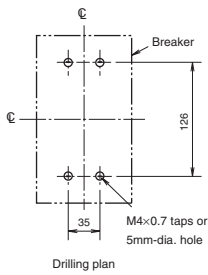

Drilling plan

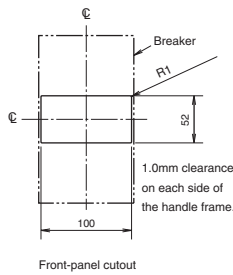

Front-panel cutout

CAUTION:
When mounted in steel or cast box cover must be insulated as shown.
26mm air gap to cover or extending 12.7mm out from each side of breaker.

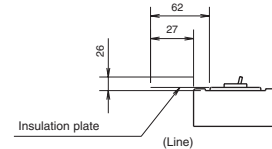

5-RIGHT

Outline and dimensions (mm (inch))
Type NF-SFW,NF-SJW,NF-HJW

6. Characteristics and Dimensions

UL489 Listed Molded-Case Circuit Breakers

NF-SKW



Type NF-SKW

Type name		NF-SKW		
Rated current In (Amp.) at ambient temperature 40°C		250 300	350 400	
Number of poles		3		
Rated short-circuit breaking capacities (kA)	UL 489	Rated voltage (AC V)		
		AC	600Y/347V	20
			480V	35
	240V	65		
	IEC 60947-2 (Icu/Ics)	Rated insulation voltage Ui (V)		690
		AC	690V	10/10 (5/5) (*1)
500V			30/30 (25/25) (*1)	
440V			42/42 (36/36) (*1)	
400V	45/45 (36/36) (*1)			
230V	85/85 (65/65) (*1)			

Note (*1) In case of solderless terminal, interrupting capacity reduces: (/).

Operating Characteristics

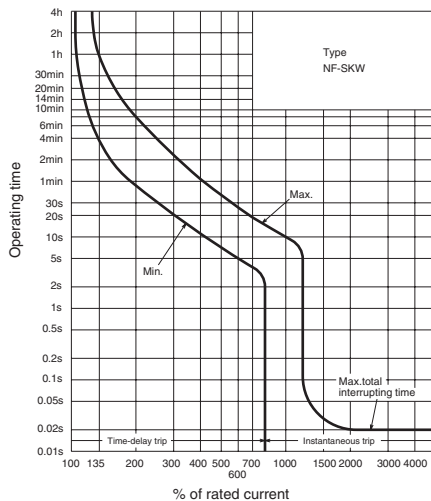

Internal Accessories

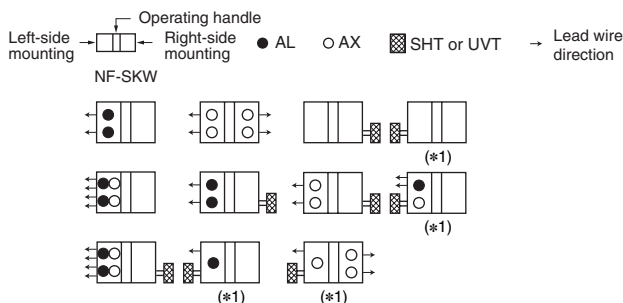

Note (*1) Right-side mounting is standard of SHT and UVT. Specify separately for left-side mounting.

Remark: 1. Refer to page 54.

Ambient Compensating Curve

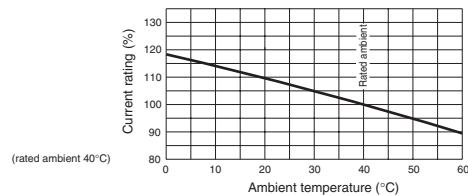

External Accessories

Accessories	Type name	Accessories	Type name
Operating handle	F F-4SUL	Terminal cover	Large TC-L
	V V-4SUL		
	S S4SKW	TCL-4SKW	
Handle lock device	HL HL-4SP		

Front connection (Solderless terminal)

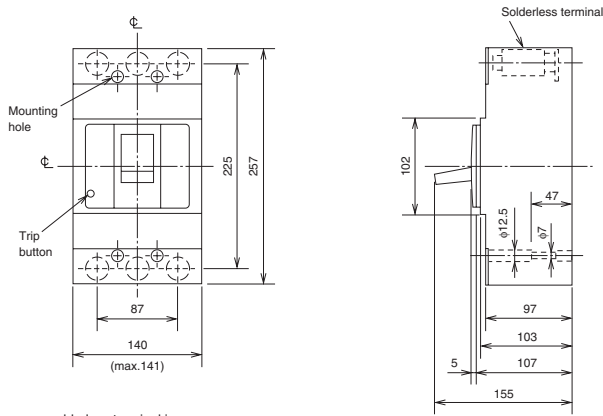

Note: Do not remove solderless terminal in any case.
Standard attached parts
Mounting screw:M6x60 (4pcs), Insulating plate: (1pc)

Hexagon socket set screw

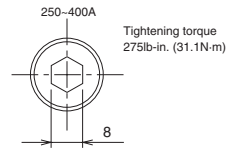

UL

Ampere ratings	Wire size
250A, 300A	250-350MCM CU
250A	350MCM AL
350A, 400A	3/0AWG CU ONLY

IEC

Ampere ratings	Wire size (IEC 60228)	
	Class 2	Class 5
250A-350A	70-185mm ²	95-185mm ²
400A	150-240mm ²	150-185mm ²

Front connection (Busbar terminal)

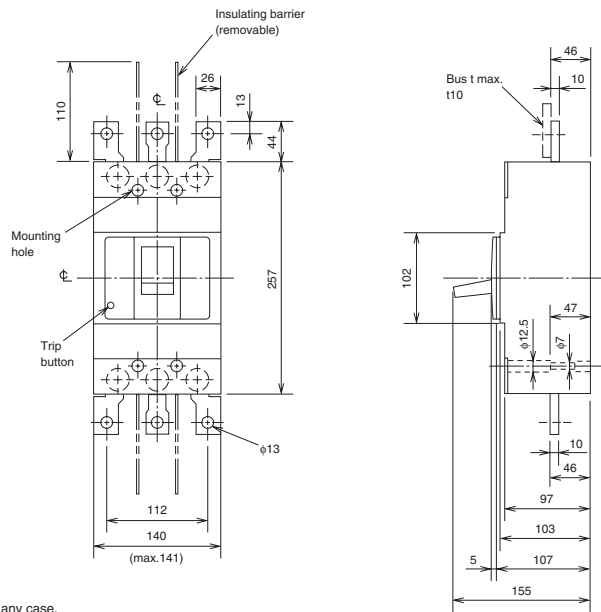

Note: Do not remove busbar terminal in any case.
Standard attached parts
Mounting screw:M6x60 (4pcs), Insulating barrier: (4pcs), Insulating plate: (1pc)

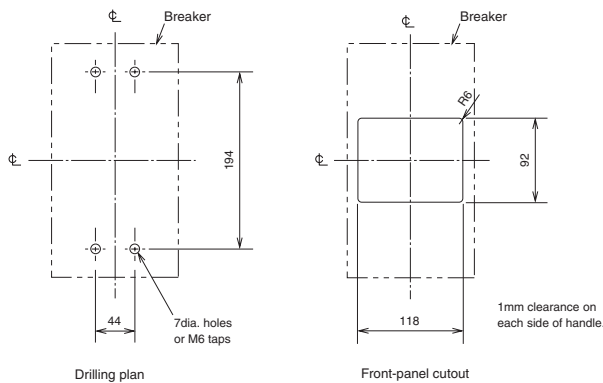

CAUTION

When mounted in steel or cast box cover must be insulated as shown.
58mm air gap to cover or 0.8mm fibre insulating plate extending 12.7mm out from each side of breaker.

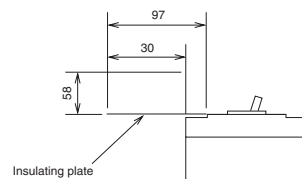

(Line)

6. Characteristics and Dimensions

UL489 Listed Molded-Case Circuit Breakers

NF-SLW



Type NF-SLW

Type name		NF-SLW		
Rated current In (Amp.) at ambient temperature 40°C		500 600		
Number of poles		3		
Rated short-circuit breaking capacities (kA)	UL 489	Rated voltage (AC V)		
		AC	600Y/347V	20
			480V	35
	240V	85		
	IEC 60947-2 (Icu/Ics)	Rated insulation voltage Ui (V)		690
		AC	690V	10/10
500V			30/30	
440V			42/42	
400V	45/45			
230V	85/85			

Operating Characteristics

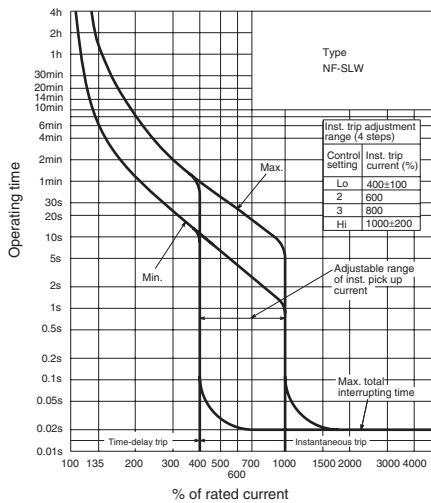

Internal Accessories

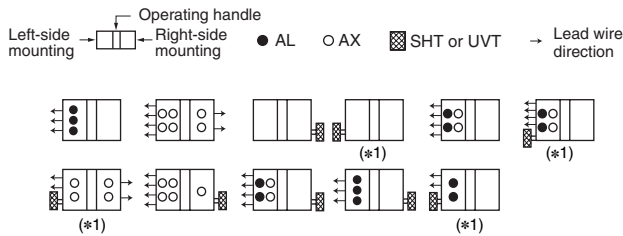

Note (*1) Right-side mounting is standard of SHT and UVT. Specify separately for left-side mounting.

Remark: 1. Refer to page 54.

Ambient Compensating Curve

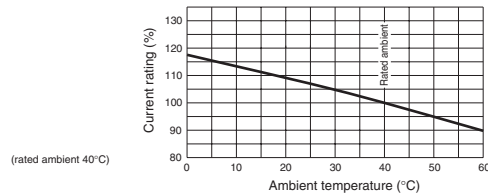

External Accessories

Accessories	Type name	Accessories	Type name
Operating handle	F F-6SUL	Terminal cover	Large TC-L TCL-6SLW
	V V-6SUL		
	S S4SKW		
Handle lock device	HL HL-4SP		

Front connection (Solderless terminal)

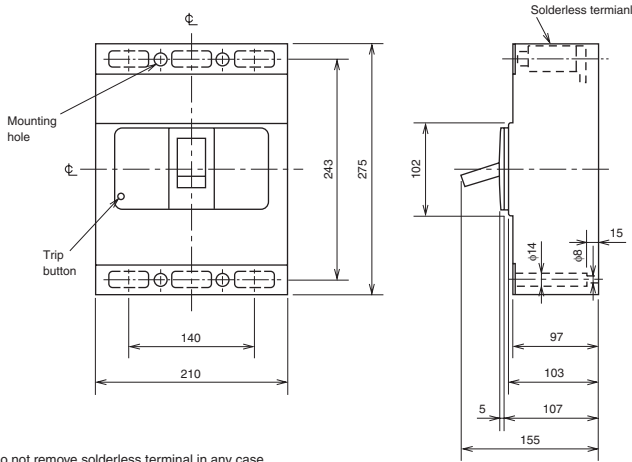

Hexagon socket set screw

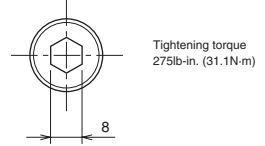

UL

Amperage ratings	Wire size
500A, 600A	250-500MCM CU ONLY

IEC

Amperage ratings	Wire size (IEC 60228)	
	Class 2	Class 5
500A, 600A	95-185mm ²	120-185mm ²

Note: Do not remove solderless terminal in any case.
Standard attached parts
Mounting screw:M6×35 (4pcs), Insulating plate: (1pc)

Front connection (Busbar terminal)

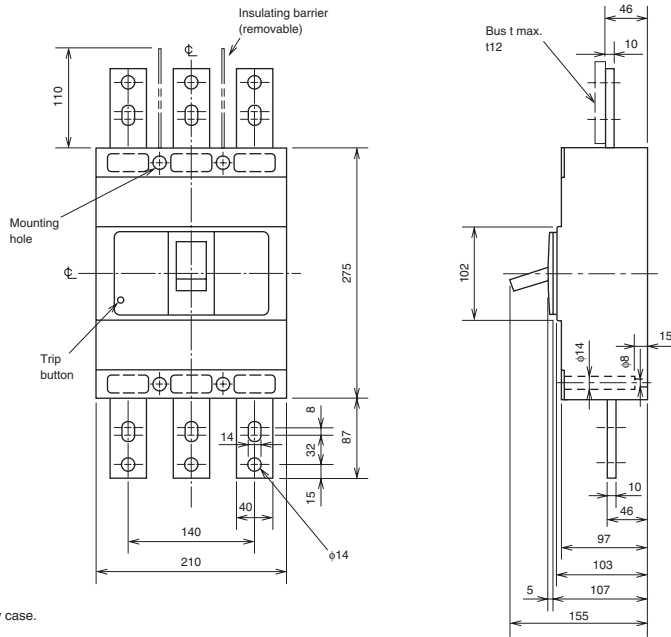

Note: Do not remove busbar terminal in any case.
Standard attached parts
Mounting screw:M6×35 (4pcs), Insulating barrier: (2pcs), Insulating plate: (1pc)

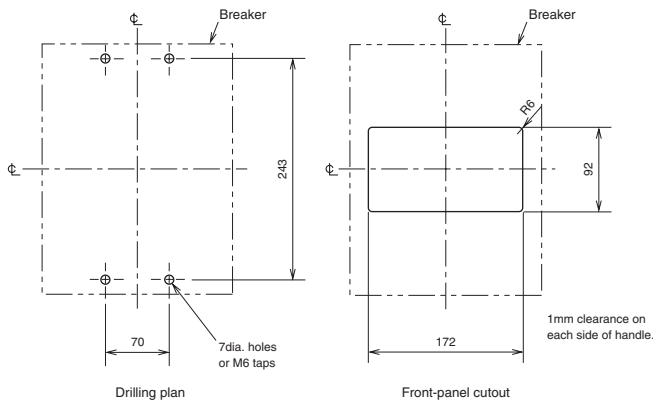

CAUTION

When mounted in steel or cast box cover must be insulated as shown.
58mm air gap to cover or 0.8mm fibre insulating plate extending 12.7mm out from each side of breaker.

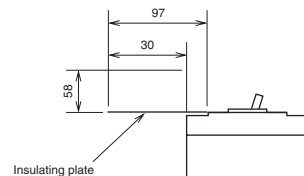

(Line)

6. Characteristics and Dimensions

Miniature Circuit Breakers

BH
BH-P



Type BH



Type BH-P

Type		BH			BH-P		
Number of poles		1	2	3	1	2	3
Rated current (A) at ambient temperature 40°C		70	70, 100	70, 100	70	70, 100	70, 100
Rated voltage (V)		AC			230/400		
		DC			125		
Breaking capacity (kA) sym.	IEC 60898	AC230/400V	3	—	3	—	—
	—	AC400V	—	3	—	—	3
	—	DC125V	1			1	

Operating Characteristics

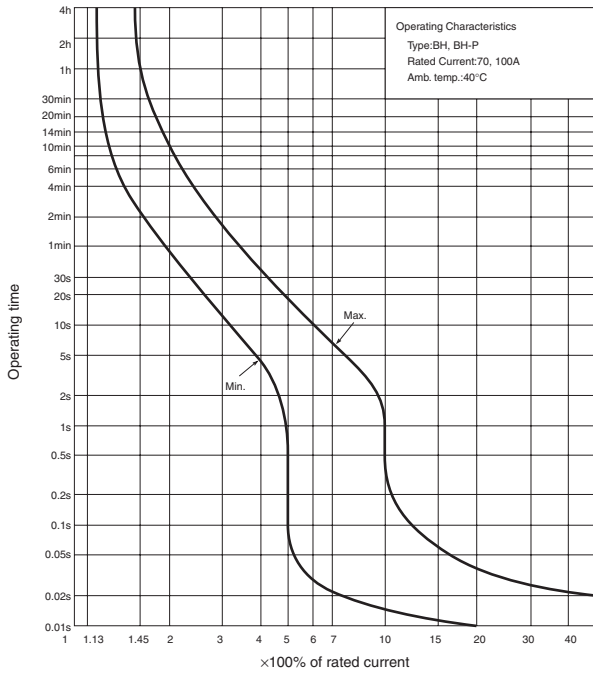

Ambient Compensating Curve

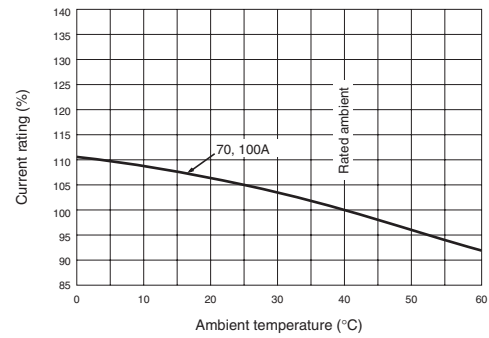

Outside Dimension Diagram

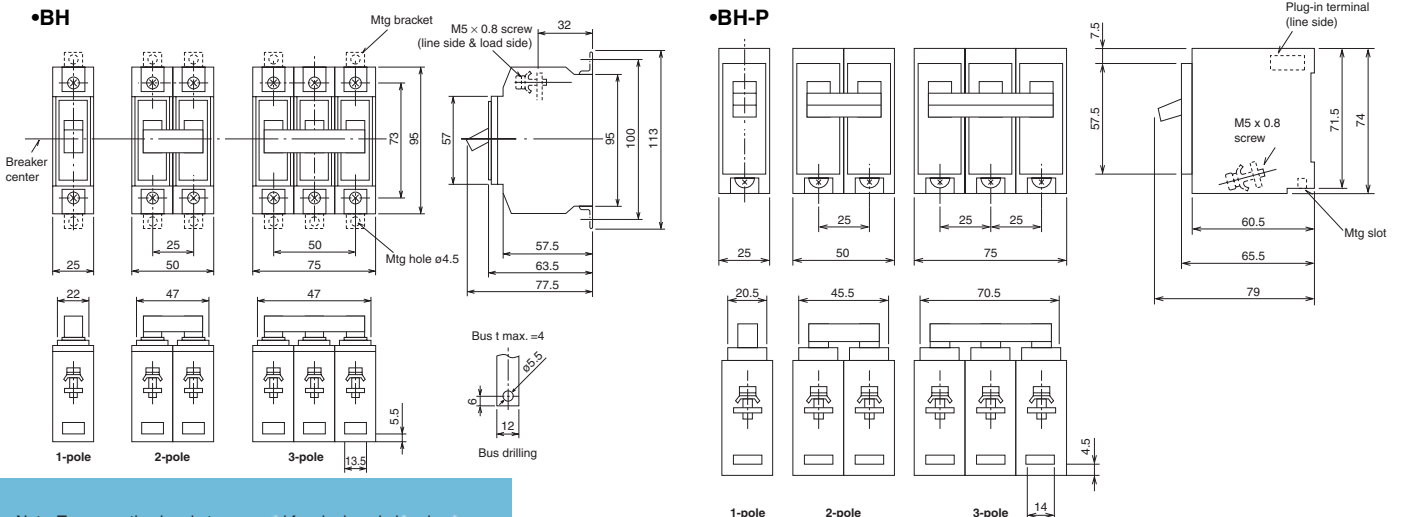

Note: Two mounting brackets are used for single-pole breakers, and four for two-pole and three-pole breakers.

BH-S



Type BH-S

Type		BH-S M3			BH-S M6		
Number of poles		1	2	3	1	2	3
Rated current (A) at ambient temperature 40°C		5, 10, 15, 20, (25), 30, 40, 50, 60	10, 15, 20, (25), 30, 40, 50, 60	15, 20, (25), 30, 40, 50, 60	5, 10, 15, 20, (25), 30, 40, 50, 60	10, 15, 20, (25), 30, 40, 50, 60	15, 20, (25), 30, 40, 50, 60
Rated voltage (V)		AC	230/400	400	230/400	400	400
		DC	—	125	—	125	—
Breaking capacity (kA) sym.		IEC 60898	AC230/400V	3	—	6	—
			AC400V	—	3	—	6
		—	DC125V	—	1	—	1

Operating Characteristics

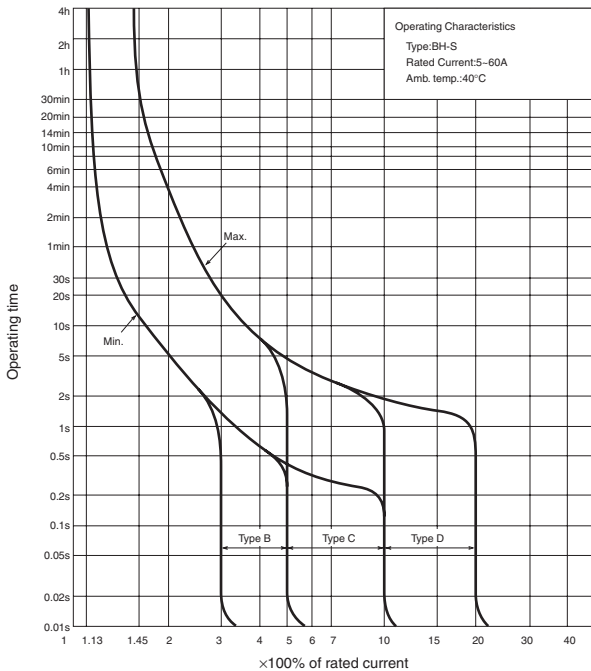

Ambient Compensating Curve

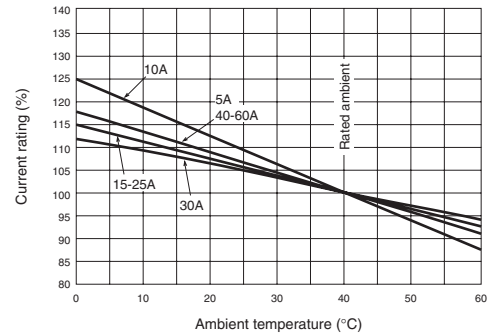

Outside Dimension Diagram

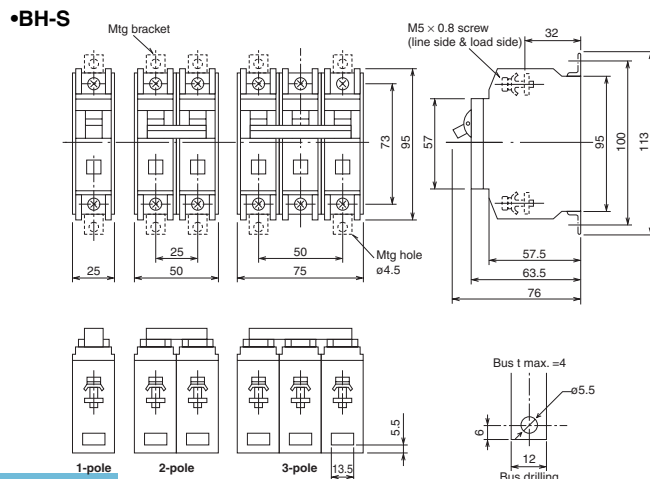

Note: Two mounting brackets are used for single-pole breakers, and four for two-pole and three-pole breakers.

6. Characteristics and Dimensions

Miniature Circuit Breakers

BH-PS



Type BH-PS

Type		BH-PS M3			BH-PS M9		
Number of poles		1	2	3	1	2	3
Rated current (A) at ambient temperature 40°C		10, 15, 20, 30, 40, 50, 60	10, 15, 20, 30, 40, 50, 60	15, 20, 30, 40, 50, 60	6, 10, 16, 20, (25), 32, 40, 50, 60	10, 16, 20, (25), 30, 40, 50, 60	10, 16, 20, (25), 32, 40, 50, 60
Rated voltage (V)		AC	230/400	400	400	230/400	400
		DC	—	125	—	—	—
Breaking capacity (kA) sym.	IEC 60898	AC230/400V	3	—	9	—	—
	—	AC400V	—	3	—	—	9
	—	DC125V	—	1	—	—	—

Operating Characteristics

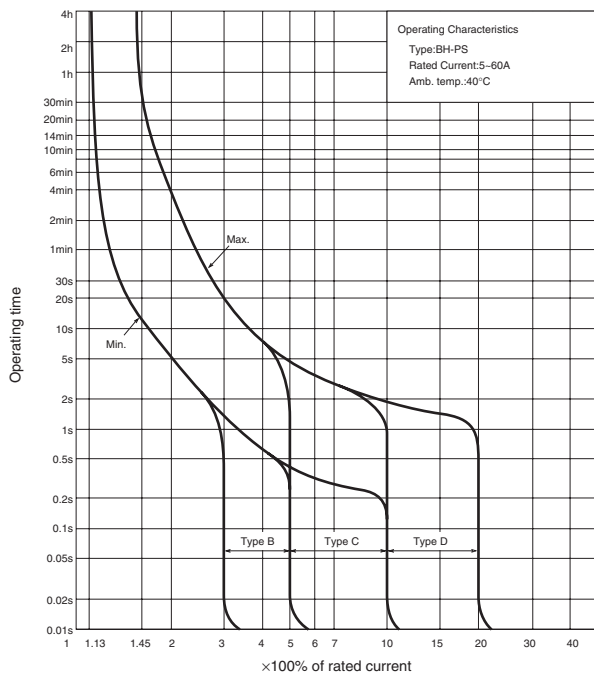

Ambient Compensating Curve

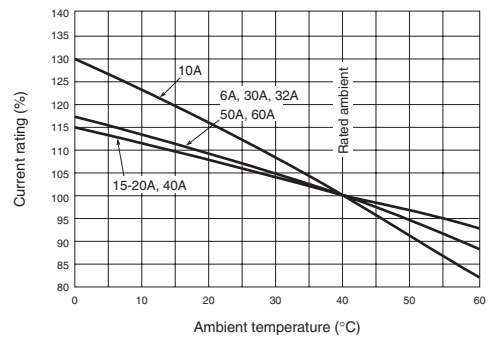

Outside Dimension Diagram

•BH-PS

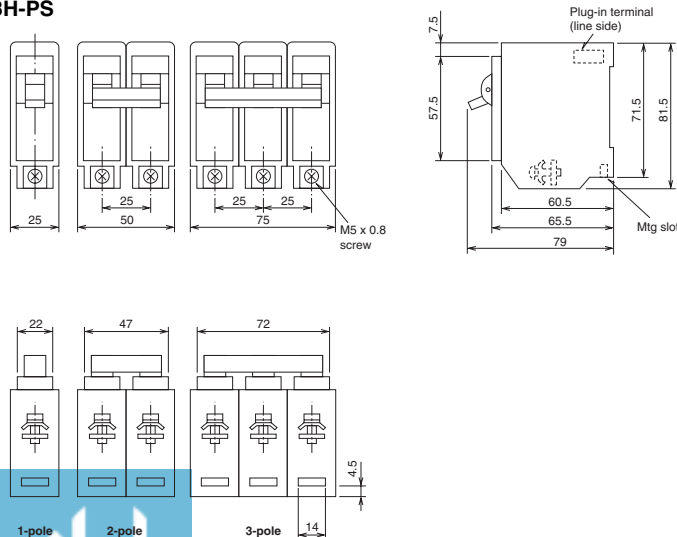

6. Characteristics and Dimensions

DIN Series

BH-D6



Type BH-D6

MCB	BH-D6 (IEC 60898)				
Number of poles	1	2	3	4 (3+N)	2 (1+N)
Rated current (A) at ambient temperature 30°C	6, 10, 13, 16, 20, 25, 32, 40, 50, 63	6, 10, 13, 16, 20, 25, 32, 40, 50, 63	6, 10, 13, 16, 20, 25, 32, 40, 50, 63	6, 10, 13, 16, 20, 25, 32, 40, 50, 63	6, 10, 13, 16, 20, 25, 32, 40
Rated voltage (VAC)	230/400	400	400	400	230
Breaking capacity (kA) sym. (IEC 60898)	6				

Operating Characteristics

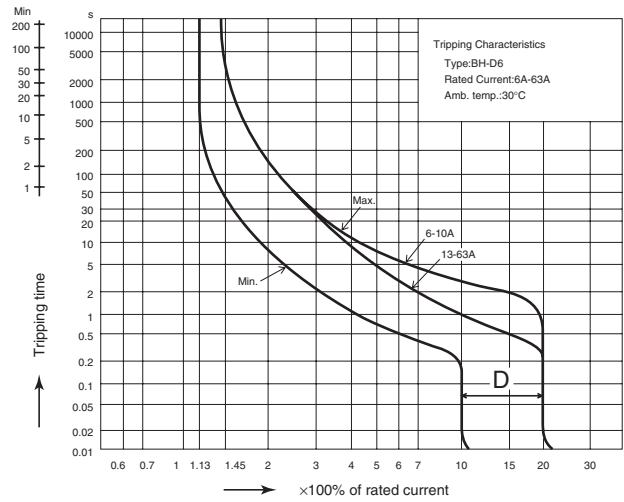
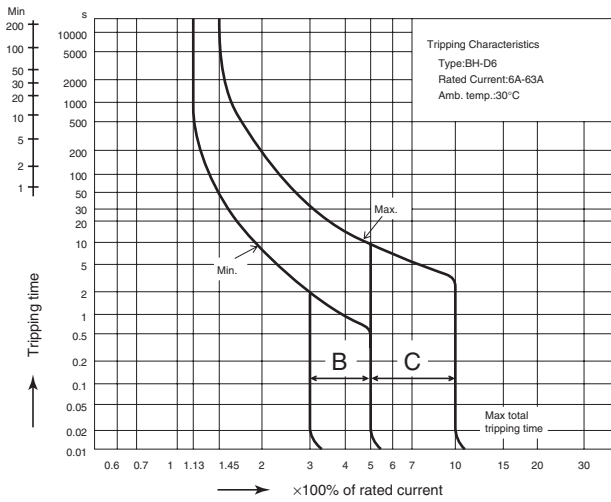

Ambient Compensating Curve

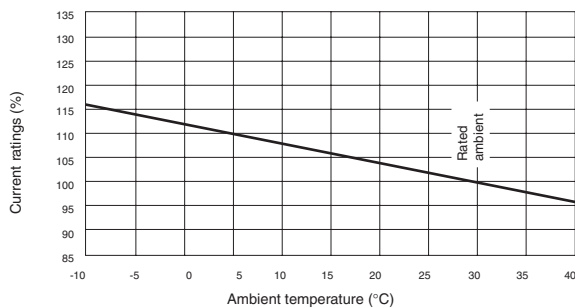

Outside Dimension Diagram

•BH-D6

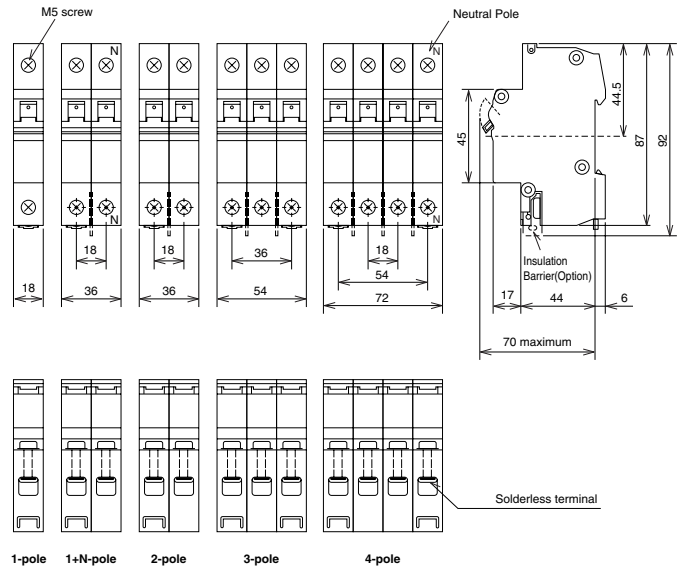

6. Characteristics and Dimensions

DIN Series

BH-DN



Type BH-DN

MCB	BH-DN (IEC 60898)
Number of poles	2 (1+N)
Rated current (A) at ambient temperature 30°C	6, 10, 16, 20
Rated voltage (VAC)	230
Breaking capacity (kA) sym. (IEC 60898)	4.5

Operating Characteristics

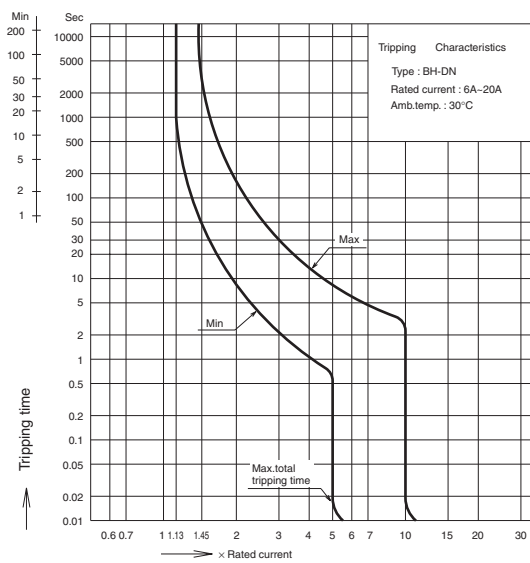

Outside Dimension Diagram

•BH-DN

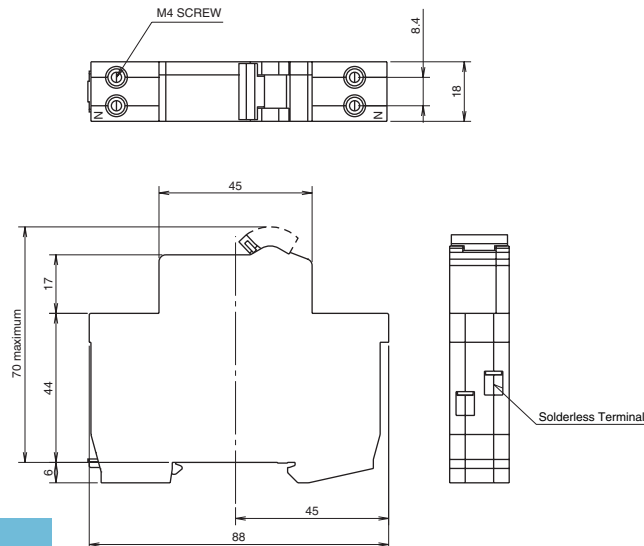

BV-D



Type BV-D

RCCB	BV-D (IEC 61008)	
	2 (1+N)	4 (3+N)
Number of poles	2 (1+N)	4 (3+N)
Rated current (A) at ambient temperature 30°C	25, 40, 63	
Rated voltage (VAC)	230	230/400
Rated current sensitivity I Δ n (mA)	30, 300	
Max. operating time (sec) at 5I Δ	0.04	
Pulsating current sensitivity	Type AC	
Rated conditional short-circuit (kA)	6	

Operating Characteristics

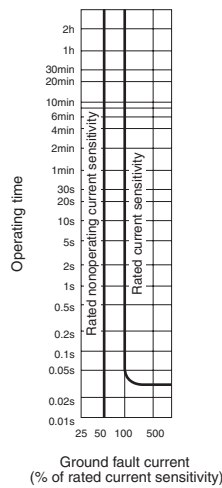

Outside Dimension Diagram

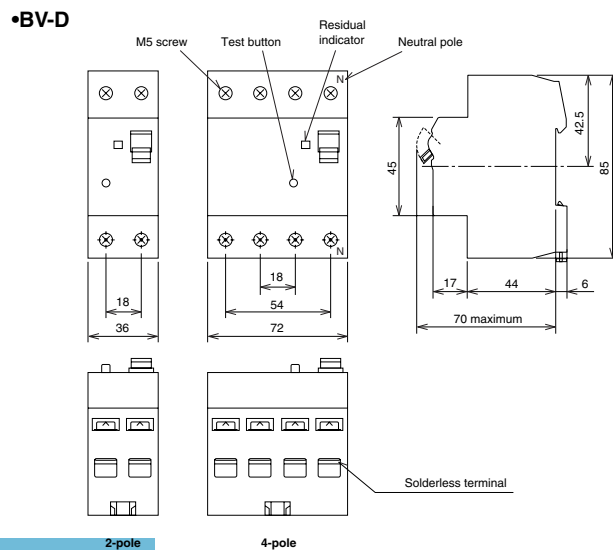

6. Characteristics and Dimensions

DIN Series

BV-DN



Type BV-DN

RCBO	BV-DN (IEC 61009)
Number of poles	2 (1+N)
Rated current (A) at ambient temperature 30°C	6, 10, 16, 20, 25, 32
Rated voltage (VAC)	230
Rated current sensitivity I _{Δn} (mA)	30, 100, 300
Max. operating time (sec) at 5I _{Δn}	0.04
Pulsating current sensitivity	Type AC
Breaking capacity (kA) sym (IEC 61009)	4.5

Operating Characteristics

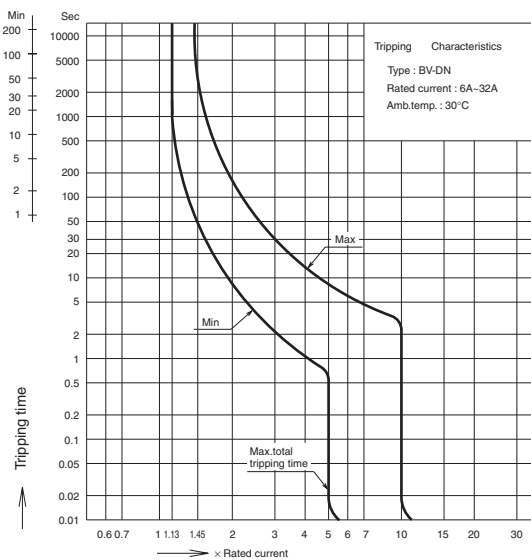

Leakage Tripping characteristics

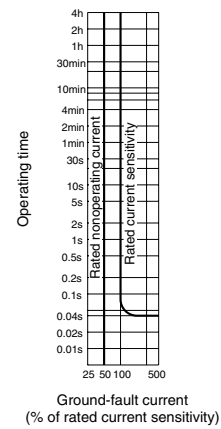

Outside Dimension Diagram

•BV-DN

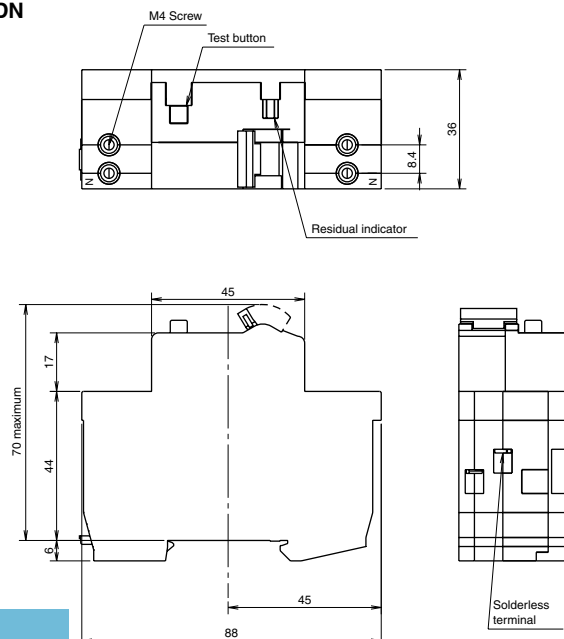

KB-D



Type KB-D

Isolating switch	KB-D (IEC 60947-3)			
Number of poles	1	2	3	4 (3+N)
Utilization category	AC22A class			
Rated current (A) at ambient temperature 30°C	32, 63, 80			
Rated voltage (VAC)	230	400		
Shot time withstand current (A)	20 × I _n , 1s			
Shot-circuit making capacity (A)	20 × I _n			

Outside Dimension Diagram

•KB-D

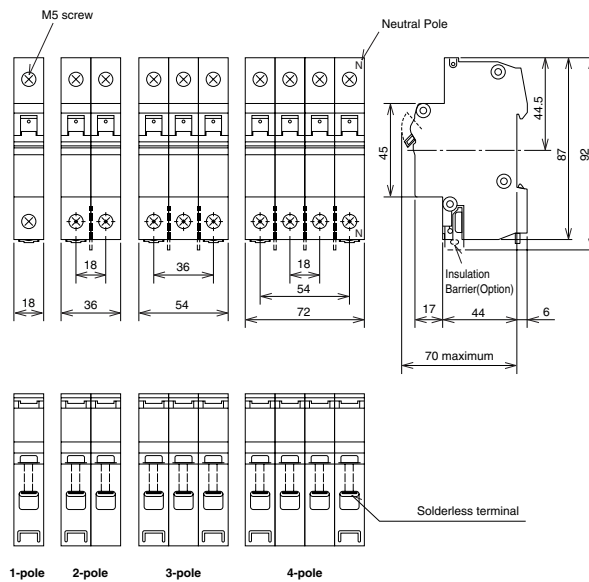

6. Characteristics and Dimensions

Circuit Protectors

CP30-BA



Type CP30-BA

Frame (A)		30			
Type		CP30-BA			
Number of poles		1	2	3	
Rated impulse withstand voltage Uimp (kV)		2.5			
Rated current (A)		0.1, 0.25, 0.3, 0.5, 1, 2, 3, 5, 7, 10, 15, 20, 30			
Rated short-circuit capacity (kA)	UL 1077 CSA C22.2 No.235	Rated voltage (V)	AC (V)		250
			DC (V)	65	125
		AC	2.5kA at 250V		
		DC	2.5kA at 65V	2.5kA at 125V	—
	IEC 60934 EN 60934 GB 17701 JIS C 4610	Rated insulation voltage Ui (V)	250		
		AC	2.5kA at 230V		
EN 60947-2 IEC 60947-2 JIS C 8201-2-1 Annl (lcu/lcs)	Rated insulation voltage Ui (V)	250			
	AC	2.5/2.5kA at 230V			
	DC	2.5/2.5kA at 60V	2.5/2.5kA at 120V	—	
AC-DC common use		●			
Operating characteristics		Instantaneous type (I) Medium type (M),(MD) Slow type (S),(SD) Fast type (F)			
Mode of tripping		Instantaneous type (I): magnetic only Other type (M, MD, S, SD, F):hydraulic-magnetic			

Operating Characteristics

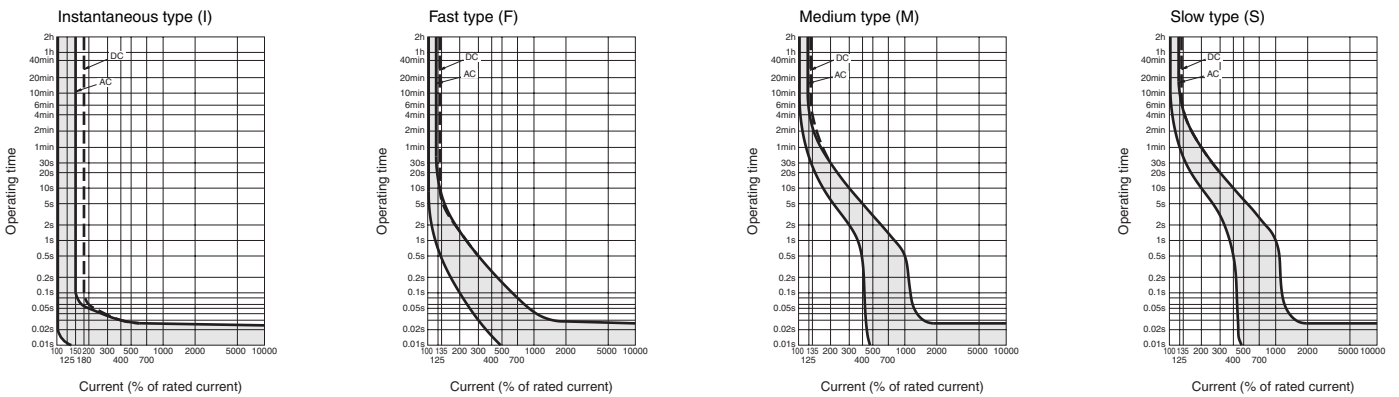

Outside Dimension Diagram

CP30-BA

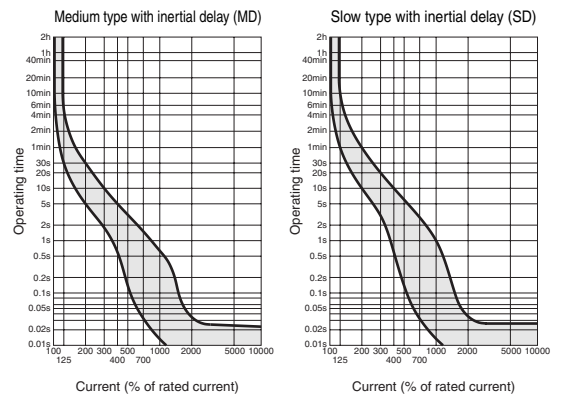
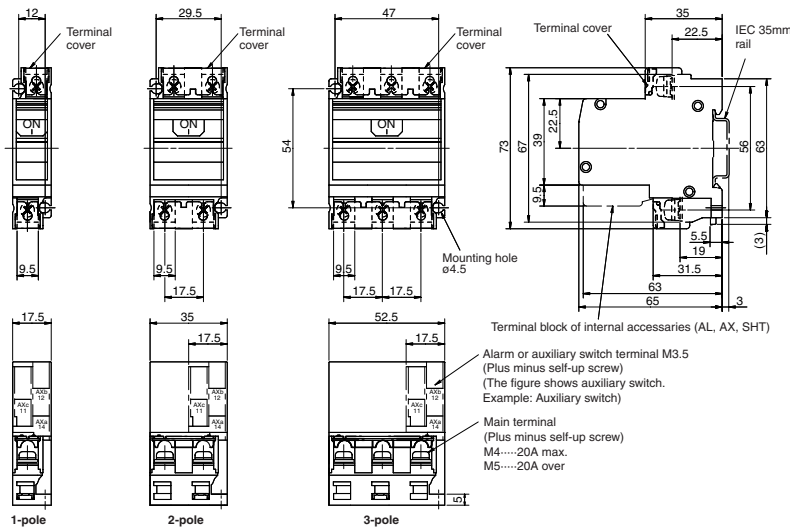

Temperature Characteristics

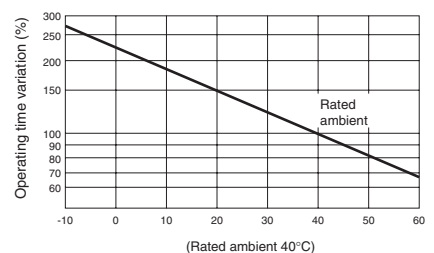

CP-S



Type CP-S

Frame (A)		30			
Type		CP-S			
Number of poles		1	2	3	
Rated impulse withstand voltage U_{imp} (kV)		2.5			
Rated current (A)		0.05, 0.1, 0.25, 0.3, 0.5, 0.75 1, 2, 2.5, 3, 5, 7, 7.5, 10, 15, 20, 25, 30			
Rated short-circuit capacity (kA)	UL 1077	Rated voltage (V)	AC (V)	250	—
			DC (V)	65	—
		AC	1.5kA at 250V	—	
	DC	1kA at 65V	—		
	IEC 60934 EN 60934 (Icn)	Rated insulation voltage U_i (V)		250	
		AC	1.5kA at 230V, 2.5kA at 120V		
DC		1kA at 60V	1kA at 120V (1kA at 60V)	1kA at 60V	
JIS C 4610 (Icn)	Rated insulation voltage U_i (V)		250		
	AC	1.5kA at 250V, 2.5kA at 125V			
	DC	1kA at 65V	1kA at 125V (1kA at 65V)	1kA at 65V	
AC-DC common use		—			
Operating characteristics		Instantaneous type (I) Medium type (M),(MD) Slow type (S),(SD) Fast type (F),(FD)			
Mode of tripping		Instantaneous type (I): magnetic only Other type (M, MD, S, SD, F, FD):hydraulic-magnetic			

Operating Characteristics

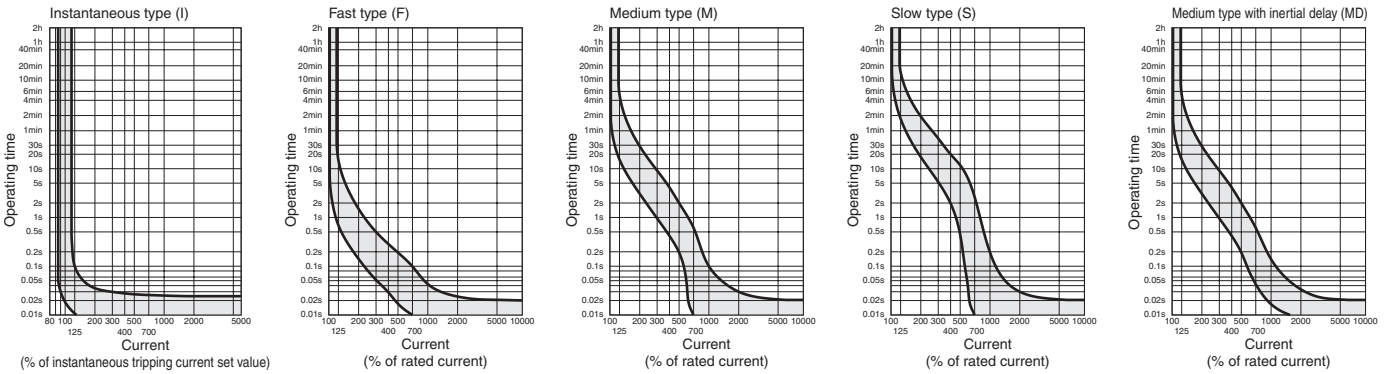

Outside Dimension Diagram

CP-S

Series <With auxiliary switch (AX), With series alarm switch (AL)>
Switch <With switch type auxiliary switch (AX)>

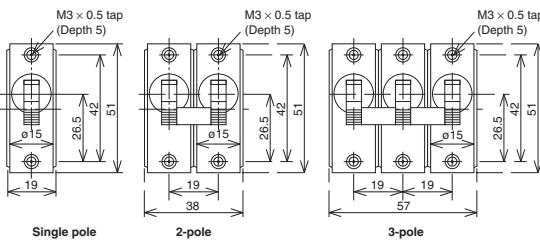
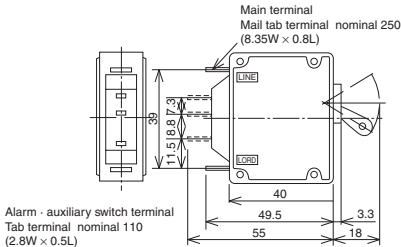

Temperature Characteristics

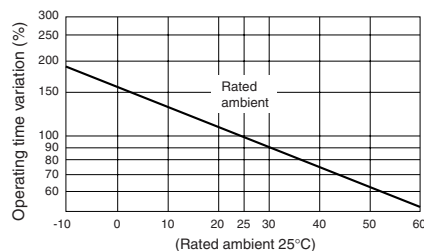

7. Ordering Information

Molded-Case Circuit Breakers

Type name	NF		C	Economy type
NF250-SW			S	Standard type
			H	High-performance type
			U	Ultra current-limiting type
	MB		Motor braker	
	DSN		DSN-Type switches	
Number of poles	NF•DSN		2P, 3P, 4P	
3P	MB		3P	
Rated current	200A			
	Even for adjustable rated current models, the working current should be specified.			
Rated voltage	Specify DC voltage when for use in DC circuit			
Standard	Specify the applicable marine standards *“CE” is standard.			
Connection method	F	Front connection		
	SL	Solderless (box) terminal		
B	B	Rear connection		
	PM	Pulg-in		
Built-in Accessories	PAL	Pre-alarm (contact output)		
PAL	OAL	Overcurrent alarm		
Internal accessories	AL	Alarm switch		
	AX	Auxiliary switch		
AL, SHT (AC110V)	SHT	Shunt trip (Specify rated coil voltage.)		
	UVT	Under voltage trip (Specify rated coil voltage.)		
External accessories	SLT	Lead-wire terminal block		
	INT	Internal terminal type		
Special Purpose Breakers	MD	Electrical operation device		
	F•S•V	Operating handle		
	S•I•W	Enclosure box		
	MI	Mechanical interlock		
	TC	Terminal cover (TC-L, TC-S, TTC, BTC)		
	LC•HL	Handle lock device		
	HL-S			
	CH	Card holder		
Quantity	10			
	Mag Only	Mag Only (Specify AC or DC and rated current)		
	DC400V	DC-use (Specify DC 400V, 440V, 500V, 550V, 600V)		
	400HZ	400HZ-use		
	Low-Inst.	Low-Inst. (Specify AC or DC and Inst. %)		

Earth-Leakage Circuit Breakers

Type name	NV		C	Economy type
NV250-SW			S	Standard type
			H	High-performance type
			U	Ultra current-limiting type
Number of poles	2P	NV	1ø2W	
3P	3P	NV	1ø2W 1ø3W 3ø3W	
	4P	NV	3ø4W	
Rated current	200A			
	Even for adjustable rated current models, the working current should be specified.			
Rated voltage	AC			
	AC			
	100-440V			
	200-440V			
Rated sensitivity current	100•200•500mA			
	30mA			
	100•200•500mA			
Standard	Specify “CE”, if necessary			
Connection method	F	Front connection		
	SL	Solderless (box) terminal		
B	B	Rear connection		
	PM	Pulg-in		
Type of residual current protection	Blank	High-speed type		
	Specify	Time-delay type		
Built-in Accessories	MG	Insulation switch		
MG	EAL	Earth-leakage circuit alarm switch		
	TBM	Test button module		
	PAL	Pre-alarm module		
Internal accessories	AL	Alarm switch		
	AX	Auxiliary switch		
AX, SLT, TBM	UVT	Under voltage trip (Specify rated coil voltage)		
	SLT	Lead-wire terminal block		
External accessories	MD	Electrical operation device		
	F•S•V	Operating handle		
	S•I•W	Enclosure box		
	MI	Mechanical interlock		
	TC	Terminal cover (TC-L, TC-S, TTC, BTC)		
	LC•HL	Handle lock device		
	HL-S			
	CH	Card holder		
Quantity	10			

8. Melshort 2

A Smarter, Easier Way to Select Breakers

This software program ensures the easy selection of low-voltage circuit breakers according to the required rated breaking capacity and related equipment.

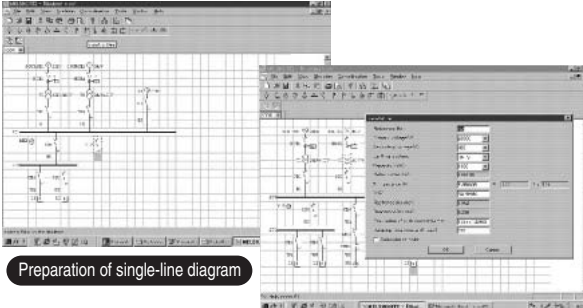
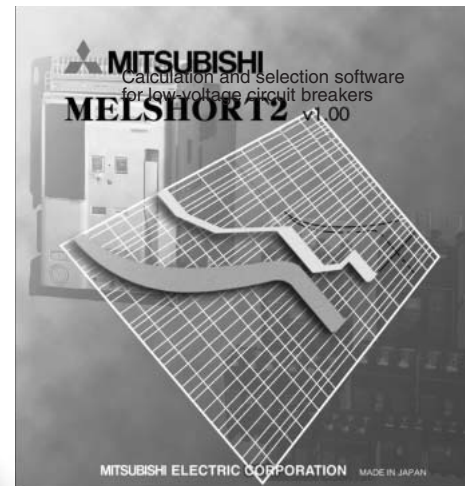

Preparation of single-line diagram

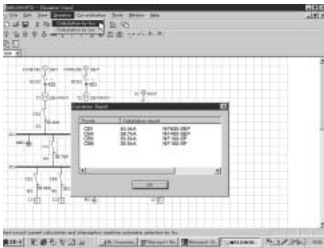

Short-circuit current calculation

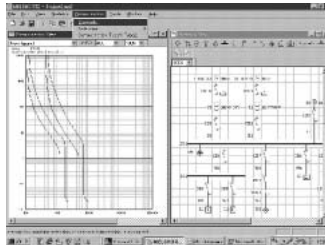

Examination of cascade interruption combination

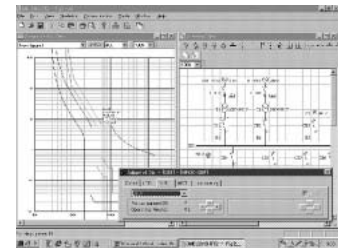

Coordination between high-voltage protection equipments

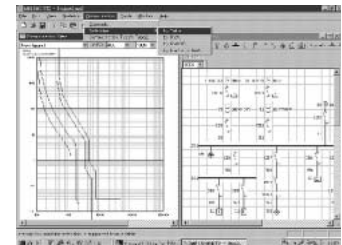

Examination of selective interruption

Advantages

●Contents

The program's menu allows not only short-circuit current calculations, but also the examination of various protection coordination.

- Preparation of single-line connection diagrams.
- Short-circuit calculations.
- Automatic selection of breaker type.
- Selection of breaker type for cascade interruption combination.
- Selection of breaker type for selective interruption combination.
- Examination of coordination between high-voltage protection equipment.
- Protection coordination with motor start current.

■Products Menu

Low-voltage circuit breakers:
MCCBs, ELCBs, ACBs, MCBs, Contactors,
Thermal relays, High-voltage OCRs

●Selection Efficiency Improved

Simple, accurate and fast operation is ensured as a result of being able to examine the coordination between various protection systems, and being able to select breakers interactively on the screen.

●Software Updates

Users can download the latest software updates by accessing Mitsubishi's LVS home page.

<http://www.fukuyama.melco.co.jp/lvs>

■Computer Requirements

Operating system: Windows 95/98/NT4.0/2000/XP
CPU: 166 MHz or faster
RAM memory size: min 32 MB
Free hard disk capacity: min 50 MB
Display resolution: min 640 × 480 dots
CD-ROM Drive: 2x or higher

9. LOW-VOLTAGE SWITCHGEAR TECHNICAL

Changes for the Better

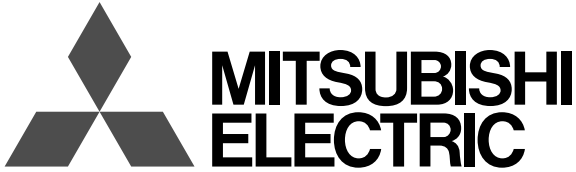

www.MitsubishiElectric.co.jp/haisei/lvs/

Introducing a New Look...

Low-voltage Products Website Renewed

— Easier to Navigate, More Information Available —

Whether you are looking for information on high-performance power distribution/protection systems and energy-saving support equipment or simply interested in one of our many low-voltage power control products, we've made things easier for you to find. The website is now organized to provide enhanced usability for customers, and the latest information on our low-voltage products and systems. Please be sure to visit, check out our new look, and bookmark the site for future reference.



Four Key Features

1 Product Information

Based on past customer requests, we've increased the content to include a full product line-up, product specifications and relevant CAD data. The Products pages are divided into two categories:

Low-voltage Circuit Breakers

World Super (WS) Series Next-generation Circuit Breakers (ACBs, MCCBs, ELCBs and MCBs)

Energy Measuring Devices

New S Series Multi-measuring Instruments, EcoMonitorPro Energy Measuring Unit

2 Downloads

The latest catalogs, information on certifications acquired, handling and maintenance information, and technical notes can all be downloaded free of charge. We've organized the information for maximum customer convenience, and will be updating the contents periodically.

3 News

Check here for the latest, up-to-date news on Mitsubishi Electric products such as new product releases and changes in specifications.

4 Support

Our interest is to serve you! Please contact us whenever you have a question or are in need of support. We'll reply at the earliest possible time. Committed to supporting our customers' businesses, we also provide information through Mitsubishi Electric's global network.

“ **Empowering
Industries** ”

INFORMATION SERVICE VIA THE INTERNET

Product Line-up

Mitsubishi Electric manufactures intelligent high-performance low-voltage products that are renowned for their high reliability. Each product page provides product details and other information required to help you make the right decision, as well as links to other pages of related interest, such as downloadable catalogs and product certifications.

Low-voltage Products Circuit Breakers

- Air Circuit Breakers (ACB)
- Molded-case Circuit Breakers (MCCB)
- Earth-leakage Circuit Breakers (ELCB)
- Miniature Circuit Breakers (MCB)
- Measuring Display Unit Breakers
- UL-listed Products
- Circuit Protectors
- Motor Protection Breakers



Energy Measuring Devices

- Multi-measuring Instrument
- Energy Measuring Unit



Downloads

Download useful product information in PDF format whenever you need it.

- Catalogs
- Approved certifications
- Handling and maintenance
- Technical notes



About Us

The outstanding technological expertise of the Fukuyama Works has led to its recognition as a leader in the field of power distribution control equipment. These pages provide various information on the works, including our history and manufacturing facilities.

Related Websites

Mitsubishi Electric offers a variety of FA products and systems. For further information, please visit the Mitsubishi Electric Global Website at:

Global.MitsubishiElectric.com

MEMO

Service network

Country / Region	Company	Address	Telephone
Australia	Mitsubishi Electric Australia Pty. Ltd.	348 Victoria Road, Rydalmere, N.S.W. 2116, Australia	+61-2-9684-7777
Chile	Rhona S.A.	Agua Santa 4211 P.O. Box 30-D Vina del Mar, Chile	+56-32-2-320-600
China	Mitsubishi Electric Automation (Shanghai) Ltd.	17/F., ChuangXing Financial Center, No.288 West Nanjing Road, Shanghai, 200003	+86-21-2322-3030
China	Mitsubishi Electric Automation (HongKong) Ltd.	10/F., Manulife Tower, 169 Electric Road, North Point, Hong Kong	+852-2887-8810
Colombia	Proelectrico Representaciones S.A.	Carrera 53 No 29C-73 - Medellin, Colombia	+57-4-235-30-38
Egypt	Cairo Electrical Group	9, Rostoum St. Garden City P.O. Box 165-11516 Maglis El-Shaab, Cairo - Egypt	+20-2-27961337
Europe	Mitsubishi Electric Europe B.V.	Gothaer Strasse 8, D-40880 Ratingen, Germany	+49-(0)2102-486-0
Indonesia	P. T. Sahabat Indonesia	P.O.Box 5045 Kawasan Industri Pergudangan, Jakarta, Indonesia	+62-(0)21-6610651-9
Korea	Mitsubishi Electric Automation Korea Co., Ltd	1480-6, Gayang-Dong, Gangseo-Gu, Seoul, Korea	+82-2-3660-9572
Laos	Societe Lao Import Co., Ltd.	43-47 Lane Xang Road P.O. BOX 2789 VT Vientiane Laos	+856-21-215043
Lebanon	Comptoir d'Electricite Generale-Liban	Cebaco Center - Block A Autostrade Dora, P.O. Box 11-2597 Beirut - Lebanon	+961-1-240445
Malaysia	Mitric Sdn Bhd	5 Jalan Pemberita U1/49, Temasya Industrial Park, Glenmarie 40150 Shah Alam, Selangor, Malaysia	+603-5569-3748
Myanmar	Peace Myanmar Electric Co.,Ltd.	NO137/139 Botataung Pagoda Road, Botataung Town Ship 11161, Yangon, Myanmar	+95-(0)1-202589
Nepal	Watt&Volt House	KHA 2-65, Volt House Dillibazar Post Box:2108, Kathmandu, Nepal	+977-1-4411330
Other Middle East Arab Countries & Cyprus	Comptoir d'Electricite Generale-International-S.A.L.	Cebaco Center - Block A Autostrade Dora P.O. Box 11-1314 Beirut - Lebanon	+961-1-240430
Pakistan	Prince Electric Co.	1&16 Brandreth Road, Lahore-54000, Pakistan	+92-(0)42-7654342
Philippines	Edison Electric Integrated, Inc.	24th Fl. Galleria Corporate Center, Edsa Cr. Ortigas Ave., Quezon City Metro Manila, Philippines	+63-(0)2-634-8691
Saudi Arabia	Center of Electrical Goods	Al-Shuwayer St. Side way of Salahuddin Al-Ayoubi St. P.O. Box 15955 Riyadh 11454 - Saudi Arabia	+966-1-4770149
South Africa	CBI-electric: low voltage	Private Bag 2016, Isando, 1600, South Africa	+27-(0)11-9282000
Taiwan	Setsuyo Enterprise Co., Ltd	6th Fl., No.105, Wu Kung 3rd, Wu-Ku Hsiang, Taipei, Taiwan, R.O.C.	+886-(0)2-2298-8889
Thailand	United Trading & Import Co., Ltd.	77/12 Bamrungmuang Road, Klong Mahanak, Pomprab Bangkok Thailand	+66-223-4220-3
Uruguay	Fierro Vignoli S.A.	Avda. Uruguay 1274, Montevideo, Uruguay	+598-2-902-0808
Venezuela	Adesco S.A.	Calle 7 La Urbina Edificio Los Robles Locales C y D Planta Baja, Caracas - Venezuela	+58-212-241-9952
Vietnam	CTY TNHH-TM SA GIANG	47-49 Hoang Sa, St., Dakao Ward, Dist 1, Ho Chi Minh City, Viet Nam	+84-8-9103633

Safety Tips : Be sure to read the instruction manual fully before using this product.

 **MITSUBISHI ELECTRIC CORPORATION**
FACTORY AUTOMATION SYSTEM: TOKYO BUILDING, 2-7-3 MARUNOUCHI, CHIYODA-KU, TOKYO 100-8310, JAPAN

المنارة للاستشارات